



STATION SQUARE STATION AREA PLAN

PORT AUTHORITY OF ALLEGHENY COUNTY
PLANNING AND EVALUATION DEPARTMENT

STATION SQUARE

STATION AREA PLAN

**PORT AUTHORITY OF ALLEGHENY COUNTY
PLANNING AND EVALUATION DEPARTMENT**

ACKNOWLEDGMENTS

About the Port Authority

Port Authority of Allegheny County (PAAC) provides public transportation throughout Pittsburgh and Allegheny County.

The Authority's 2,600 employees operate, maintain and support bus, light rail, incline and paratransit services for approximately 200,000 daily riders.

Port Authority is governed by an 11-member board – unpaid volunteers who are appointed by the Allegheny County Executive, leaders from both parties in the Pennsylvania House of Representatives and Senate, and the Governor of Pennsylvania. The board and its committees hold regularly scheduled public meetings.

Port Authority's budget is funded by fare and advertising revenue, along with money from county, state, and federal sources. The Authority's finances and operations are audited on a regular basis, both internally and by external agencies.

Port Authority began serving the community in March 1964. In early 2015, the Port Authority began investing in a transit-oriented development program. This document is the result of investment to date, overseen by TOD staff and an interdisciplinary working group focused on TOD.

Participants

Port Authority of Allegheny County would like to thank agency partners for supporting the station area planning project at Station Square Station, and all those who participated by dedicating their time and expertise.

This document was stewarded internally by Port Authority's TOD advisory committee, an inter-departmental body established to support the Station Improvement Program and other TOD activities. Current Port Authority Divisions and Departments represented on the committee include: Facilities & Rail Maintenance, Grants & Capital Programs, Legal & Consulting Services, Planning & Evaluation, Road Operations, Service Development & ITS Technology, System Safety, and Technical Support & Capital Programs. This committee and development of station area planning are managed by Breen Masciotra, TOD Project Manager, and Andrea Elcock, Community Planning Coordinator.

This study was developed by the Port Authority of Allegheny County in collaboration with the Community Solutions Group of GAI Consultants, evolve environment::architecture, and Breen Associates. All maps and graphics were created by Community Solutions Group and evolveEA unless otherwise noted.

Station Square Station is the second plan to be produced by the Port Authority's Station Improvement Program which was initiated in 2016.

Port Authority

COMMUNITY SOLUTIONS GROUP



Published in March 2018.

CONTENTS

1	Introduction	1
	What is Station Area Planning?	2
	How to Use this Plan	3
	Planning Process	4
	Analysis at Three Scales	5
	Station Square: A Downtown Station	6
	Station Square: Urban Context	8
	Station Square: Transit Context	10
	Station Square: Historical Context	12
	Stakeholders at Station Square	14
2	Station Area Plan	17
	2.1 Neighborhood Context	18
	2.2 Station Access	22
	2.3 Station Analysis	32
3	Station Conceptual Design	37
	3.1 Transit Center Conceptual Design	39
	3.2 Incline Station	42
	3.3 LRT Station	50
4	Implementation Strategy	67
	4.1 Implementation	68
	4.2 Collaborate	70
	4.3 Design	72
	Appendices	75
	A.1 Transportation Planning	76
	A.2 Community Engagement Material	108

1.



INTRODUCTION

WHAT IS STATION AREA PLANNING?

Station area planning examines the challenges and opportunities for existing Port Authority fixed guideway stations within the context of three scales. For many communities, this process also serves as the first opportunity to engage in conversation with the Port Authority about issues related to station configuration, access, land use, and potential transit-oriented development (TOD) opportunities.

The Port Authority's Planning and Evaluation Department, supported by its consultant team - comprised of Community Solutions Group, evolve environment::architecture, and Brean Associates - outlined the following objectives for Station Square:

- Plan for cost effective station improvements that will increase ridership at the station, thereby increasing the revenue potential for the Port Authority. These kinds of facility-specific improvements could generate increased ridership, as well as attract new real estate investment.
- Improve connectivity, operations, and overall function at the station in order to encourage high quality TOD on land adjacent to the station.
- Engage all of the relevant stakeholders to ensure that TOD opportunities are community-supported and complimentary to other planned projects. This will facilitate implementation of initiatives supportive of TOD (e.g. TOD-friendly zoning, strategic purchase of land, recommended roadway improvements).



Members of the public met with the project team for workshops in June 2017 to discuss challenges and opportunities in the Station Square Area. This image is from the morning workshop.

HOW TO USE THIS PLAN

This document is meant to provide the entire community of Station Square area and transit-oriented development stakeholders - riders, residents, transit agencies, local governments, regional planners, community groups, developers, and others - with a common understanding of the existing conditions and opportunities for Station Square.

It should be used to:



Transit-Oriented Development: Encourage development that integrates and expands transit use at Station Square.

Per the Port Authority's 2016 Transit-Oriented Development Guidelines, TOD allows people to integrate transit use into their lives by creating dense, mixed-use places where they can live, work, shop, and play. Though Port Authority's land holdings at Station Square do not have development potential, this document provides guidance for Port Authority's role as a collaborator with adjacent property owners.



Station Access: Make it easy for people to get there.

Getting to and from the station should be an enjoyable experience for all transit users. Three Port Authority modes interface in this transit center: buses, light rail, and inclined railway. Station access improvements should make using all modes easy to understand and should enhance the transfer experience. This document provides recommendations for the station area, including improvements to sidewalks, crosswalks, intersections, and public areas.

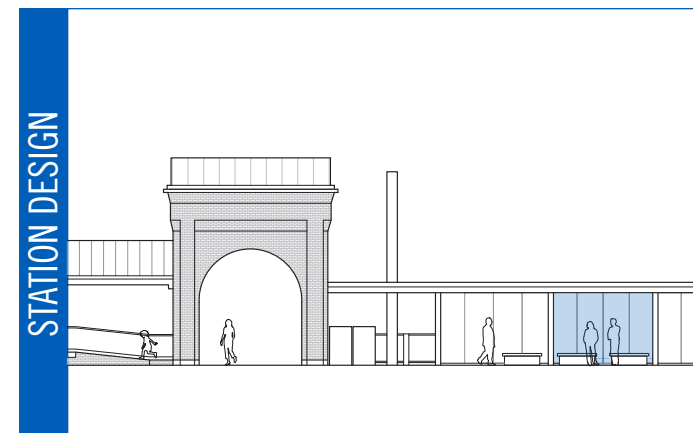

Station Design: Create a welcoming, unified station.

The design of the station influences ease of use, operational efficiency, and how users perceive its quality. Strategic investments should be made to update the station's appearance and amenities so that it is more recognizable as a high-value transit amenity. This document provides conceptual design recommendations for the light rail station and the incline station as well as the landscape in between.

PLANNING PROCESS

The consultant team, working under the guidance of Port Authority's Planning and Evaluation Department, performed this study in four phases: Review and Analysis, Public Engagement, Station Area Plan, and Implementation Strategy.

Review and Analysis gave the team the background information to understand existing challenges and opportunities. This phase formed the basis for identifying potential infrastructure strategies that could be valuable for the Port Authority and the communities surrounding Station Square.

Public Engagement opened a channel of dialogue between the public, the Port Authority, and the consultant team to discuss existing conditions and desires. The first set of meetings were working sessions that allowed community members to collaborate in analysis and design in order to identify challenges they face in using the station and to prioritize potential interventions. The second set were presentations and discussions that allowed community members to learn about and critique proposed strategies for addressing their concerns and other challenges identified in the station area.

In the station area plan, the team used input from the community, input from Port Authority staff, and urban design best practices to propose improvements to station design and station access. Plan development was also informed by issues including safety, property ownership, cost, operational efficiency, and alignment with other initiatives. After initial concepts were created, they were vetted by the community at the second set of public meetings.

Implementation Strategy focused on the Port Authority's role in moving proposed projects forward. For any given station area project, the Port Authority may be tasked with designing station area improvements or acting as a supporter for improvements nearby.

Review and Analysis

- Reviewed relevant plans and studies to understand previously documented challenges and opportunities
- Reviewed historic maps and photos to understand how existing infrastructure and development patterns came to be
- Reviewed Port Authority station user surveys.
- Engaged with potential project partners and agencies to understand current projects in motion
- Performed a preliminary survey and a site walk

Public Engagement #1

- Presented initial findings at an interactive public meeting
- In three rotating discussion table groups, documented ideas, concerns, and questions about the Station Square area, Station Square itself, and potential development near the station
- After further concept development, met with the public again to report on project progress and to gather additional ideas, listen to concerns, and answer questions

Station Area Plan

- Developed plans for improvements to Station Square Station, the Monongahela Incline lower station, and nearby bus stops
- Developed plans for improvements to public realm infrastructure on and near Port Authority property

Public Engagement #2

Implementation Strategy

- Reviewed conceptual alternatives and institutional capacity to develop a strategy for project implementation

ANALYSIS AT THREE SCALES

This project was predicated upon the understanding that major public transit stations are important social and economic anchors for the communities they serve. To understand how Station Square is integrated within its community and the broader region, we considered issues at three scales:



STATION AREA

At the station area scale, we considered:

- Physical condition, assets and liabilities, environmental resources
- Customer use patterns and ridership
- Station connectivity and safety for pedestrians accessing the station as well as for multimodal transfers between Port Authority services
- Station area efficiency for day-to-day operations and major event operations

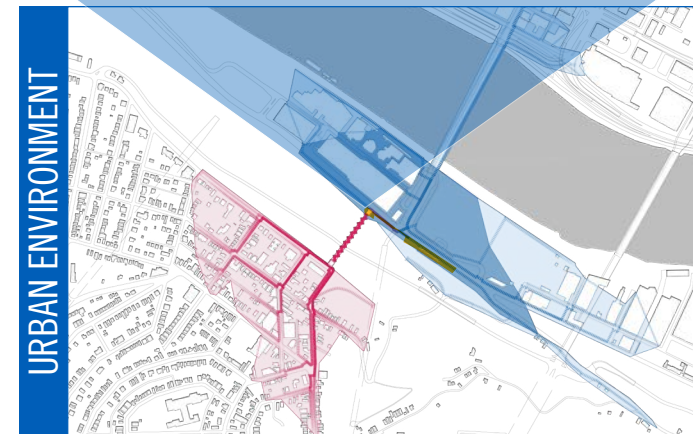

URBAN ENVIRONMENT

At the urban environment scale, we considered:

- Key transformations in the surrounding area that could be supportive of transit-oriented development
- Regulatory context and guiding documents
- Physical condition of infrastructure
- Economic trends in the adjacent area
- Cultural context with regards to community identity, place-making, and public art
- Community use patterns and perceptions
- Environmental context such as stormwater conveyance and ecological contiguity

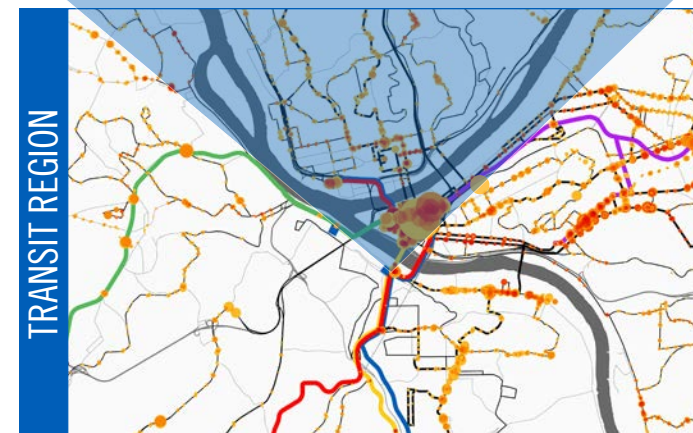

TRANSIT REGION

At the regional scale, we considered:

- Improving connectivity to other major nodes and the complimentary or competitive uses at those nodes
- Regional economic forces that affect the attractiveness and viability of this node
- Timing of station area initiatives in relation to other planned Port Authority projects and planned partner projects

STATION SQUARE: A DOWNTOWN STATION

The Port Authority of Allegheny County's Transit-Oriented Development Guidelines evaluated all 76 fixed guideway stations in its system. From this study, six TOD types were described and guidelines given for each. Station Square Station, located in an area with a high-density of jobs, was classified as a Downtown station.

Downtown stations are located in or on the perimeter of Downtown Pittsburgh's urban core. Serving as the largest employment center in the region, the area experiences the highest density of ridership in Port Authority's system. The stations in this category consist of three central stations, four stations on the immediate perimeter of central Downtown, and two stations across the river from central Downtown and adjacent to major North Shore attractions: PNC Park, Heinz Field, and Rivers Casino.

Automobile parking at Downtown stations should not exist because they are the end destination for a large volume of riders, transit is readily available, development opportunities are limited, and there is a density of uses and attractions nearby. High levels of transit service are provided to these stations throughout the work day and during special events, easing the challenges of limited parking and road congestion.

Page 18, PAAC TOD Guidelines, 2016



An aerial view of Station Square showing Mount Washington in the foreground, Station Square, and Downtown in the background. Source: Google Earth

Downtown Multimodal Highlights

- Enhance pedestrian access to development
- Park and Ride not appropriate
- Limit single occupancy vehicle parking
- Provide infrastructure for a high variety of modes (e.g. bike lanes, crosswalks, bus lanes, bike parking, etc.)

Downtown Walkability Highlights

- Connectivity likely strong due to existing street network
- Maintain and create public space
- Infrastructure should support high pedestrian use (e.g., wide sidewalks)

Downtown Development Highlights

- High floor area ratio (FAR)
- 3-60 stories
- 80-100% lot coverage
- Multifamily
- Building design should support and encourage street-level activity

Downtown Keys to Success

- Attract a 24/7 mix of uses
- Stress multimodal options
- Avoid surface parking and utilize structured parking for district-serving purposes only

Downtown Comparable Station Areas

- Gateway Station (Light Rail, Red and Blue)
- North Side Station (Light Rail, Red and Blue)
- Penn Station (East Busway, P1)

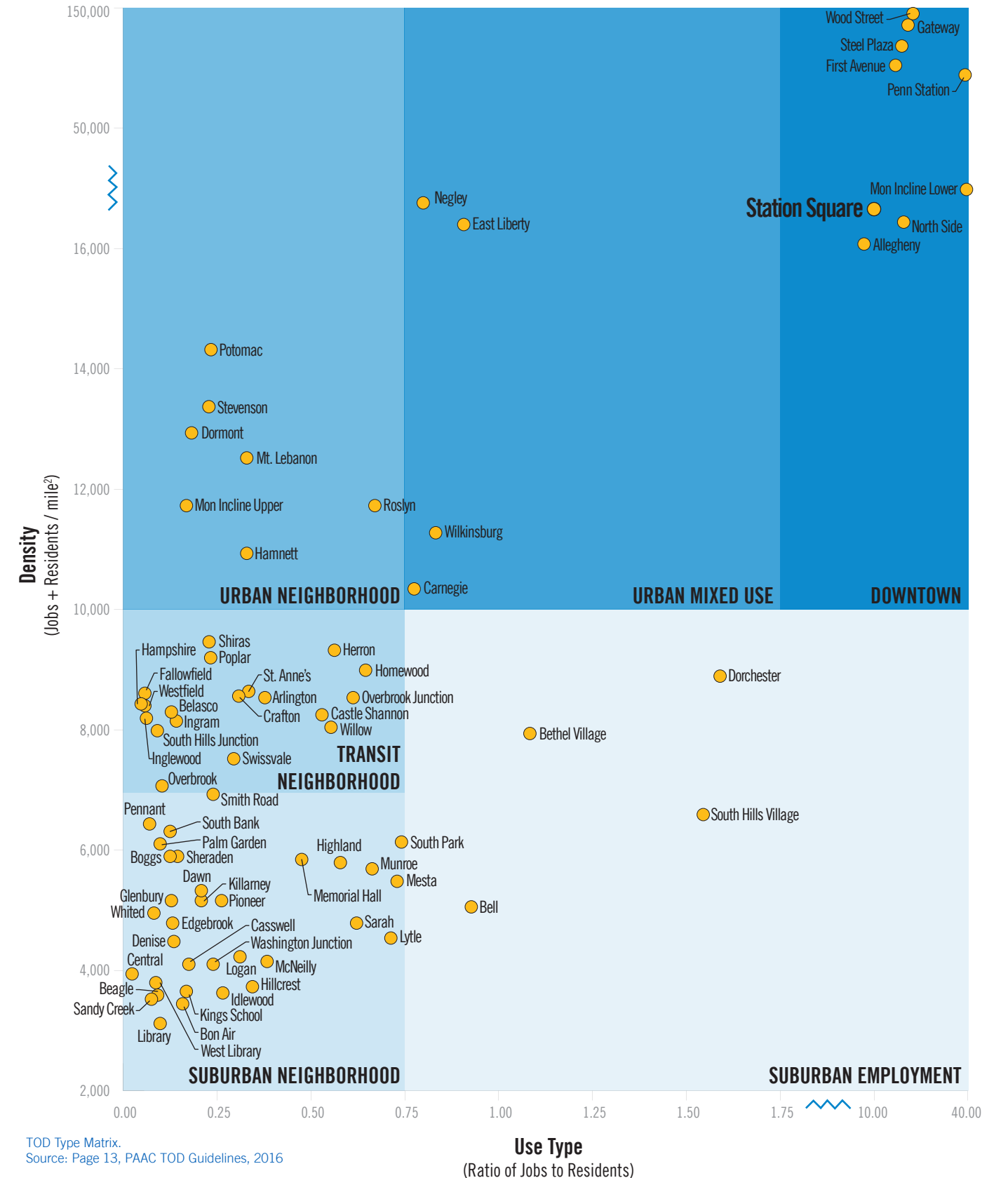

TOD Type Matrix. Source: Page 13, PAAC TOD Guidelines, 2016

STATION SQUARE: URBAN CONTEXT

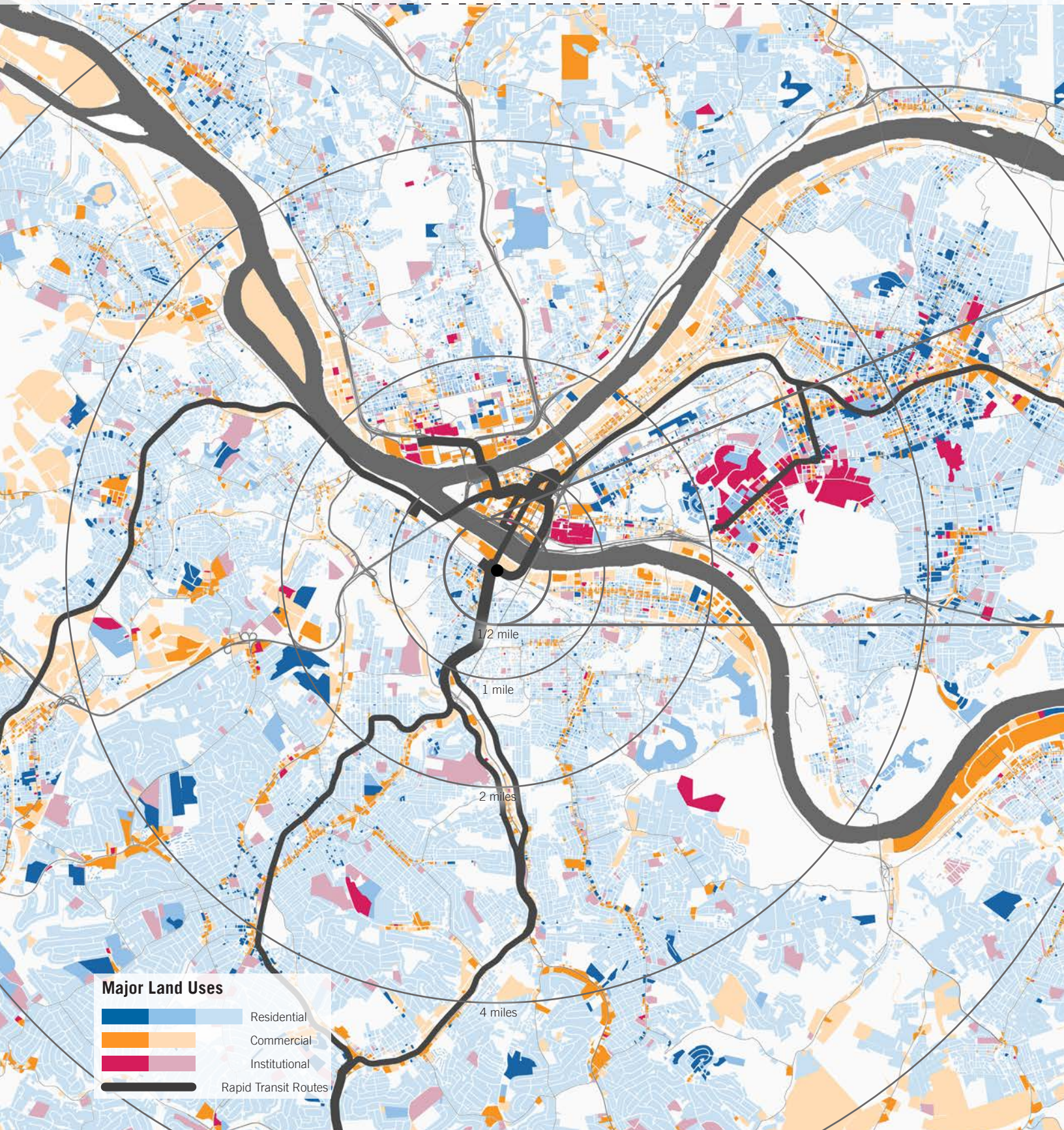

STATION AREA LAND USE

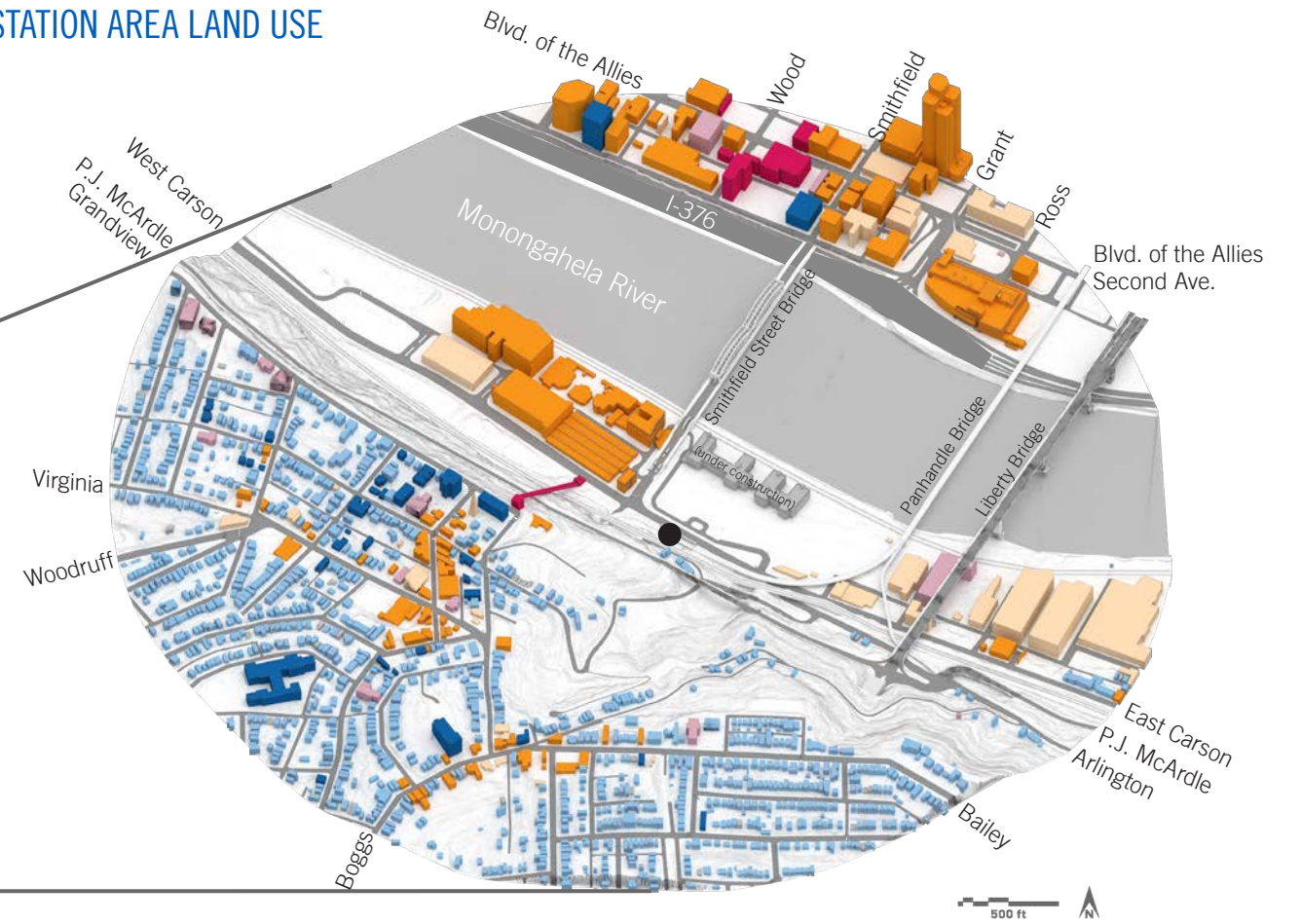

The Station Square transit center is tucked in between the steep hillside of Mount Washington and the Monongahela River. It is well connected to Downtown Pittsburgh for pedestrians, transit users, and car users via the Smithfield Street Bridge and its mix of commercial, retail, and entertainment spaces allow it to function as an extension of Downtown across the river. At the western end of Station Square is a soccer stadium and conference hotel with both structured and surface parking. At the center is a mix of large commercial offices over restaurants and retail. At the eastern end is surface parking with plans to develop mixed-use residential buildings and additional office buildings.

The Station Square transit center is also well connected to the Mount Washington community via the Monongahela Incline. Mount Washington is primarily a single-family residential community with a neighborhood commercial district along Shiloh Street that serves immediate need. Grandview Avenue is home to higher density residential buildings that take advantage of scenic views.

Traveling to Downtown:

- Using Smithfield Street at Sixth Avenue as a reference point.
- 16 minutes by foot
- 5 minutes by bicycle
- 8 minutes by bus (48, 51)
- 7 minutes by light rail transit (LRT Blue, LRT Red)
- 6 minutes by car

Traveling to Oakland:

- Using Forbes Avenue at S. Bouquet Street as a reference point.
- 66 minutes by foot
- 20 minutes by bicycle
- 22 minutes by bus (48, 51; then 61 ABCD, 67, 69)
- 8 minutes by car

STATION SQUARE: TRANSIT CONTEXT

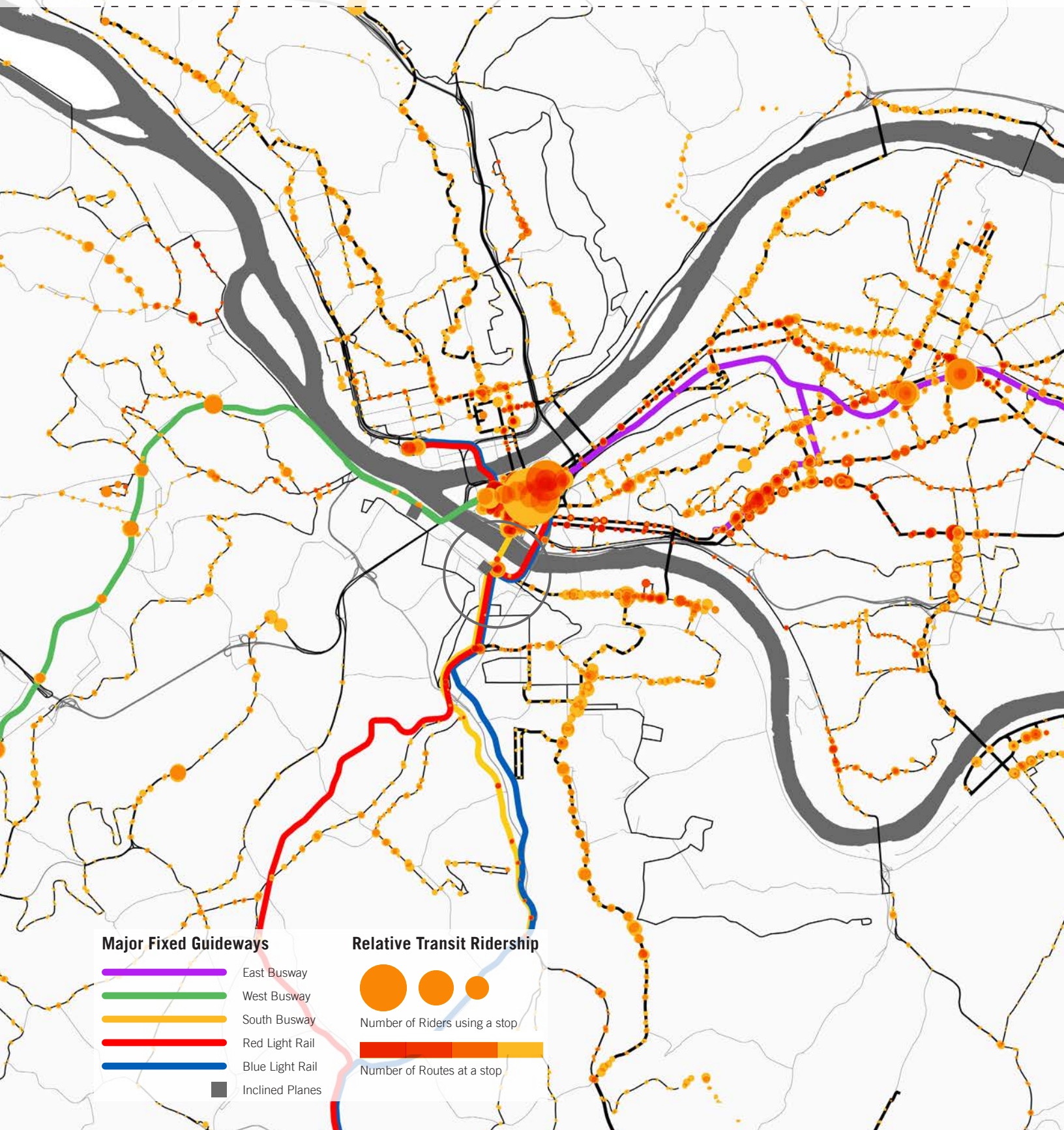

STATION AREA WALKABILITY

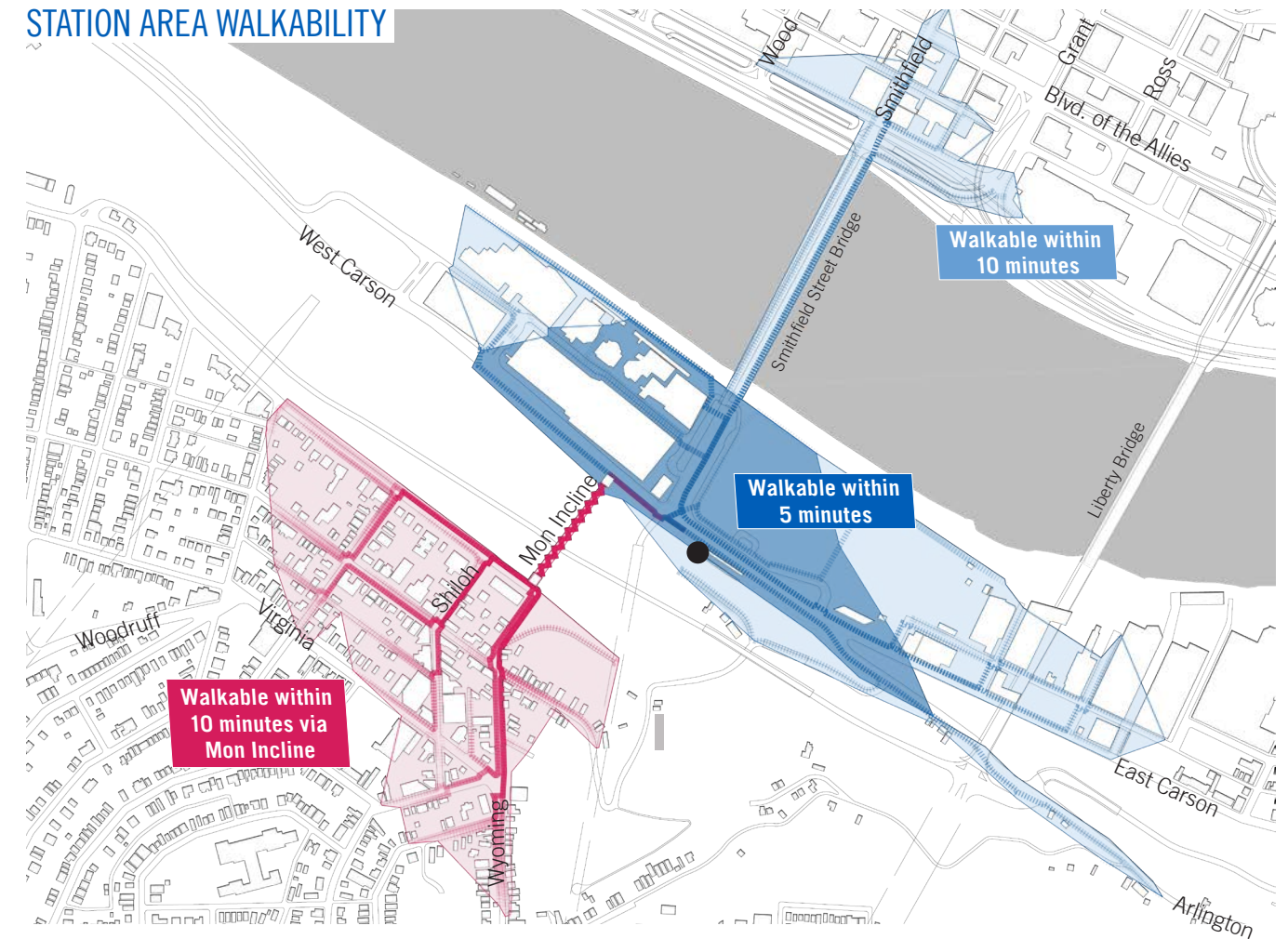

Transit routes serving the Station Square area:

BLUE LINE LIGHT RAIL

Library via Overbrook
South Hills Village via Overbrook

RED LINE LIGHT RAIL

Castle Shannon via Beechview
South Hills Village via Beechview

EXPRESS ROUTES USING SOUTH BUSWAY

Y1 Large Flyer
Y45 Baldwin Manor Flyer
Y46 Elizabeth Flyer
Y47 Curry Flyer
Y49 Prospect Flyer

MONONGAHELA INCLINE

ON-STREET BUS ROUTES

via Smithfield Street Bridge:

39 Brookline
40 Mount Washington
41 Bower Hill
43 Bailey
44 Knoxville
48 Arlington
51 Carrick

via Boulevard of the Allies:

52L Homeville Limited
53L Homestead Park Limited
56 Lincoln Place
57 Hazelwood
58 Greenfield
65 Squirrel Hill
67 Monroeville
69 Trafford

STATION SQUARE: HISTORICAL CONTEXT

Today's urban fabric is woven with relics of the past. The widths of the streets, the sizes of the homes, the structures of former medium-scale warehouses, and the parking lots in between are all elements of the built environment facing planners and developers. By understanding how and why these relics came to be, the next generation may better resolve the relationships between infrastructure, land use, and the people who make this area a vibrant community.

The station area was originally developed with coal mines, glass factories, and iron foundries. From the late 1800s to the early 1900s, rail yards and warehouses replaced most of the early developments in the area. Birmingham station was established for local riders along today's Norfolk Southern alignment. The Pittsburgh and Lake Erie Railroad established Station Square as its flagship terminal and its headquarters survives today as the Landmarks Building. The channelization of the Monongahela River allowed the shoreline to be pushed northward, creating space for the rail yard's expansion.

With the advent of the interstate highway system, the large freight rail yards throughout Pittsburgh were no longer needed. In Station Square, much of this space was converted to parking for the increased number of people commuting to work in Downtown by personal car from the new post-war suburbs.

During the 1980s and 1990s, Station Square was redeveloped as a destination mixed-use commercial, retail, and entertainment district. Former railroad warehouses and buildings were converted to new uses including offices, restaurants, shops, music venues, and a conference center and hotel. Today, there are plans to add additional new development east of Smithfield Street that would include residential units and additional offices.

The Smithfield Street Bridge was constructed in 1883 and modified in 1891, 1911, and again in 1995. Up until 1985, street cars from the South Hills passed through the Mount Washington Transit Tunnel and connected to Downtown via the eastern side of the Smithfield Street Bridge. Streetcars from Arlington Avenue and Carson Street also used the Smithfield Street Bridge to connect to Downtown. The 1995 renovation converted the former streetcar alignment to bus and automobile traffic. During modernization of the streetcar network in the 70s and 80s, many streetcar routes were converted to bus routes. Two major streetcar lines were converted to light rail lines which included the construction of a short subway in Downtown Pittsburgh. Rather than crossing the Monongahela over the Smithfield Street Bridge, the Panhandle Railway Bridge was converted for light rail use. A ramped connection was made between the Panhandle Bridge and the Mount Washington Transit Tunnel to connect the South Hills to the downtown subway and eventually across the Allegheny to the North Shore. The Station Square transit center was constructed on this connection, which runs parallel to East Carson Street.



An inbound streetcar approaches the Smithfield Street Bridge in 1972. Today's Station Square transit center was built in place of the building in the background. Source: Robert G. Pflaum Photograph Collection, University of Pittsburgh

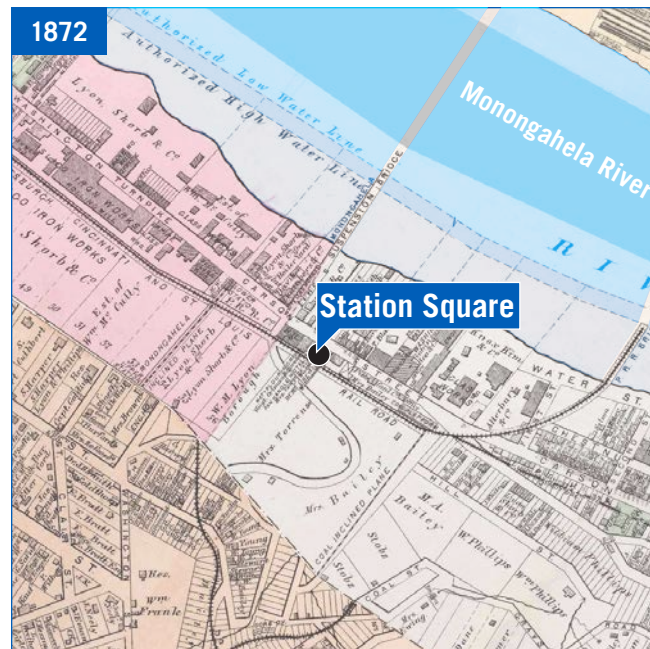

The 1872 map shows the early development of factories, warehouses, and coal mines along Carson Street as well as the original shoreline of the Monongahela. Source: ESRI Peoplemaps

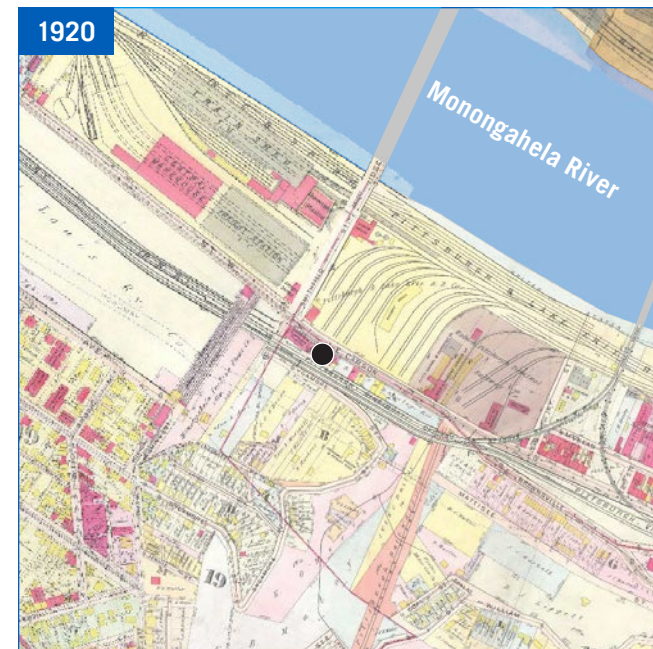

The 1920 map shows the conversion of this area into a freight and passenger rail hub and the reconstructed shoreline of the Monongahela. Source: ESRI Peoplemaps



The 1939 aerial view shows the railyards and warehouses of this area near the peak of the rail industry. Source: ESRI Peoplemaps

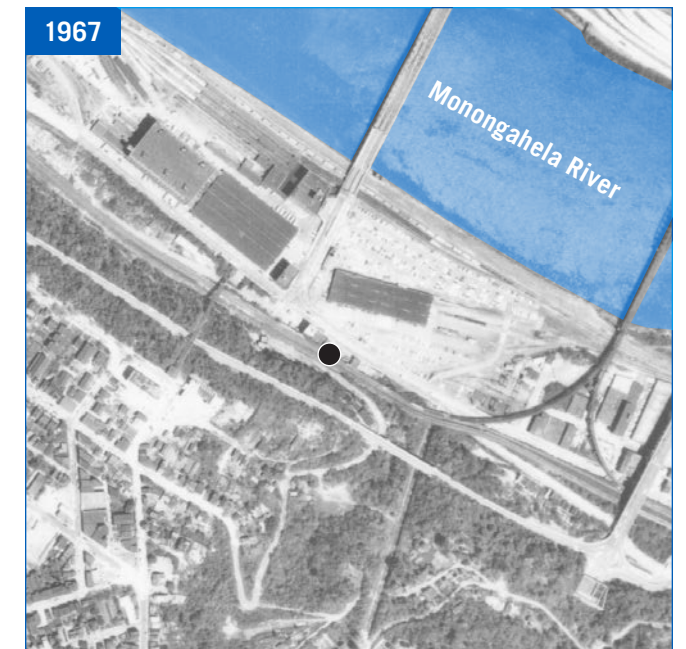

The 1967 aerial view shows the conversion of the eastern railyards and warehouses into parking lots. Source: ESRI Peoplemaps

STAKEHOLDERS AT STATION SQUARE

Stakeholder input was an essential part of this process. Community groups, elected representatives, City and regional agencies, key property owners, and the general public were invited to participate. A detailed list of stakeholders/organizations is included within the appendix of this report.

WHAT THE RIDERS SAY

Where are you coming from/
where are you going?

How many miles do you normally travel to get to/from this facility?

What barriers/obstacles did you encounter as you make your way to this facility?

What would you like to see that would make this station better?

Between Work and Home	77.4%
All Other Combinations	22.6%

Less than 1 Mile	23.5%
Greater than 1 Mile	76.5%

None	68.2%
Traffic Danger	17.9%
Long Waits	7.5%
Sidewalks	6.9%

Design	35.7%
Information	28.0%
Safety	19.6%
Amenities	16.1%
Pathways	12.5%

Based on a 2016 survey performed by the Planning and Evaluation Department. Sample size of 155 of 1390, confidence level of 95%, confidence interval of 7.42.



Members of the public meet with Port Authority and their consultants to develop action plans related to the Station Square area.

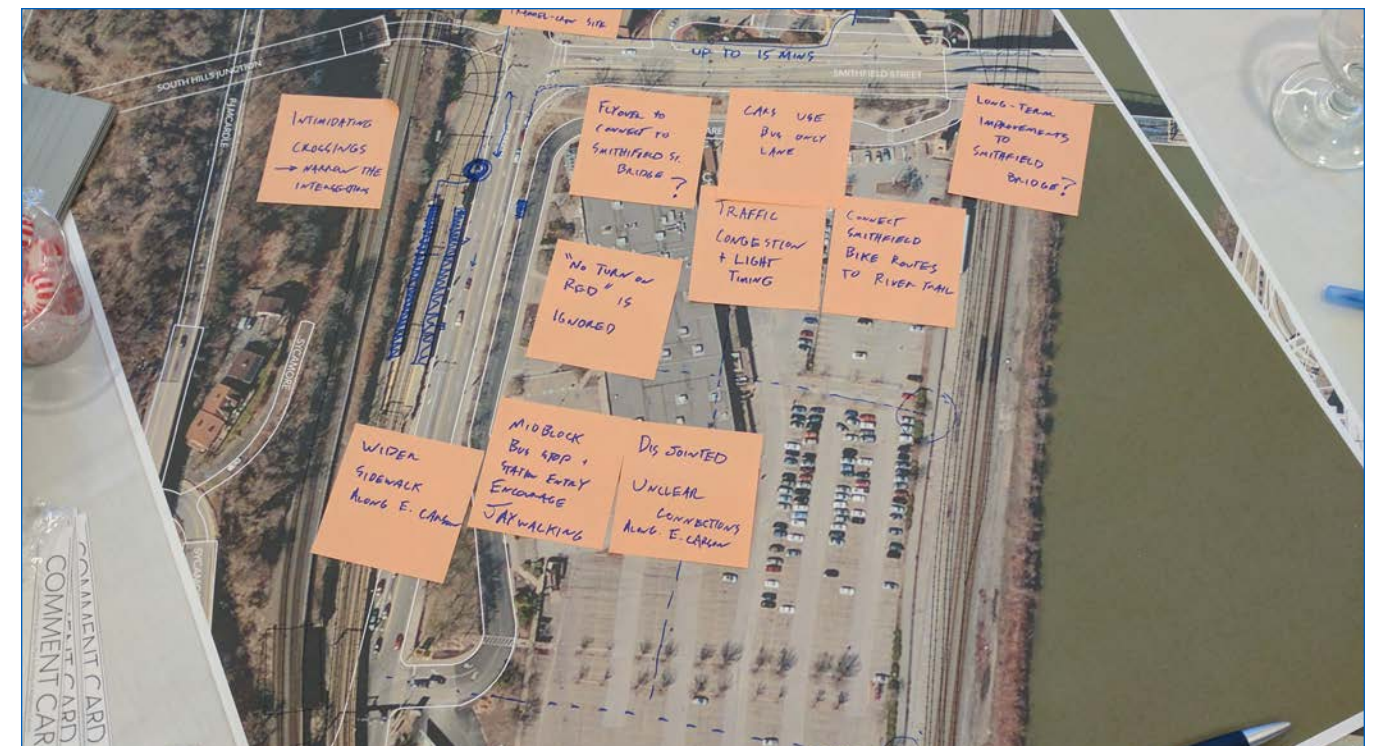

Members of the public met with the project team for workshops in June 2017 to discuss challenges and opportunities in the Station Square area.

2.



STATION AREA PLAN

2.1 NEIGHBORHOOD CONTEXT

The neighborhood context at Station Square is particularly relevant since the surrounding development exemplifies some of the traits of successful TOD: higher density, mixed-use with pedestrian access via a riverfront trail system (Three Rivers Heritage Trail) and a direct link to downtown via the Smithfield Street Bridge.

The Station Square transit center occupies a critical location within the Pittsburgh region; it is separated from the central business district by the Monongahela River, is directly adjacent to a destination mixed-use development (Station Square), and lies along Carson Street – a major commercial corridor that runs through the South Side neighborhoods. In 1976, Station Square was developed as a historic adaptive reuse project by the Pittsburgh History and Landmarks Foundation (it is currently owned by Forest City Enterprises). The development includes a Sheraton Hotel as well as several large-scale restaurants, including The Grand Concourse, the Freight House shops, office space, and a dock that houses the Gateway Clipper fleet.

The South Side which is located to the east of Station Square, is divided into two distinct neighborhoods – the South Side Flats which is roughly one square mile, and includes the East Carson Street corridor - and the South Side Slopes. East Carson Street is home to a variety of bars, restaurants, and live music venues and is also a nationally designated Historic District. The South Side Slopes is primarily residential and includes a variety of housing types.

A new mixed-use development, Glasshouse, recently broke ground at the northeast corner of East Carson Street and Smithfield Street. The first phase of the new development by the Trammell Crow Company will have 320 multi-family units, with additional phases planned to include a mix of commercial uses. The first phase, with expected completion in 2019, will be located adjacent to the Monongahela River and the Three Rivers Heritage Trail, with future phases planned for the northern portion of the parcel, directly across East Carson Street from Station Square Station. The development will also incorporate a Healthy Ride bike share station.

Another major initiative planned for the area is the redevelopment of the Terminal Building, located at 333 East Carson Street on the South Side (currently known as River Walk Corporate Center). The Highline, as the project is called, is being developed by McKnight Realty Partners and is slated to include 500,000 square feet of office space and 100,000 square feet of retail space. Plans include redevelopment of an existing elevated roadway as a new public open space.

Communities to the south of Station Square are separated from the station by railroad tracks and a significant change in elevation. The neighborhood located at the top of the Monongahela Incline is known as Mount Washington, and is a major tourist destination because of its panoramic views of the city. It's a primarily residential community with commercial development along Shiloh Street and Virginia Avenue. The neighborhood is also home to Emerald View Park, a regional park with ample trails and other amenities. A large development site adjacent to the Monongahela Incline Upper Station and Shiloh Avenue business district presents a highly visible and catalytic opportunity in the future.

West Carson Street continues past Highmark Stadium, a 3,500-seat soccer stadium which is home to the Pittsburgh Riverhounds of the United Soccer League, ultimately connecting to the West End Bridge and Saw Mill Run Boulevard.



The Glasshouse, main entry shown above, is a mixed-use development that has recently broke ground at the northeast corner of East Carson Street and Smithfield Street. Source: Hord Coplan Macht

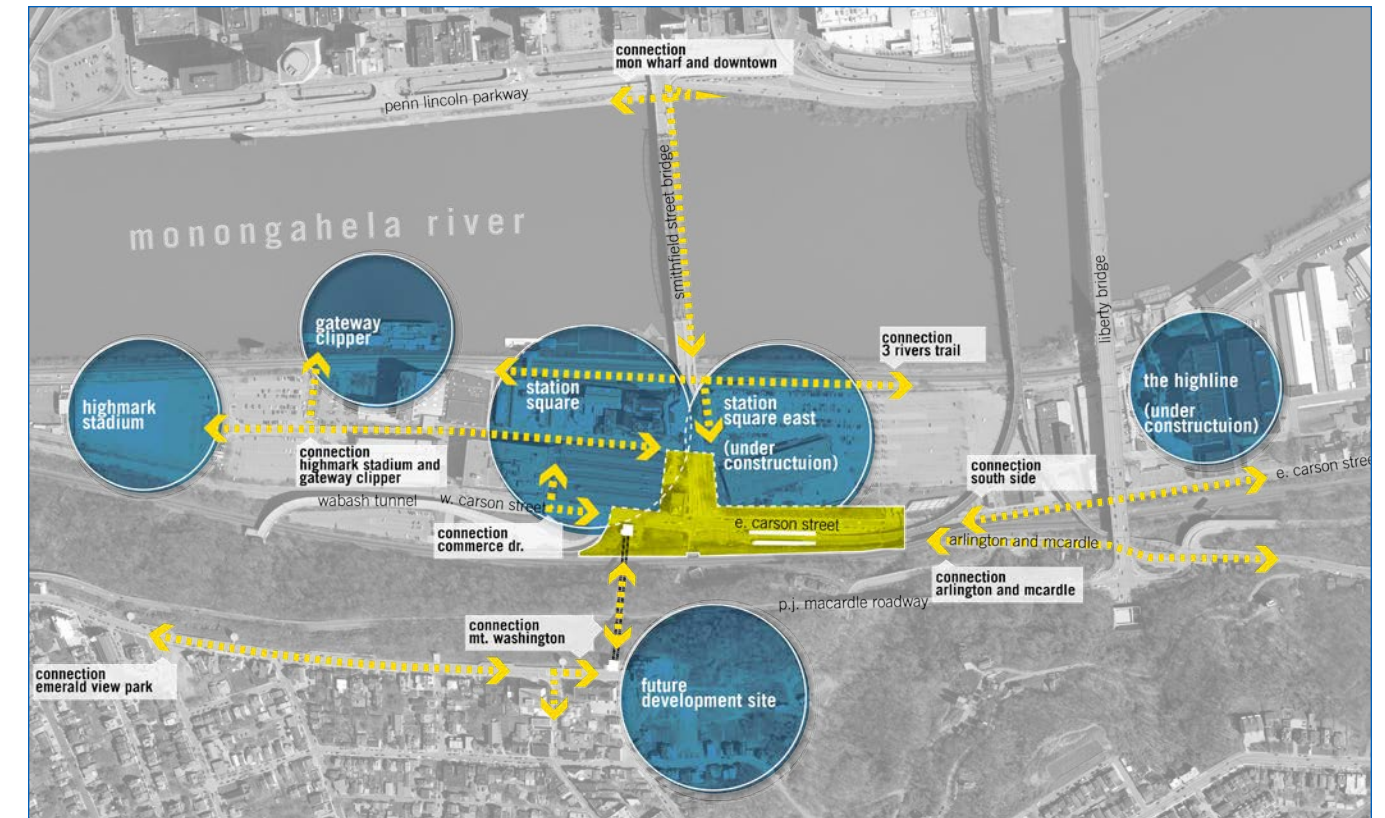

The Station Square location relative to regional destinations.

Station Square transit center (yellow square) Connections (yellow dashed arrow) Destinations (blue circle)

NEIGHBORHOOD CONTEXT: MOBILITY

Due to geography with the hillside to the south and river to the north, there are many barriers within the urban fabric of the area around Station Square. Therefore, transit plays a key role in linking these various areas together. With its proximity to downtown and destination entertainment, retail, and restaurant uses, the area experiences congestion. The bus, rail, and incline transit options make Station Square a transit center with the third-highest ridership in the Port Authority system and an important way for people to connect to other parts of the region.

Carson Street (Pennsylvania Route 837) is a four-lane urban principal arterial that runs in the east-west direction along the Monongahela River in Pittsburgh. It separates Station Square Station and the Monongahela Incline Lower Station along the south side of Carson Street from the development along the north side. It has a posted speed limit of 25 mph east of Smithfield Street and 35 mph west. Constrained by geography, it is the only road along the south shore of the Monongahela or Ohio Rivers that connect City neighborhoods and adjacent suburbs, which leads to congestion issues during peak times of the day. East Carson Street connects the densely-developed South Side neighborhoods and West Carson Street connects the primarily residential West End neighborhoods. East and West Carson Streets are separated by Smithfield Street, a north-south road which crosses the Monongahela River into downtown. The Smithfield Street Bridge, a historic structure, was built at the site of a previous bridge in 1883 and widened in 1896 and in 1911. It has a posted weight limit of 23 tons. Traffic patterns vary by time of day on the three-lane bridge with a bus-only inbound lane in the morning and two outbound lanes at all other times. It is typically congested during peak periods. The bridge has a four-lane approach to Carson Street, with lane assignments / traffic patterns changing based on time of day.

Arlington Avenue is an east-west road connecting Carson Street

from a diagonal intersection to the hilltop neighborhoods of Allentown, South Side Slopes, and Arlington. It is a relatively steep hillside commuting street with few single-family homes, so it is less frequently used by pedestrians than the other roads near the station. Historically, it once ran to Washington (Pennsylvania), though its function as an intercity road was diminished with the opening of the Liberty Bridge and Tunnel and the Fort Pitt Bridge and Interstate system. Arlington Avenue is crossed by P. J. McArdle Roadway which connects the South Side to Mount Washington. McArdle Roadway provides a vehicular link from Arlington Avenue to the Liberty Bridge, and there are stairs from the bridge to Arlington Avenue.

The Wabash Tunnel is a block west of Smithfield Street. It is a former railroad tunnel that was converted into an HOV-only facility with a single directional lane. To increase utilization, the HOV restrictions were removed. The tunnel is not utilized on a regular basis by transit vehicles, but it is utilized in detour situations and for other bus movements.

Carson Street provides limited mobility for non-motorized transportation. Beyond the station area, East Carson Street has an outbound bicycle lane on its south side and a sidewalk on its north side. West Carson Street has neither sidewalks nor bicycle infrastructure between Station Square's Commerce Drive and the Fort Pitt Bridge, a gap of a half mile. Smithfield Street is a key link in the street network, being the only downtown Pittsburgh surface street to cross the Monongahela River. It has two wide sidewalks well used by pedestrians and cyclists.

The bus- and light rail-only transit tunnel lines up with Smithfield Street south of the intersection of Carson Street. It was bored in 1904 through Mount Washington to bring streetcars from the South Hills across the bridge and into the city. As part of Pittsburgh's 1985 downtown subway project, the light rail was moved off the Smithfield Street Bridge to the Panhandle Bridge a quarter of a mile east, and the former light

rail side of the Smithfield Street Bridge was converted to a northbound vehicular lane in 1994. The Station Square Station was built along the connecting track between the Transit Tunnel and Panhandle Bridge. The Blue and Red lines serve the station, connecting Downtown and the North Shore with the South Hills. In 1977 the South Busway was constructed to provide faster bus service from the South Hills into Pittsburgh, which runs through the Transit Tunnel. Upon exiting the tunnel, inbound buses turn right into the Station Square Station and stop at their own designated shelter. Then they proceed behind the LRT platform along a one-way ramp to Carson Street opposite Station Square Drive at the Arlington Avenue intersection. Inbound buses turn left to East Carson Street, stop midblock across from the LRT station, and turn right onto the Smithfield Street Bridge. Southbound buses proceed straight from their stop on the Smithfield Street Bridge approach and into the transit tunnel. The route is used by the Y1, 39, 40, 41, 44, Y45, Y46, Y47 and Y49, with the Y-labeled routes continuing to the South Busway. Additionally, routes 48 and 51 use Smithfield Street and continue along East Carson Street. Route 43 uses the Smithfield Street Bridge and continues on Arlington Avenue.

The Monongahela Incline first opened in 1870 to provide a pedestrian connection to the Smithfield Street Bridge for the residential Mount Washington neighborhood above. Today it is used by commuters and tourists alike, providing a key link in pedestrian mobility south of Downtown. Beneath the incline, the Norfolk Southern Railroad runs east-west along Mount Washington. It provides freight-only service with no stops in the vicinity of Station Square. The CSX railroad runs along the Monongahela River and also provides only freight service.

The Three Rivers Heritage Trail of the Great Allegheny Passage runs along the south side of the Monongahela River, terminating in Station Square. The Eliza Furnace Trail runs along the north side of the Monongahela River, connecting to a network of trails along the Ohio and Allegheny Rivers. As of 2017-2018, ramps are being constructed from the north side of the Smithfield Street Bridge directly to the trail, thus the Smithfield Street Bridge is becoming an important link in the regional trail network. There are currently no Healthy Ride bike share stations in Station Square, though they are planned as part of the network's 2018 expansion.



Arlington Avenue, East Carson Street, Station Square Drive, and the exit for the busway from the Transit Tunnel converge at one intersection



A view looking west along the Three Rivers Heritage Trail of the Great Allegheny Passage, which is a major pedestrian connector to Station Square from Downtown, South Side Flats, and beyond.

STATION AREA BICYCLE NETWORK

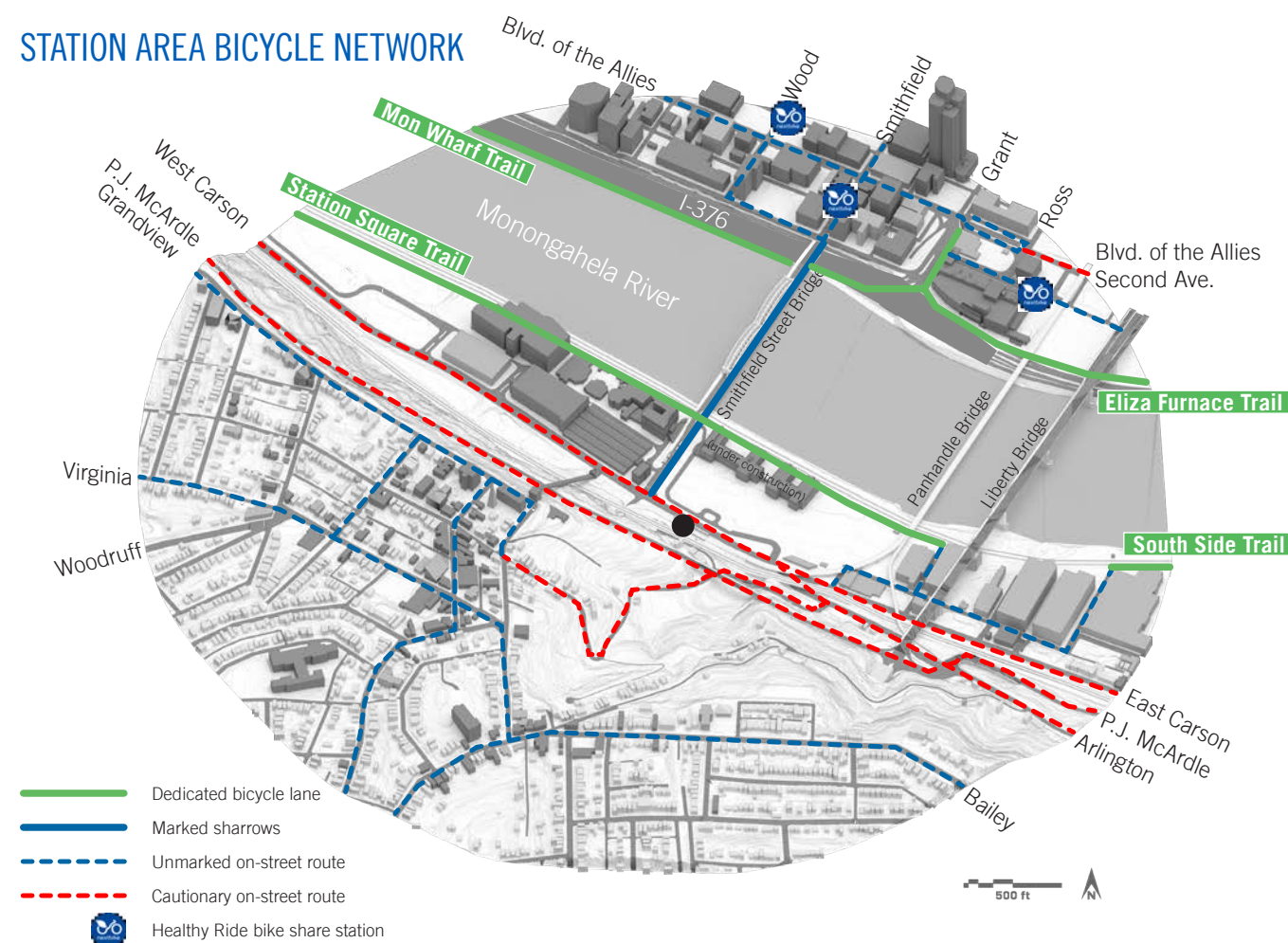

2.2 STATION ACCESS

Analysis of the existing connections to the Station Square LRT and bus station identified challenges individuals face while accessing the transit center. Improvements to roadway connections and streetscapes can leverage additional pedestrian and bicycle use, and help strength station usability, and access to and from existing and proposed developments within the neighborhood.

PENNDOT PLANNED CARSON STREET SAFETY IMPROVEMENTS

PennDOT’s 2019 planned roadway improvements highlighted below focus on safety enhancements for multimodal users along the corridor. Planned improvements to East Carson begin at the intersection of Smithfield Street and East Carson Street continuing east throughout the South Side Flats neighborhood. In the immediate area of the Station Square transit center, the safety improvements called for will:

- Replace signals
- Install leading pedestrian intervals
- Realign a crosswalk
- Relocate a bus stop
- Install tracer lines
- Change the south bound lane configuration
- Install ADA compliant curb ramps
- Install high visibility crosswalks

Many of the same elements are called for further east where the station terminates at the intersection of Arlington Avenue and East Station Square Drive. These improvements will:

- Replace signals
- Add a new crosswalk (west leg)
- Install a leading pedestrian intervals
- Install a flashing yellow arrow
- Add a “Signal Ahead” flashing sign
- Install a sidewalk (south side of East Carson Street)

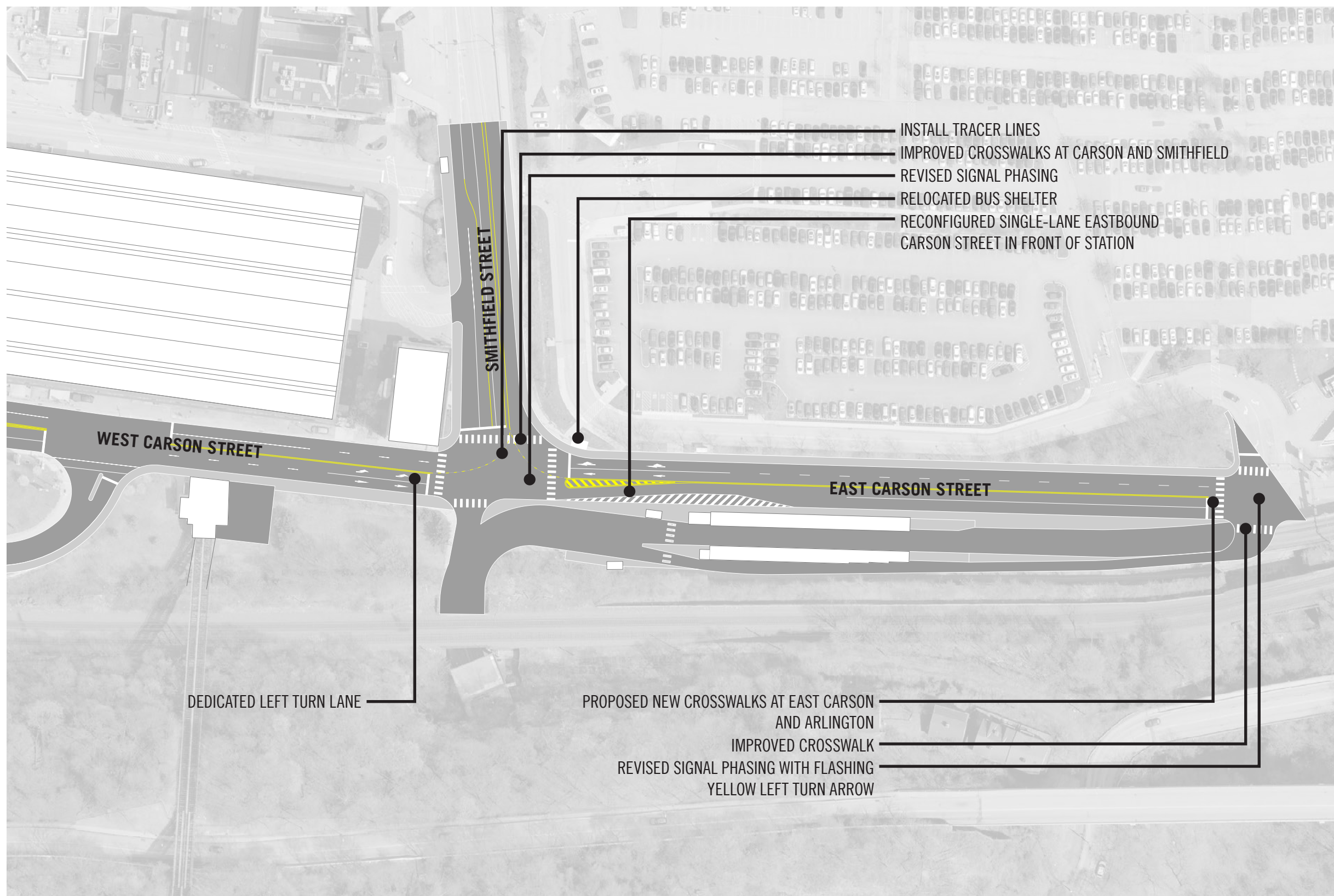

STATION ACCESS: EAST CARSON STREET

Existing Conditions:

- Through Lanes: 4 (2x2)
- Sidewalk Width: 4' to 9'
- Speed Limit: 25 MPH
- Parking: None
- Bicycle Lanes: None

- The pedestrian crossing on East Carson Street (at Smithfield Street) is relatively long, with lengthy wait times, and crosses East Carson Street at an angle.
- There is a tendency to jay walk across East Carson Street since the existing bus shelter located on the north side of East Carson Street is not located near the intersection.

Opportunities

- Station Square functions as a multimodal hub (bus, light rail, and incline converge in one location) for the Pittsburgh region. It is situated directly across from the central business district via the Smithfield Street Bridge, offering an important connection for downtown employees and visitors.
- The Port Authority owns the land underneath the elevated tracks for the light rail system.
- PennDOT has planned safety improvements along East Carson Street.
- Trammell Crow, the developer of the new Glasshouse development, has a vested interest in enhanced multimodal connections at the Station Square transit center since the project is directly adjacent to the station.

Challenges

- The pedestrian walkway on the south of East Carson Street is not buffered from automobile traffic and terminates with a large concrete retaining wall.
- The intersection at East Carson Street and Arlington Avenue is difficult to navigate as a pedestrian due to the angle of Arlington Avenue as it intersects with East Carson Street, the presence of multiple roadways (including the South Busway) and the absence of dedicated crosswalks in all directions.
- The elevated tracks for the light rail system create an unwelcoming pedestrian environment near the intersection of East Carson Street and Arlington Avenue.
- The sidewalk that runs in front of the LRT station becomes extremely narrow near the existing railing and light pole standards (at the corner of East Carson Street and Smithfield Street).



Looking east along East Carson Street to Arlington Avenue



View of the intersection at East Carson Street, Arlington Avenue, and East Station Square Drive



Bus entrance to East Carson Street at the intersection of East Carson Street, Arlington Avenue, and East Station Square Drive



Looking east along East Carson Street at Station Square Station entrance



- Station Square transit center
- East Carson Street

STATION ACCESS: EAST CARSON STREET

Currently, the right-of-way that runs along the north side of East Carson Street, parallel to East Station Square Drive, is relatively wide (approximately 18 feet wide). Since PennDOT has proposed moving the bus shelter to the corner with Smithfield Street, and the new mixed-use development will be constructed adjacent to the walkway, it is an important pedestrian access point. As a result, streetscape improvements are proposed and include a vegetated buffer running adjacent to East Carson Street and a sidewalk that will be located adjacent to the newly constructed buildings. Construction of a vegetated buffer eliminates the need for pedestrian guardrails.

Similarly, along the south side of East Carson Street, streetscape improvements are proposed that enhance the pedestrian experience, including construction of a vegetated buffer with roadside bioretention that collects and treats roadway stormwater.

Existing Roadway Cross Section - East Carson Street



Proposed Streetscape Improvements - East Carson Street

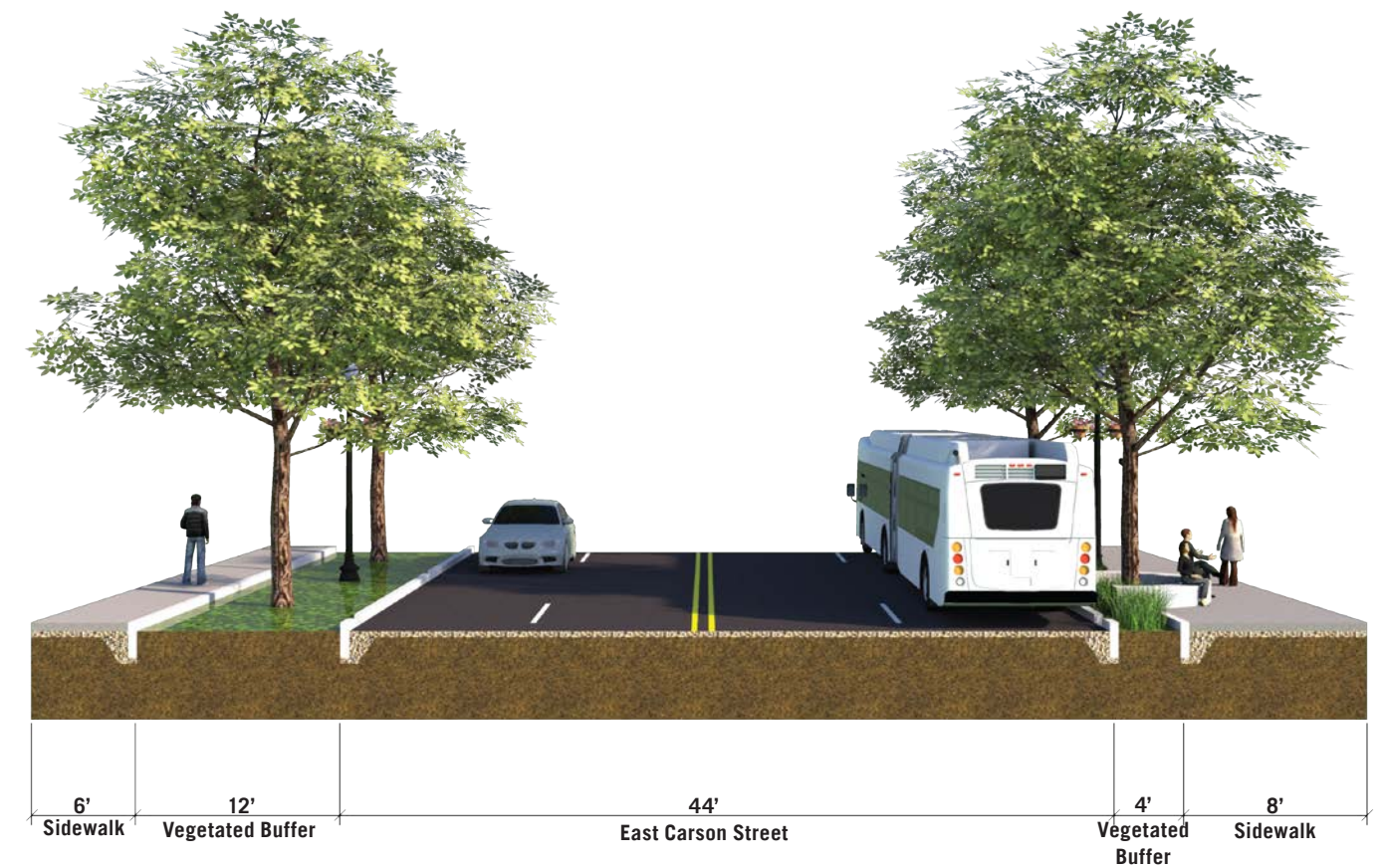

STATION ACCESS: WEST CARSON STREET

Existing Conditions:

- Through Lanes: 4 (2x2)
- Sidewalk Width: 6' to 9'
- Speed Limit: 35 MPH
- Parking: None
- Bicycle Lanes: None

Challenges

- The pedestrian walkway along West Carson Street is not buffered from automobile traffic.
- The informal pedestrian connection located along the north side of West Carson Street is difficult to navigate; the existing pathway is relatively narrow and undefined in sections.
- Similar to access via East Carson Street, the pedestrian crossings are relatively long, increasing the amount of time that pedestrians spend within the cartway.
- The view when exiting the Incline Station is of the loading docks and back entrance of the Freight Shops at Station Square.

- The existing railing that runs between the incline and LRT station along West Carson sits behind to a row of cobblestone and creates an underutilized section of the sidewalk; removal of the railing could potentially increase the width and function of the sidewalk leading to the Incline Station.
- There is no marked crosswalk across West Carson Street upon exiting the Incline Station, however, there is a signal to the Wabash Tunnel entrance.

Opportunities

- Forest City, the owner of the Station Square development, has a vested interest in enhanced multimodal connections at the Monongahela Incline Lower Station since the development runs adjacent to West Carson Street.
- The Monongahela Incline is a visitor destination, attracting approximately 650,000 visitors annually.
- The Port Authority controls the property located adjacent to the incline station.



Station Square transit center ■■■■■ West Carson Street
■■■■■ East Carson Street



View upon exiting the Monongahela Incline Lower Station

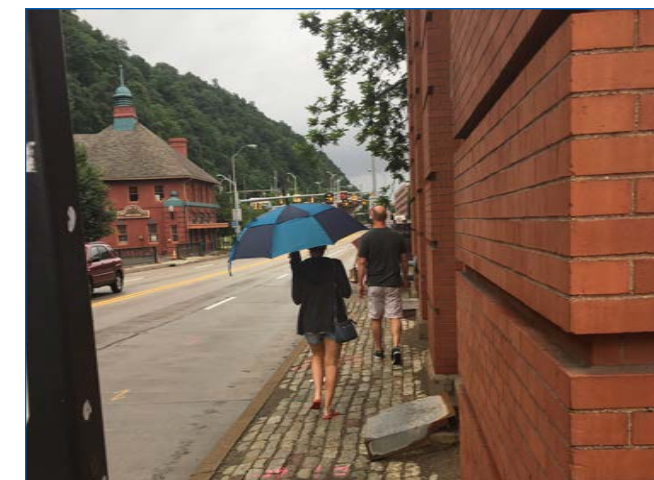

View of pedestrian access on the north side of West Carson Street



Pedestrian view along West Carson Street where the gates to the staff parking for the incline cross the sidewalk

STATION ACCESS: SMITHFIELD STREET

Existing Conditions:

- Through Lanes: 3 (2x1)
- Sidewalk Width: 7' to 10'
- Speed Limit: 25 MPH
- Parking: None
- Bicycle Lanes: None

Opportunities

- Reallocating roadway space along the bridge's south side can reduce crossing distances and improve pedestrian connections near the station area.
- Increasing the turning radius at both corners of Smithfield Street will allow for corner bump outs.
- Adding bicycle infrastructure can improve connectivity to both the station area and the regional trail network.

Challenges

- Smithfield Street has variable lanes, wide pavement areas, and confusing traffic patterns.
- The bridge is an important link in the regional bicycle trail network, yet lacks bicycle-specific infrastructure.
- There are no direct pedestrian connections from the east sidewalk to Station Square or the bicycle trail.
- Intersections on both sides of the bridge have long cycle lengths, high turning traffic volumes, and confusing cycles.
- Smithfield Street is a key city artery providing the only direct connection south from downtown.



Intersection of Carson Street and Smithfield Street Bridge



- Station Square transit center
- West Carson Street
- East Carson Street
- Smithfield Street



Diagram highlighting the possible reallocation of roadway space along the bridge's south side to reduce crossing distances. The dashed white lines highlight the existing location of the curb along Smithfield Street.

2.3 STATION ANALYSIS

The following site analysis focuses on property owned by the Port Authority at Station Square, including the streetscape around Station Square LRT and bus station, and the land surrounding the Monongahela Incline Lower Station.

MONONGAHELA INCLINE LOWER STATION

Challenges

- The front door of the Monongahela Incline Lower Station blocks the sidewalk when opened.
- Pedestrian access is limited west of the station. Pedestrians that wish to cross Carson Street at the station exit or into Station Square at Commerce Drive face “No Pedestrian” signs.
- The narrow ramped sidewalk into the station becomes crowded during heavy use.
- When the gates are open to the employee lot from West Carson Street, they block the main sidewalk to the station.
- The incline becomes overwhelmed with customers, especially during peak events, yet with adjacent roadway congestion it is challenging to successfully operate relief shuttles.
- There is little visual connection between the Station Square LRT and bus station and the Monongahela Incline Lower Station.
- The property located next to the incline station must be able to accommodate maintenance vehicles.
- The parking lot located next to the incline station makes it look like the rear entrance even though it is the most visible facade when accessing from Smithfield Street

Opportunities

- The Port Authority controls the property located next to the Monongahela Incline Lower Station.
- The Monongahela Incline Lower Station is one of Pittsburgh’s most popular tourist destinations.
- The incline provides an important link between Mt. Washington and Station Square.
- Management at Station Square could create a gateway of visually interesting features at the back of the Freight House Shops across the street from the incline’s exit.
- Many commuters are making the connection from the incline to other modes of transportation including light rail and walking over the Smithfield Street Bridge into downtown.



Looking west toward the Monongahela Incline Lower Station along the sidewalk.



View of the exiting green hillside adjacent to the Monongahela Incline Lower Station.

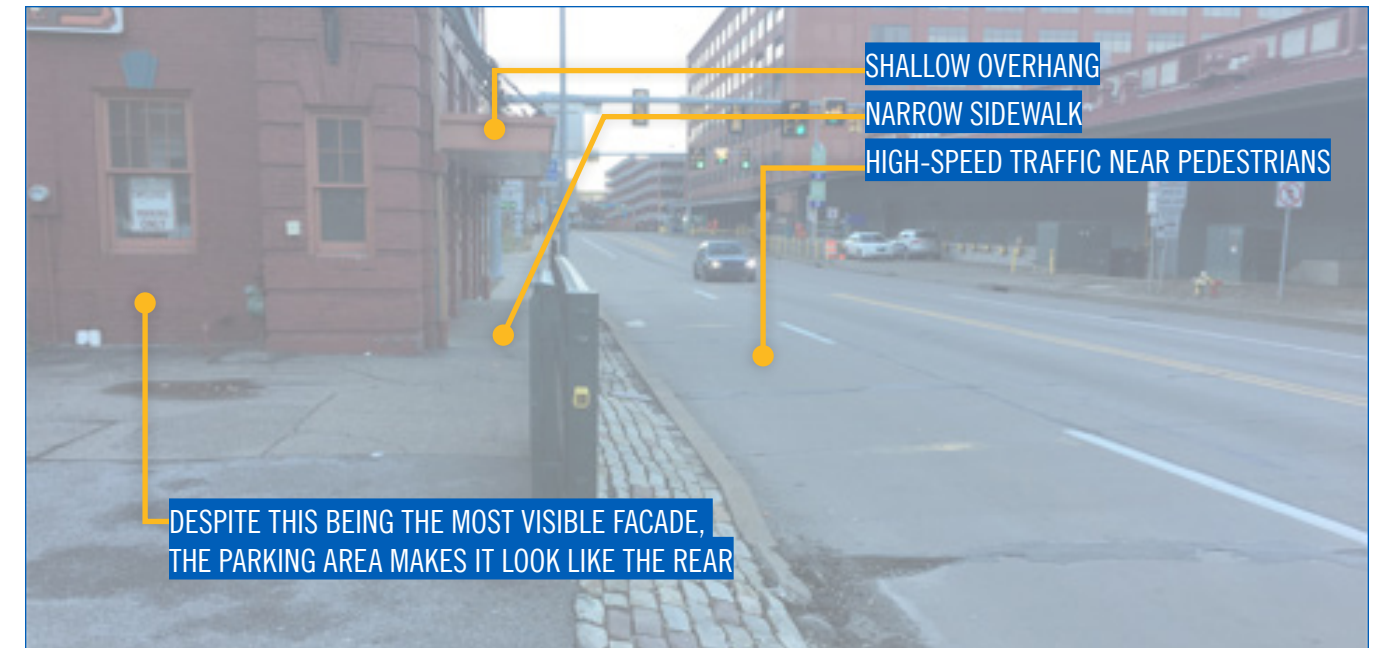

Highlighted areas show different challenges surrounding the pedestrian approach to the lower incline station.

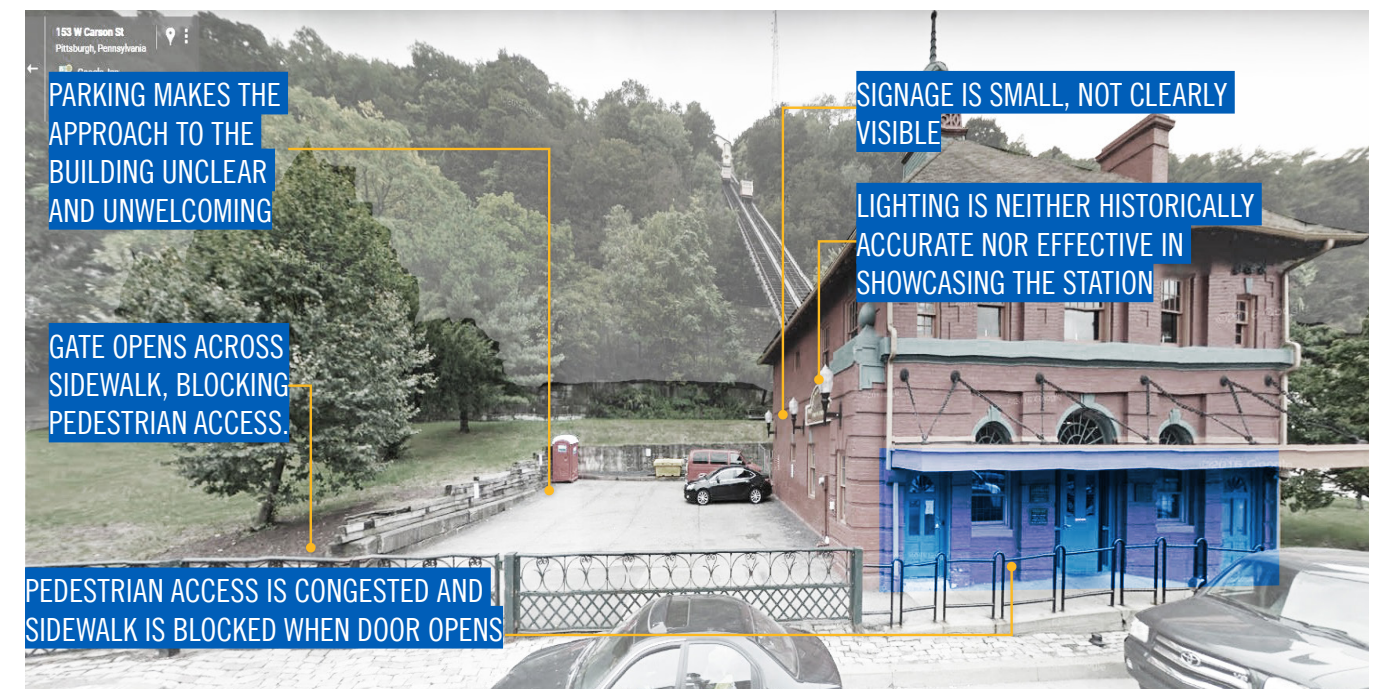

Highlighted areas showing different challenges surrounding the lower incline station.

STATION ANALYSIS

STATION SQUARE LRT AND BUS STATION

Challenges

- The visual approach to the Station Square LRT and bus station is confusing, with competing signage and station amenities.
- The station design is dated and can feel dark.
- The bus shelter located next to the station is disconnected and not consistent with the design of the station.
- Similarly, the South Busway platform that is located across the busway, adjacent to the retaining wall, feels remote and unwelcoming.
- No bus pull-offs are present, resulting in buses blocking through traffic on Carson Street when they stop.
- The station access is directed towards Station Square and Smithfield Street and away from the South Side neighborhood to the east.

Opportunities

- The Port Authority controls the property.
- The Station Square LRT and bus station experiences high traffic because of its central location near a large mixed-use development and proximity to the central business district.
- PennDOT's reconfigured single-lane on eastbound Carson Street offers an opportunity for improved access for transit users.
- The LRT station structure is in relatively good condition.

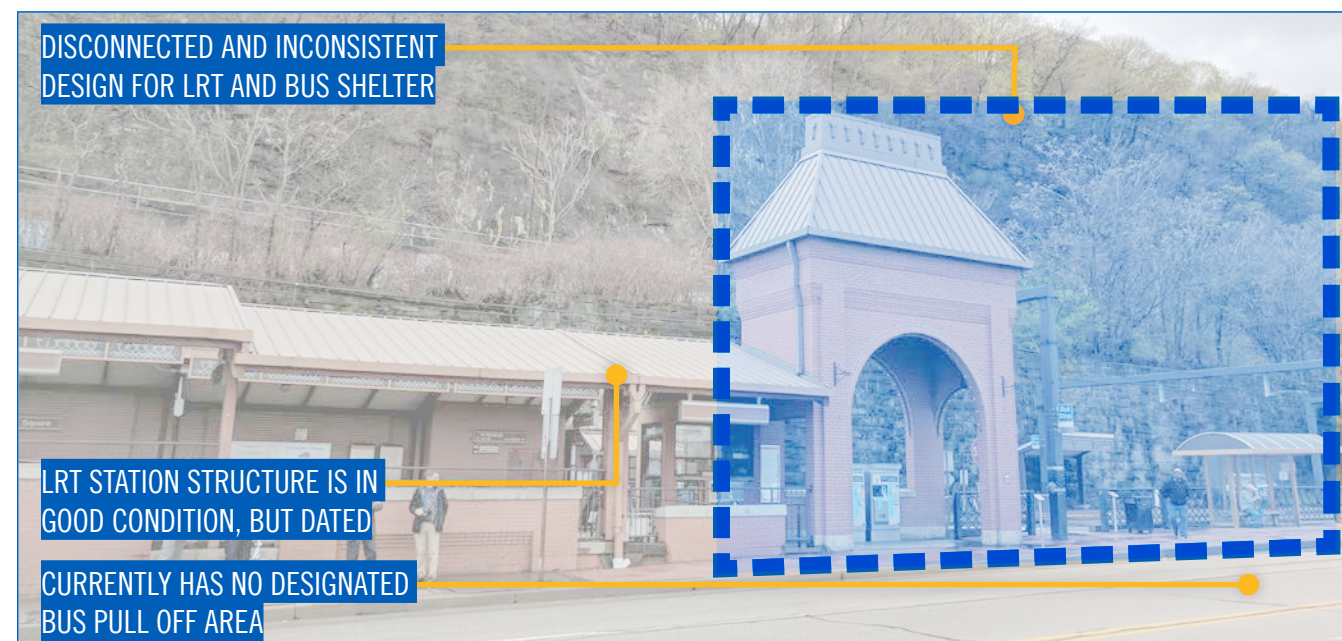
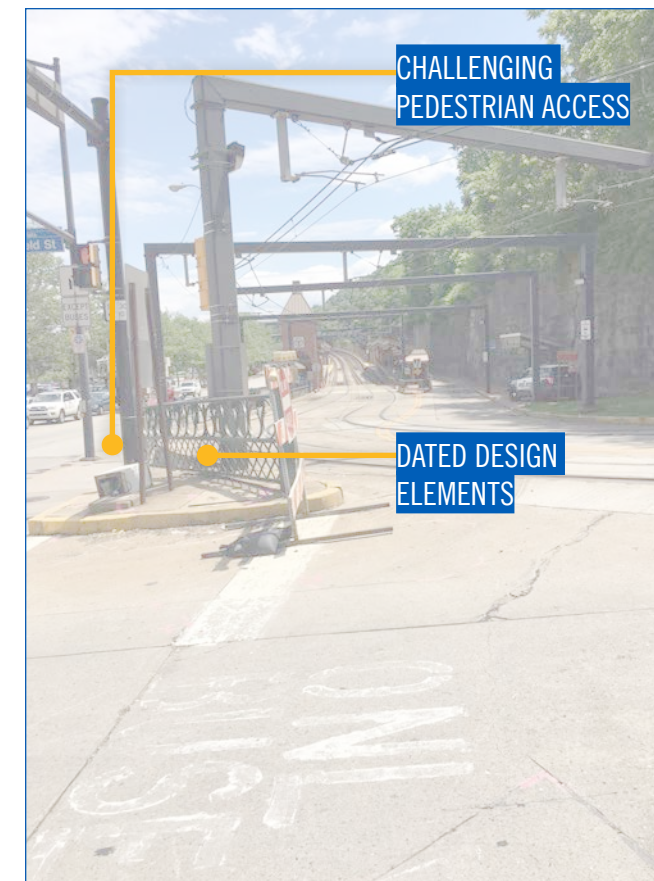
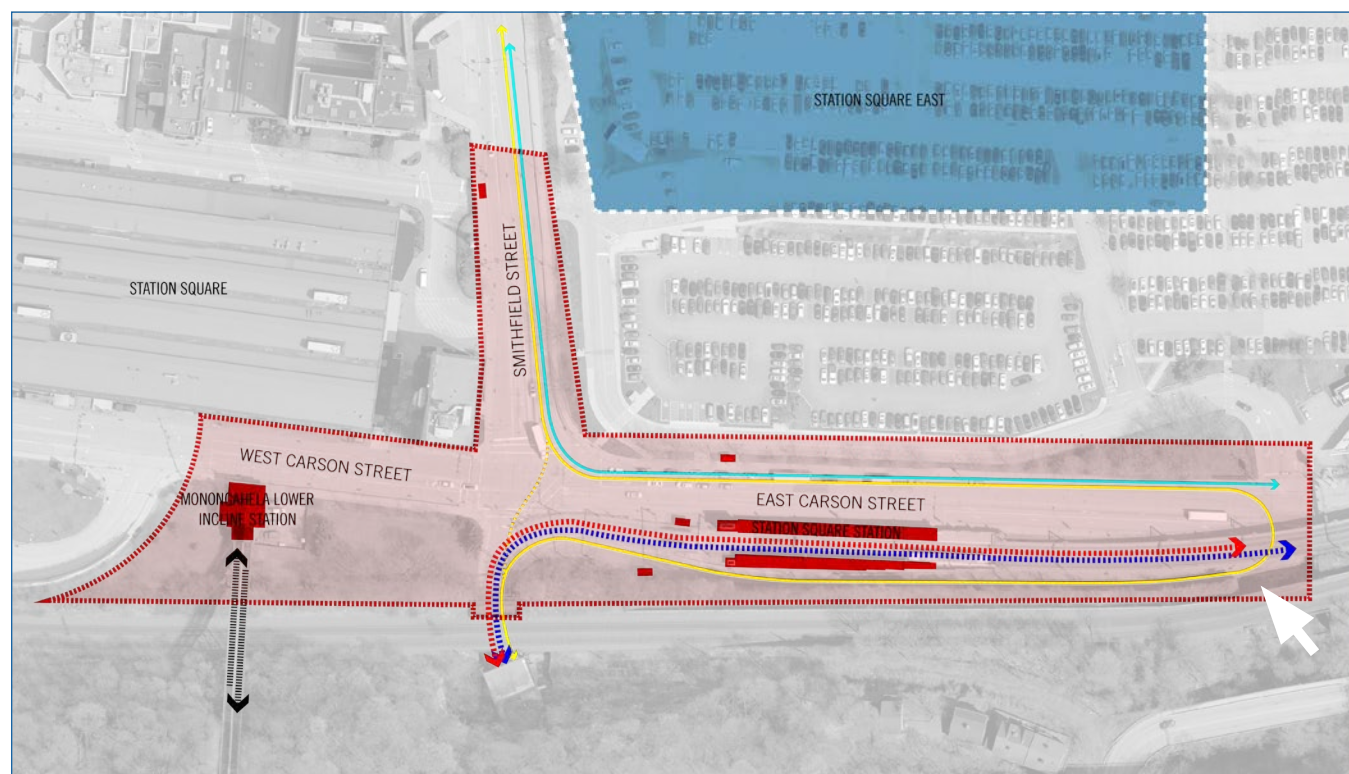

Highlighted areas showing different opportunities and challenges surrounding Station Square Station.

3.



STATION CONCEPTUAL DESIGN

3.1 TRANSIT CENTER CONCEPTUAL DESIGN

The Station Square transit center is made up of light rail, bus, busway, and incline transit service, yet they function largely as separate facilities. Station design focused on the east and west halves of the transit center - which center around the light rail and incline stations, respectively - and how to bring them together. The conceptual design for features on Port Authority property were developed to a 10% completion, providing sufficient information to be integrated into future capital programs.



View along East Carson Street highlighting pedestrian pinch point



Rendering depicts Monongahela Incline Lower Station along West Carson Street

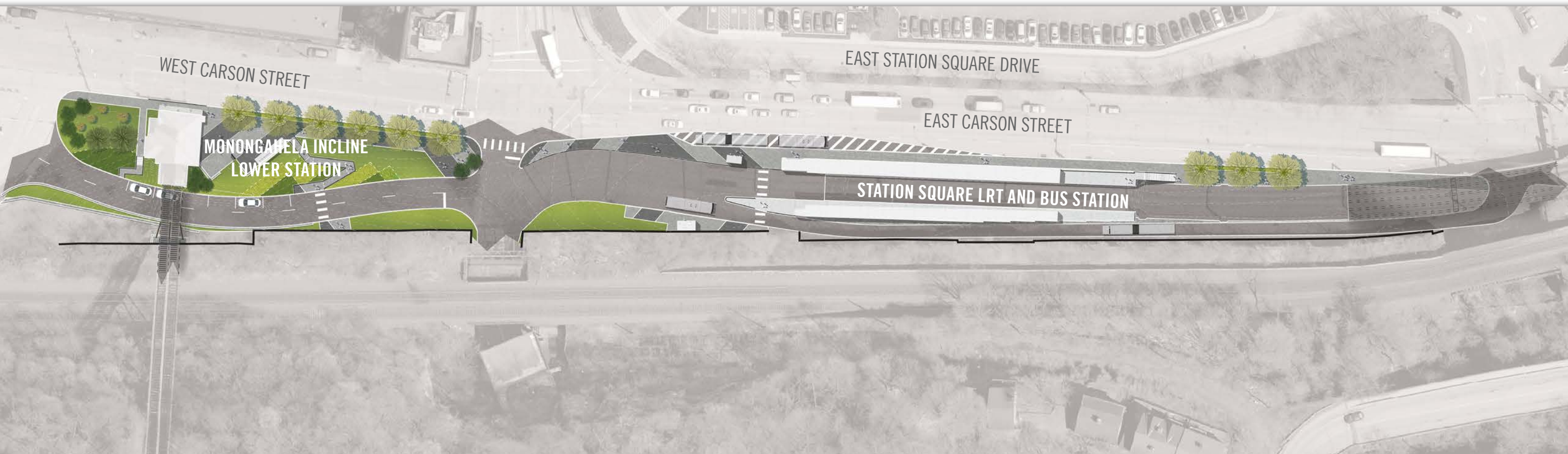

CONCEPTUAL DESIGN: STATION LINK

Currently there is a lack of wayfinding and visible connections between the light rail, buses, and Monongahela Incline. This is a missed opportunity to facilitate transfers and highlight the multimodal nature of the Station Square transit center.

The proposal would integrate station branding and orientation signage into the architectural language of station elements. With centrally located placement, large scale graphics serve as identifiers of the transit assets operating on the site. This enhanced branding and station identity signage would be visible from the Smithfield Street Bridge, adjacent development site, and downtown.

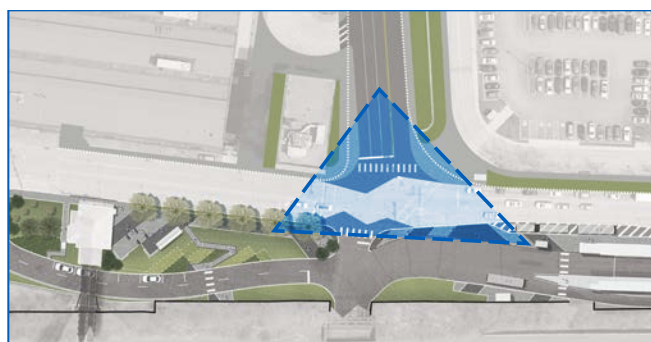

Triangular connection of Station Square transit center

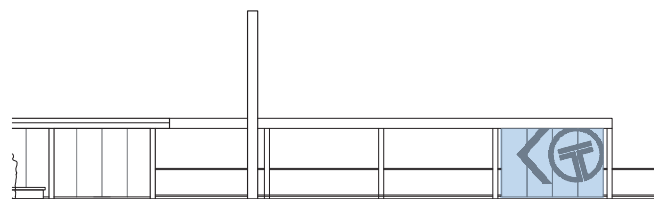

Conceptual elevation of a station identity wall between the tracks and sidewalk along East Carson Street.



Existing view of the intersection of Smithfield Street at Carson Street
Source: Google Streetview

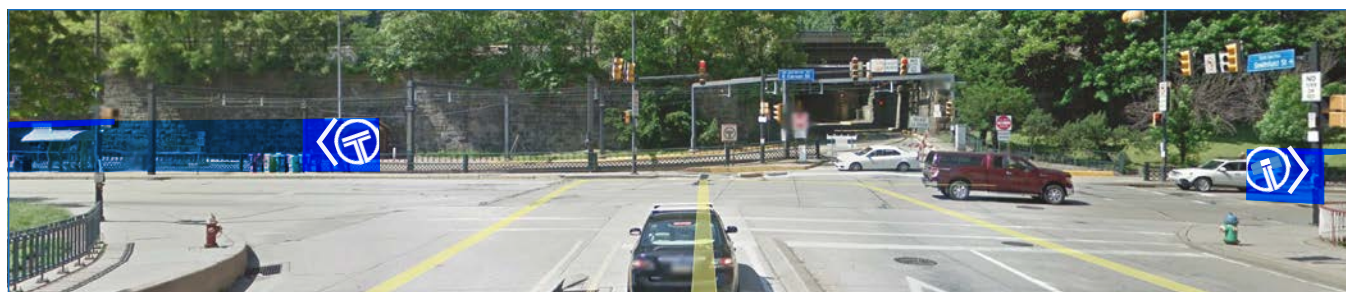

Conceptual view of the intersection of Smithfield Street at Carson Street showing extension of a textured panel wall along the tracks and new branding at the intersection
Source: Google Streetview

SIGNAGE



Example of large scale graphics to identify place and show direction
Source: Selbert Perkins



Example of large scale graphics to identify place and show direction
Source: Selbert Perkins

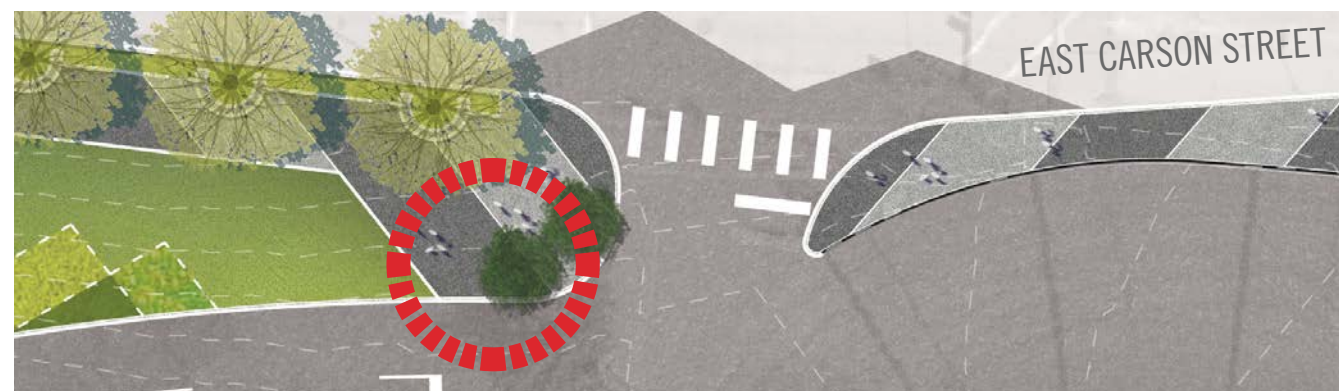

Centrally located placement of conceptual signage to be used as a key identifier of the Station Square LRT and bus station



Proposed concept for displaying historical imagery at the plaza adjacent to the Monongahela Incline Lower Station - using a solid concrete base for weathering and a raw steel support beam to anchor the glass exhibit showcasing transit history



Exhibit example of how to use the existing surroundings and imprint an image of the past to show change over time
Source: Creative Spaces

3.2 INCLINE STATION

MONONGAHELA INCLINE LOWER STATION

The proposed improvements at the Monongahela Incline Lower Station include development of a plaza area next to the station building on the east side. The plaza functions both as a link to the Station Square LRT and bus station and also as a welcoming area for visitors to the station. The plaza area is proposed to include an outdoor exhibit area that depicts the history of the station through displays. In order to accommodate the plaza, the employee parking spaces that are currently located adjacent to the station building will be relocated. The site is sloped, with the high point occurring at the back of the site near the existing retaining wall for the railroad. As a result, the site will be gently graded to accommodate an accessible plaza area.

Plans include development of an expanded sidewalk to the corner of West Carson Street and Smithfield Street. Uniform paving materials for the sidewalk will extend across the tunnel roadway to PAAC's property on East Carson Street in order to visually unite the transit center. Street trees will also be added along West Carson Street to adequately buffer pedestrians from the road. The plaza will be linked to a proposed access road by way of an ADA accessible pathway. The upper pathway will take advantage of the sloped site and cross through a vegetative swale that will capture stormwater on site.

Through the planning process, an operational need was identified and this plan calls for further exploration of a access road adjacent to the incline station. The access road would provide improved maintenance access to incline structures, convenient employee parking, and flexible options for detoured bus service. While this project is independent of improvements to the rider experience, it will seek to improve operational efficiency and the condition of Port Authority property for the benefit of system users. A new loop access road would extend from the Wabash Tunnel ramp to the Mount Washington Transit Tunnel approach. It would run under the incline and serve incline shuttles and service vehicles. Due to the height constraints of the incline and the location of the existing incline station, the roadway is proposed at the southern edge of the

site and would require a new retaining wall in order to ensure hillside stability. A pair of new bus stops is proposed along the access road for incline shuttle users. If desired, the Port Authority could also use the loop for regular bus service in the future. As mentioned earlier, with the elimination of employee parking adjacent to the station, parallel employee parking spaces are proposed for one of the two access road lanes.

Finally, the corner at the entrance to the transit tunnel offers an ideal opportunity for iconic Port Authority signage given its location at the terminus of the Smithfield Street Bridge and midway between the two transit stations.



INCLINE STATION: SITE

STREETSCAPE INCORPORATING GREEN INFRASTRUCTURE

COVERED BIKE RACKS

SEAT WALLS

STATION PLAZA WITH EXHIBIT SPACE

OUTDOOR TICKET VENDING MACHINE

PEDESTRIAN RAILING ALONG CURB LINE
IN FRONT OF STATION

SEAT WALLS ALONG STREETSCAPE

CUSTOM STATION SQUARE SIGNAGE

LARGE PEDESTRIAN COLLECTIONS AREA

SAFE, REPOSITIONED CROSSWALK

WEST CARSON STREET

MONONGAHELA
INCLINE LOWER
STATION

PROPOSED ACCESS ROAD

RETAINING WALL

SINGLE FACE CONCRETE BARRIER

STAIR ACCESS WEST OF STATION

INCLINE STAFF PARKING ALONG ACCESS ROAD

ACCESS ROAD FOR INCLINE SHUTTLES AND MAINTENANCE

ADA RAMP TO ACCESS ROAD AND SHUTTLE ACCESS

VEGETATIVE SWALE

SHUTTLE PASSENGER LOADING AREAS

INCLINE STATION: SITE

PLANTING STRATEGY: MONONGAHELA INCLINE

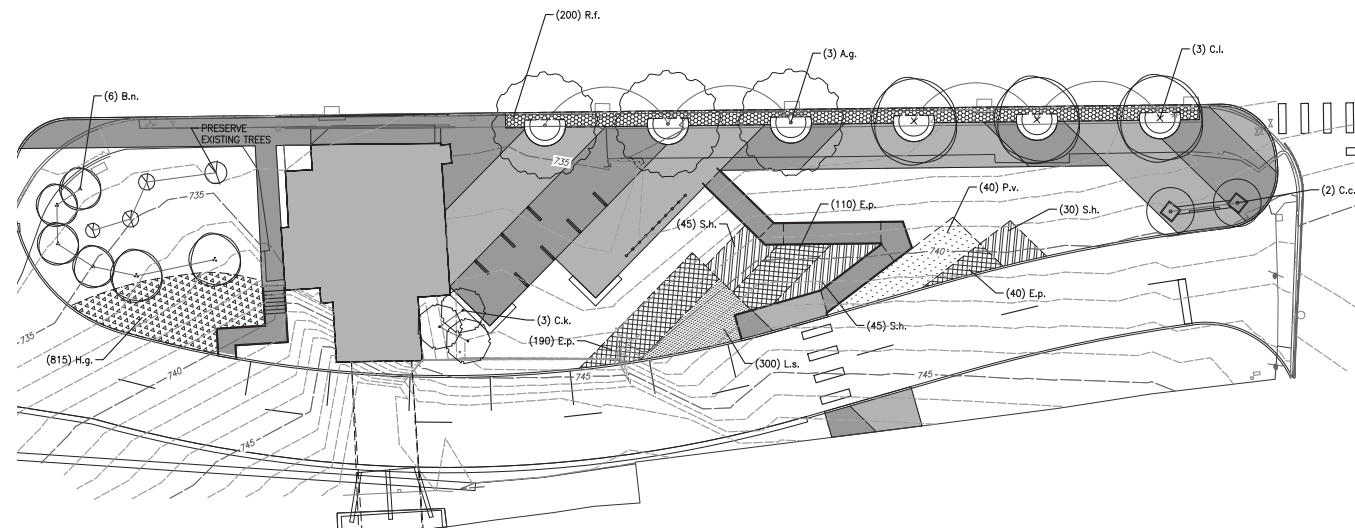

PLANTING STRATEGY: LRT STATION

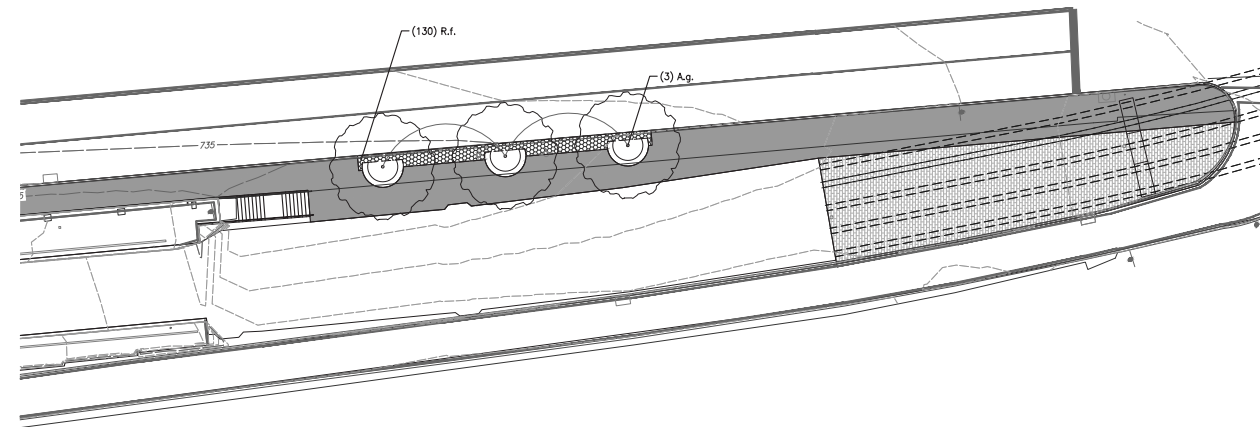

Plant Schedule					
Qty	Key	Botanical Name	Common Name	Size	Comments
Trees					
6	A.g.	<i>Acer griseum</i>	Paperbark Maple	2" cal. B&B	Disease free
6	B.n.	<i>Betula nigra</i>	River Birch	2-1/2" cal. B&B	Clump Form
2	C.c.	<i>Cercis canadensis 'Forest Pansy'</i>	Forest Pansy Eastern Redbud	2" cal. B&B	Disease free
3	C.k.	<i>Cornus kousa</i>	Kousa Dogwood	2" cal. B&B	Disease free
3	C.I.	<i>Crataegus laevigata 'Superba'</i>	Crimson Cloud Hawthorn	2-1/2" cal. B&B	Disease free
Grasses / Herbaceous Plants					
340	E.p.	<i>Echinacea pupurea "White Swan"</i>	Purple Coneflower	#1 Cont.	18" O.C.
815	H.g.	<i>Herniaria glabra</i>	Green Carpet Rupturewort	Flat	12" O.C.
300	L.s.	<i>Lobelia siphilitica</i>	Great Blue Lobella	Flat	12" O.C.
40	P.v.	<i>Panicum virgatum</i>	Switchgrass	#2 Cont.	36" O.C.
330	R.f.	<i>Rudbeckia fulgida var sullivatii 'Goldstrum'</i>	Black-Eyed Susan	#1 Cont.	18" O.C.
120	S.h.	<i>Sporobolus heterolepis</i>	Prarie Dropseed	#1 Cont.	24" O.C.



Acer griseum
Paperbark Maple



Betula nigra
River Birch



Cercis canadensis 'Forest Pansy'
Forest Pansy Eastern Redbud



Cornus kousa
Kousa Dogwood



Crataegus laevigata 'Superba'
Crimson Cloud Hawthorn



Echinacea pupurea "White Swan"
Purple Coneflower

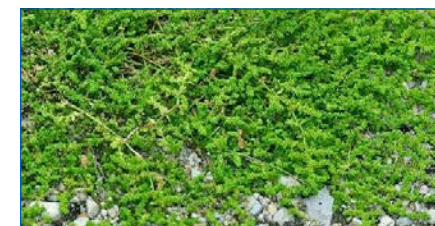

Herniaria glabra
Green Carpet Rupturewort



Lobelia siphilitica
Great Blue Lobella

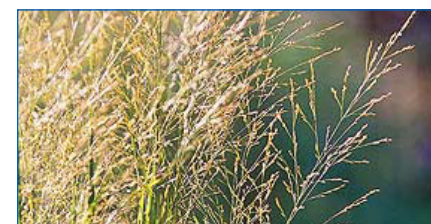

Panicum virgatum
Switchgrass

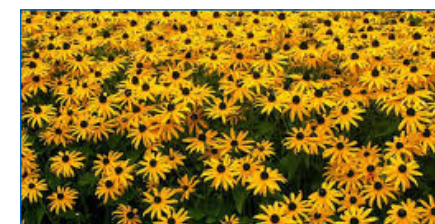

Rudbeckia fulgida var sullivatii 'Goldstrum'
Black-Eyed Susan



Sporobolus heterolepis
Prarie Dropseed

INCLINE STATION: ACCESS AND VISIBILITY



An elevation showing the existing Monongahela Incline lower station facade

ENTRY IMPROVEMENTS

The main entry door would be replaced with a glass sliding door on the inside of the building. This would enable the main door to open for the full width of the doorway, making the experience of entering and exiting the station more comfortable. The sliding door would also be able to open without obstructing the sidewalk. Decorative swing doors would be added on the exterior of this entrance to compliment the facade's historical character. Secondary swing doors would be added on either side of the main entry door. These could be opened by the incline operator for special occasions and in good weather to enhance pedestrian flow into and out of the lobby.

If Carson Street undergoes a road diet in the future, reclaiming extra space would enable a wider walkway, easier access to the station, attractive planters, a potential on-demand ride drop off zone, improved lighting and signage, and an enlarged entry canopy. The sidewalk in front of the station could be made level with ramped sections on either side of the building that integrate with a new plaza between the incline station and the light rail and buses.

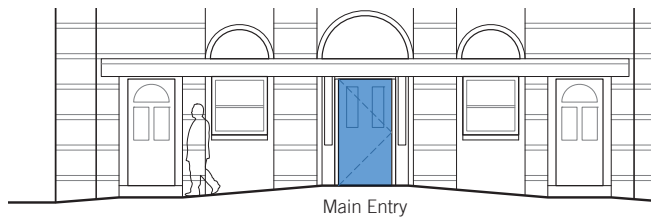

An elevation showing the existing Monongahela Incline lower station entry

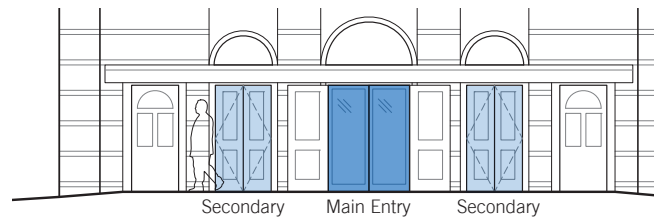

A conceptual elevation showing revised entry doors that would improve the user experience

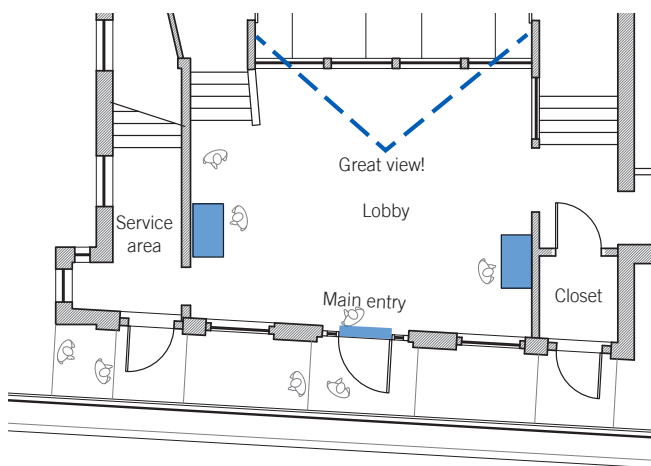

A plan of the existing Monongahela Incline entry. The main entrance door is very narrow and the only access point. Ticket vending machines located in the space can add to congestion when the incline is busy.

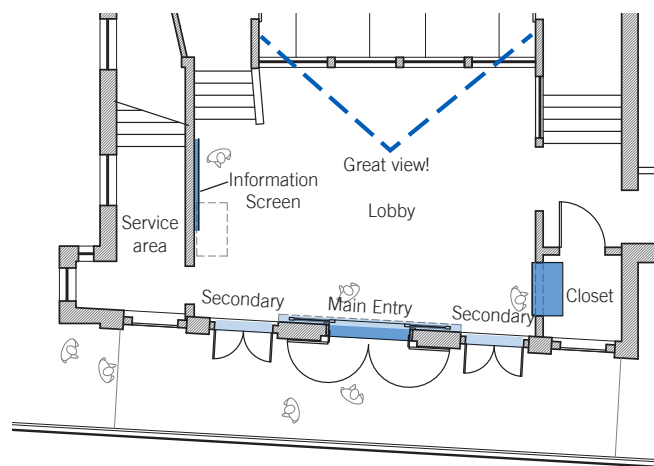

A conceptual plan showing revised entry doors. The main door would be left open on the outside with automatic sliding doors on the inside, providing a wider entry. Additional doors on either side could be opened for major events or holidays when the incline is busy. One ticket vending machine would be relocated to the plaza outside and the other would be recessed into a wall.

EXTERIOR LIGHTING ENHANCEMENTS

Lighting can provide an artful and dramatic identity for the incline lower station and tracks and be visible from viewers on Mt Washington and approaching traffic on East Carson. The tracks are already illuminated at night and the incline lower station can become part of this iconic composition. Lighting should be used to emphasize architectural details of the building without bringing attention to the lighting fixtures themselves.



Carefully integrated architectural lighting helps to highlight historic details. Source: pinimg.com



Lighting fixtures can be integrated within the landscape or carefully integrated with the facade. Small fixtures like these are barely noticeable from a distance. Source: platek.eu

MARQUEE SIGNAGE

Signage should establish the incline lower station's identity as a transit station and should be large and visible from a distance. Large, clear lettering on the station entry's canopy could serve as a highly visible marquee for the station entrance. There is ample precedent for stations to have larger scale signage, mounted high for visibility, such as in Denver's Union Station. However, even smaller letters in a highly visible color and simple font choice, would enhance the station's visibility.



Modern architectural lighting was used in concert with historical fixtures and historic illuminated signage in the restoration of Denver's Union Station. Source: Urban Land Institute



Though smaller in size, this lettering is clearly legible from a distance without detracting from the character of the older buildings around it. Source: Bookmen Stacks Lofts

3.3 LRT STATION

Access at the Station Square LRT and bus station can be challenging; there is a narrowing of the sidewalk along East Carson Street (which is only four feet at its most narrow point) and the inbound LRT and busway platforms are accessible only by a shared at-grade pedestrian crossing that is misaligned with the station's portico. In order to address these concerns, the following elements have been proposed:

- The addition of an east side station entrance to the outbound platform.
- Widening of the sidewalk entrance to the transit station along East Carson to allow for safer and easier pedestrian access. The addition of the bus pull-off, consistent with planned PennDOT improvements, will also improve access to the station.
- The crosswalk distance along the transit tunnel entrance has been decreased by about two feet in order to lessen the amount of time spent in the cartway.

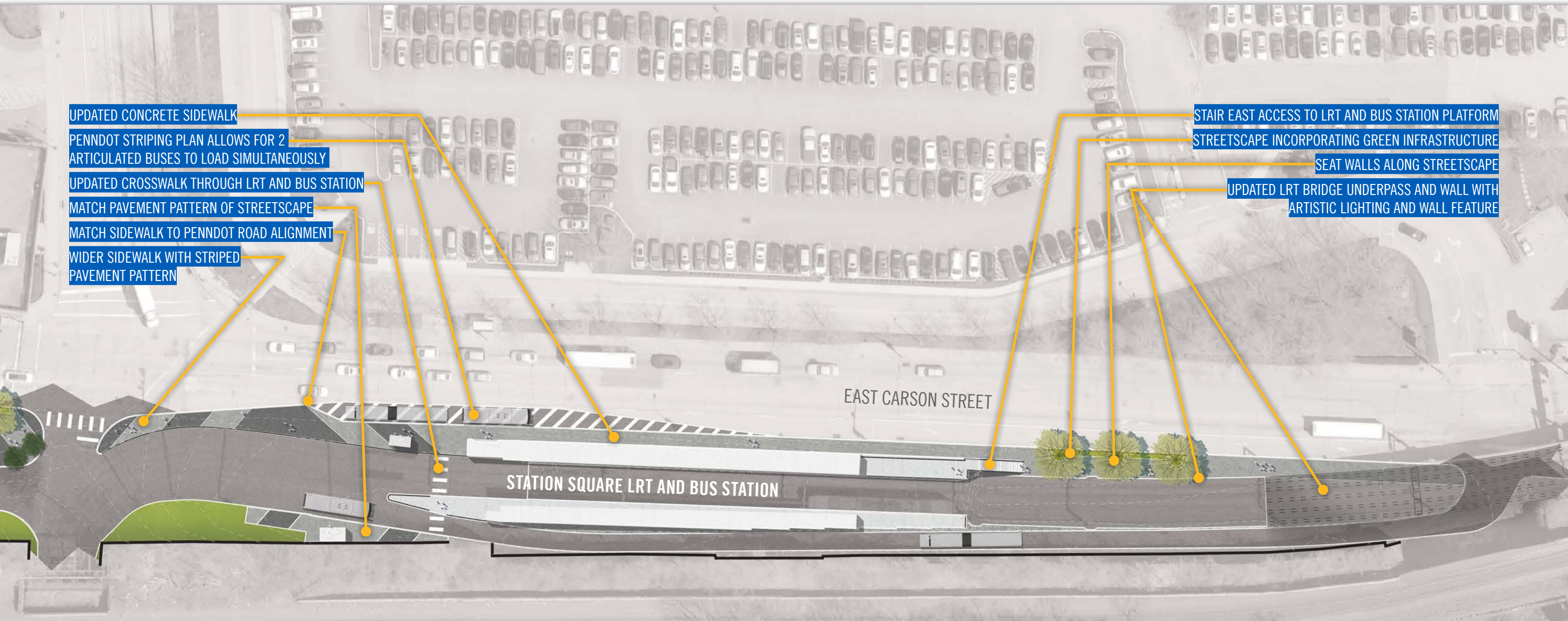

LRT STATION: SITE

OPPORTUNITIES FOR PUBLIC ART

The area which is located at the east end of the station presents an opportunity for streetscape enhancements since it includes property currently controlled by the Port Authority. In order to fill the void left by the elevated tracks, a screen system has been proposed; the screen could potentially be lit from behind to provide added safety and visual relief during the nighttime hours. Visual interest on the screening could come from graphic details or applying vegetation.

Since the wall which supports the light rail system is also imposing, the incorporation of public art is proposed. The concepts depicted on the following pages highlight the names of the light rail stations superimposed on the concrete wall using a heavy-duty vinyl adhesive to withstand extreme weather conditions.

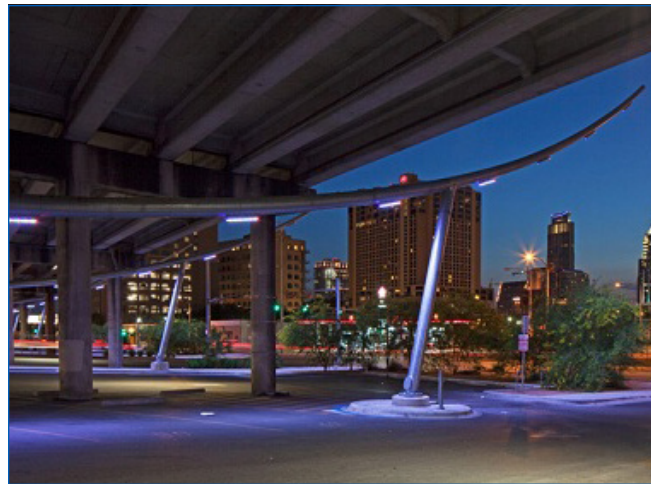

Examples of artistic design showing custom wall graphics and sculptural lighting displays for areas similar to the underpass near the intersection of East Carson Street and Arlington Avenue. Source: Breen Masciotra and Web Urbanist



Suggested improvements to the LRT underpass near the intersection of East Carson Street and Arlington Avenue include a decorative screen wall depicting the form of the Smithfield Bridge and vinyl graphic adhesive highlighting LRT stations.



Suggested improvements to the LRT underpass near the intersection of East Carson Street and Arlington Avenue include a vegetated screen wall vinyl graphic adhesive highlighting LRT stations.

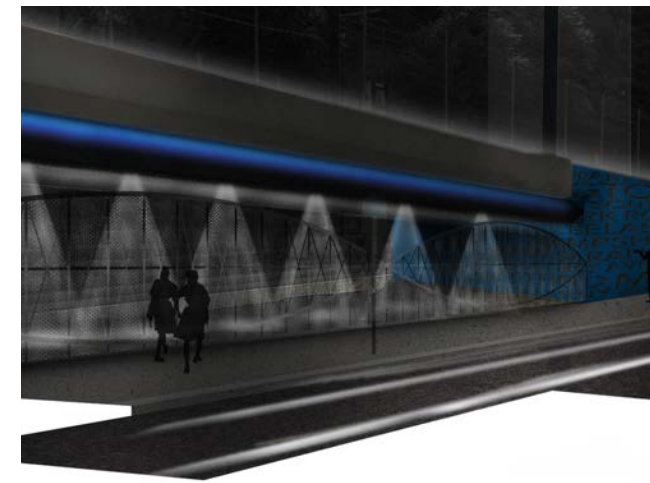

Suggested improvements to the underpass at night show spot lights highlighting the detail within the screen wall.

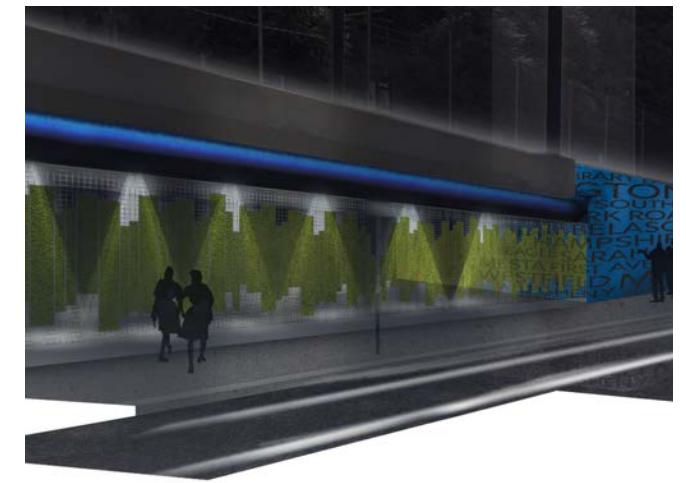

Suggested improvements to the underpass at night show spot lights highlighting the detail within the vegetated screen wall.

LRT STATION: STRUCTURE

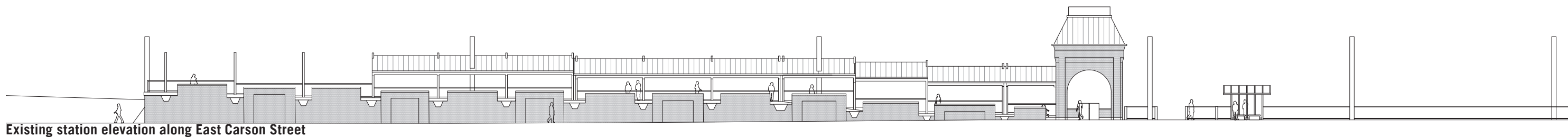

Existing station elevation along East Carson Street

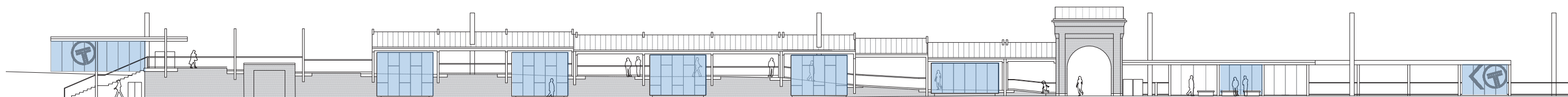

Conceptual station elevation along East Carson Street



Source: Composite of Google Streetview imagery



EAST ENTRY

A new entry to the outbound platform would improve access to the mixed-use properties to the east of the station along East Carson Street. Improvements to consider are:

- New entry canopy for shade and shelter
- New fare validation station
- Public art and station branding

STATION PLATFORM

Improvements to the station platform would make the light rail station more comfortable and inviting. Improvements to consider are:

- New back-lit textured panels to make the station feel lighter and coordinate station identity
- New seating in line with station design standards
- New branding and system information signage

WEST ENTRY

Improvements to the West Entry would make the station easier to use and understand. They include:

- Aligning station entry and interior crosswalk with the archway
- Relocating ticket vending machines

STATION ORIENTATION

The visual connection between the station and Smithfield Street should be enhanced by:

- Adding back-lit textured panels, the same as on the station platform, to clarify the connection between light rail, buses, and incline

LRT STATION: STRUCTURE

EAST ENTRY

When the station was originally conceived and constructed, it was intended to primarily serve Station Square and southern parts of Downtown. Today, a new mix of uses has emerged in South Side near the intersection of East Carson Street and Arlington Avenue. A supplementary entrance at the east end of the outbound platform would improve access and ease of use for riders coming from Downtown to the South Side and for riders going from the South Side to points in the South Hills.

This supplementary entrance could also be an opportunity for enhanced station branding. The canopy and back-lit textured panels should be of the same design as proposed at the other end of the station. The existing bulkhead access door would need to be relocated to the side of a new staircase.

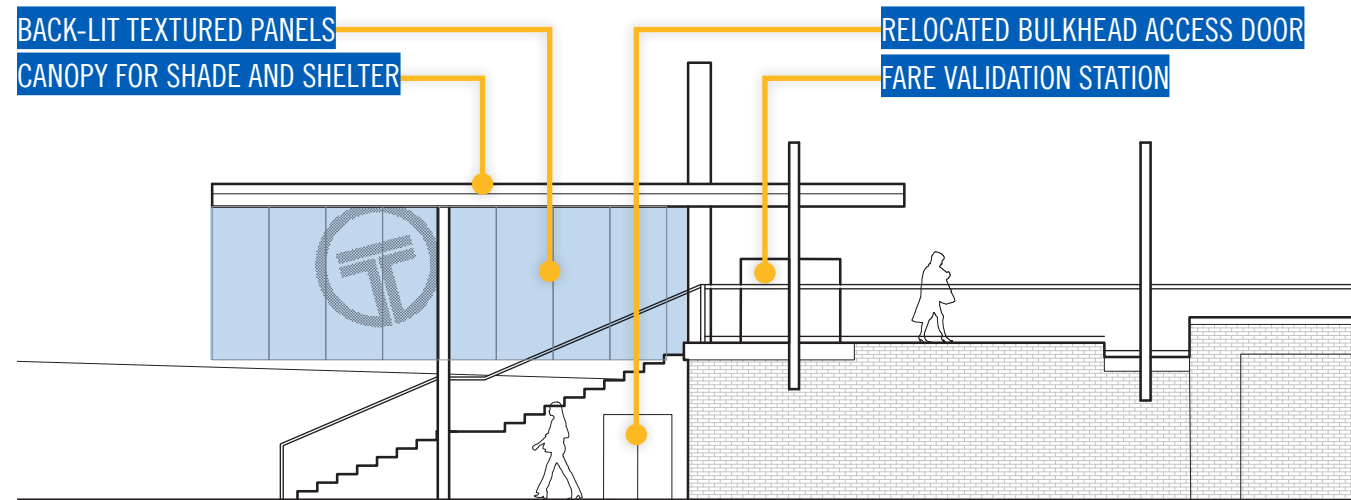

A conceptual elevation for a supplementary station entry at the east end of the outbound platform.



A view of the existing east end of Station Square transit center. There is a bulkhead that accesses electrical infrastructure as well as minimally effective station branding.

FACADE MATERIALS

The existing station uses red brick and structural members are painted dark red to match. The result is that the station's structure and configuration lack visual definition and appear monotone. To break down the visual scale of the station and make the platform feel lighter and more open, it is recommended that a new distinguishing facade material be added. Back-lit textured panels, such as perforated metal or fritted glass, can provide a wind break and visual interest without disrupting visibility of people on the station platform. The back-lighting can also serve as a wayfinding beacon for users during evening and nighttime, improving ease of use and feelings of security.

These textured panels should be utilized throughout the Station Square transit center area, including along the station platform, at the proposed east entry, at the revised west entry, near the incline station, and at area bus shelters. It is also recommended that structural members be painted white, as seen at East Liberty Station, to better disperse natural and electric lighting throughout the platform.



PERFORATED METAL

Source: el dorado inc

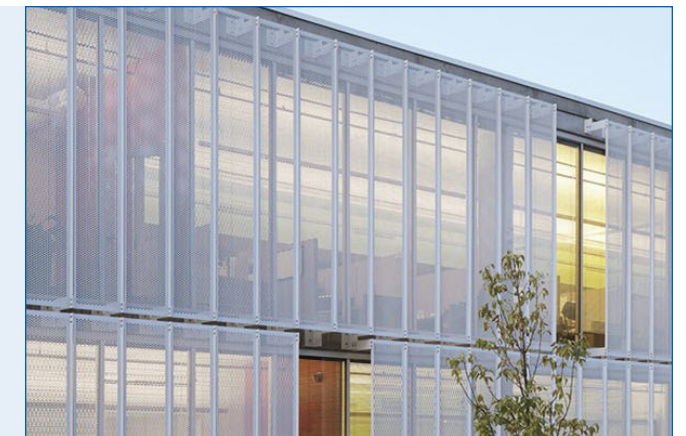

Source: inhabitat.com

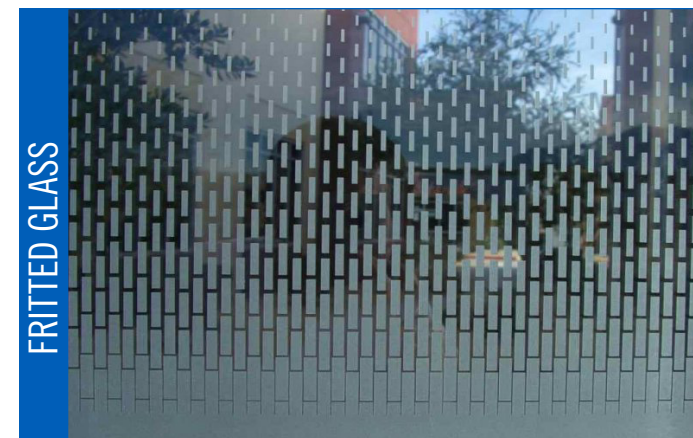

FRITTED GLASS

Source: dianliwenmi.com

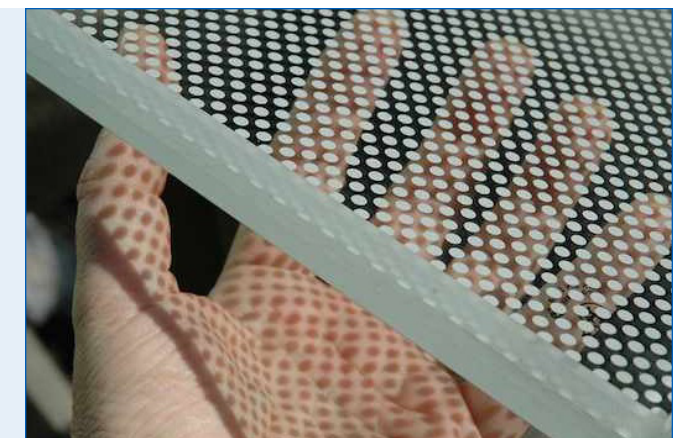

Source: The American Ceramic Society

LRT STATION: STRUCTURE

OUTBOUND PLATFORM

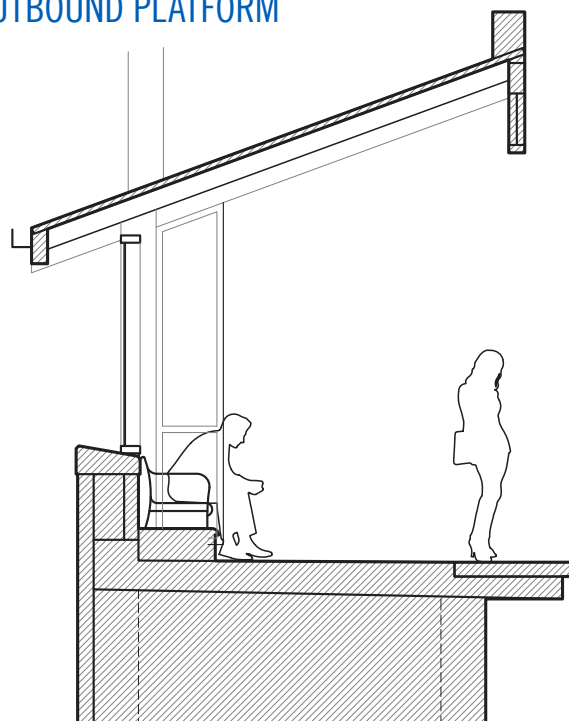

Existing section through the outbound station platform

To improve the station experience and the appearance of the station overall, several changes should be made to the outbound platform which has a facade along East Carson Street. The platform is sloped upward from west to east and the structure includes an alternating series of brick parapets. These parapets should be reduced to the level of the station platform, thus improving visibility of users on the platform and effectively widening the platform width.

To add definition to the station's appearance and to break down its visual scale, back-lit textured panels should be placed behind the benches at every other segment. Fritted glass or perforated metal paneling would improve the station's appearance on the street and back-lighting would enhance the user experience on the station platform.

New benches on the platform should be cast-in-place concrete with wood slats, as seen at East Liberty Station and recommended for Negley Station. Since the parapet wall would be removed, the new benches could be able to be set further back from the platform edge thus widening the platform.

The ceiling and structural members should be painted white to make the station feel lighter and more inviting by reflecting natural and electric light. The roof should be painted or replaced with either white or gray. LED lighting should replace existing fixtures and colored LED accent lighting could be used to enhance station branding efforts. Existing patterned glass panels on the interior roof edge should be removed.

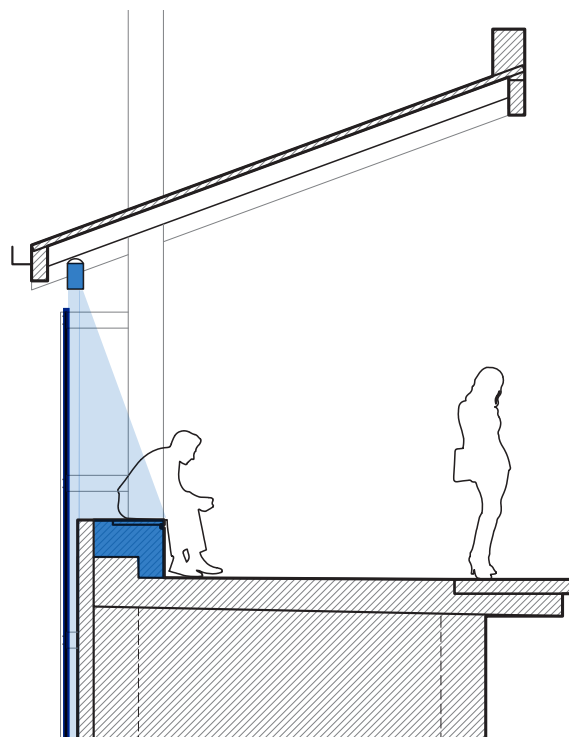

Conceptual section through the outbound station platform

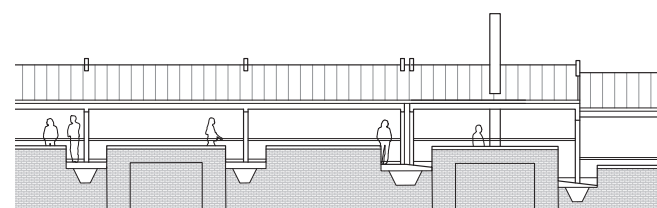

Existing station elevation along East Carson Street

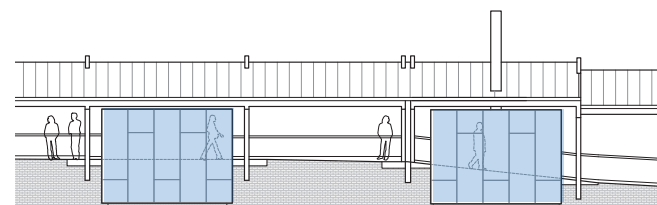

Conceptual station elevation along East Carson Street

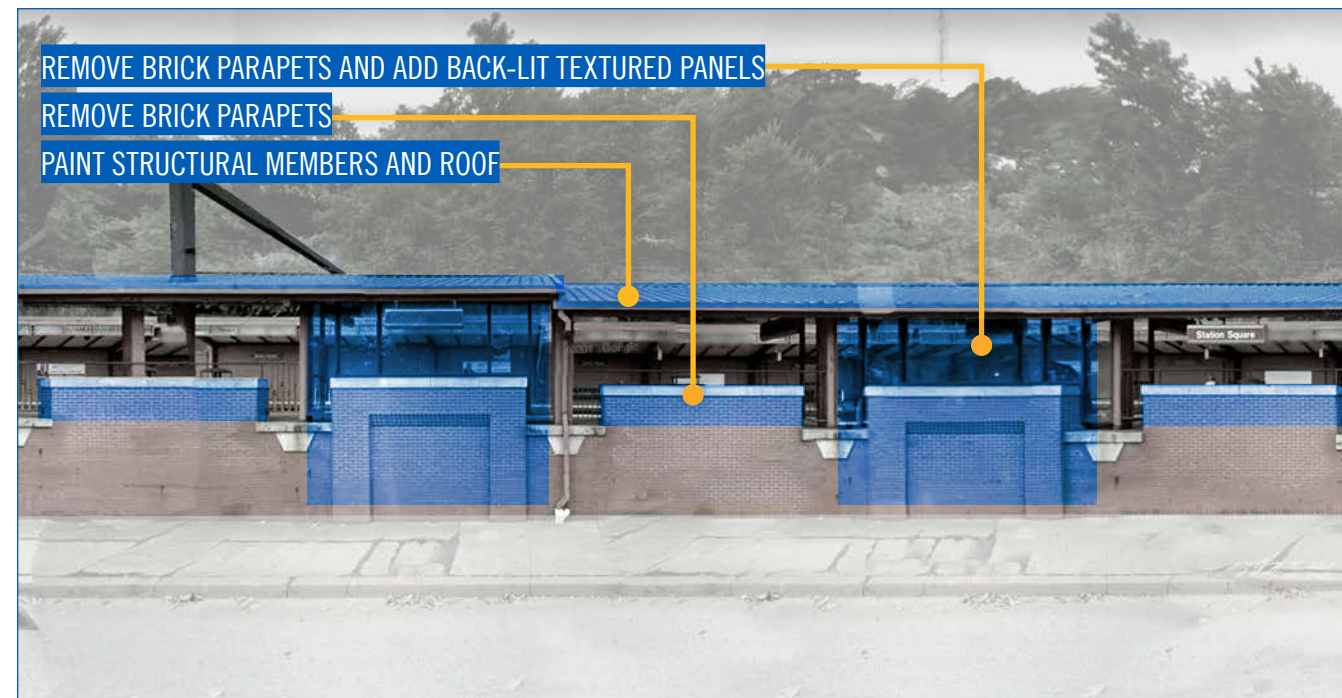

An elevation view of the outbound platform Station Square transit center along East Carson Street
Source: Composite of Google Streetview Imagery



An interior view of the outbound platform

LRT STATION: STRUCTURE

INBOUND PLATFORM

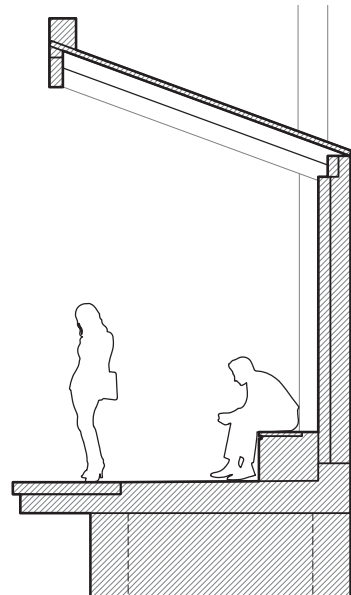

Existing section through the inbound platform

The existing inbound station platform is dark and the ceiling feels low. This side of the platform feels closed and monolithic compared to the outbound platform. Unifying the design language and allowing for more light can enhance the rider's experience.

A clerestory opening or window could open the wall up for views of the embankment and allow for natural light. It can also make the platform ceiling feel lighter by creating the illusion that it is "floating".

Back-lit fritted glass or perforated panels could help the inbound platform to appear to be a mirror of the outbound platform. This also offers the opportunity for integrated signage, branding, and advertising.

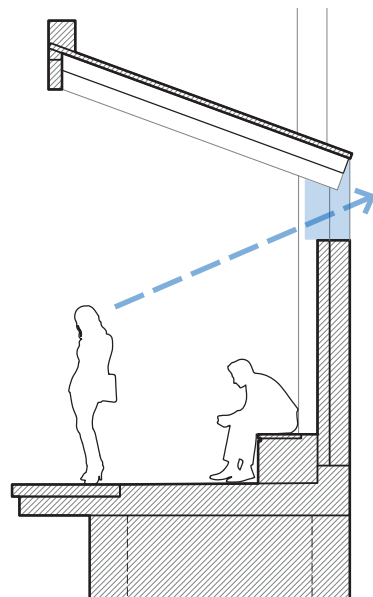

Conceptual section through the inbound platform showing a clerestory window

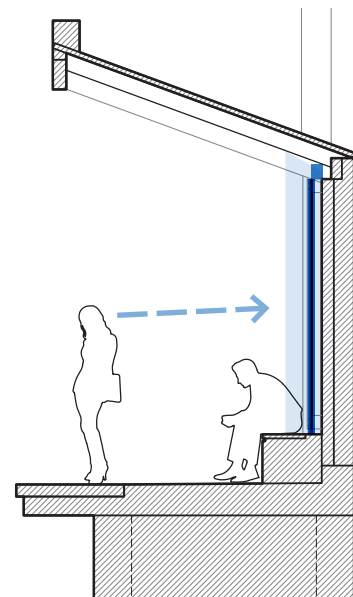

Conceptual section through the inbound platform showing a back-lit textured panel

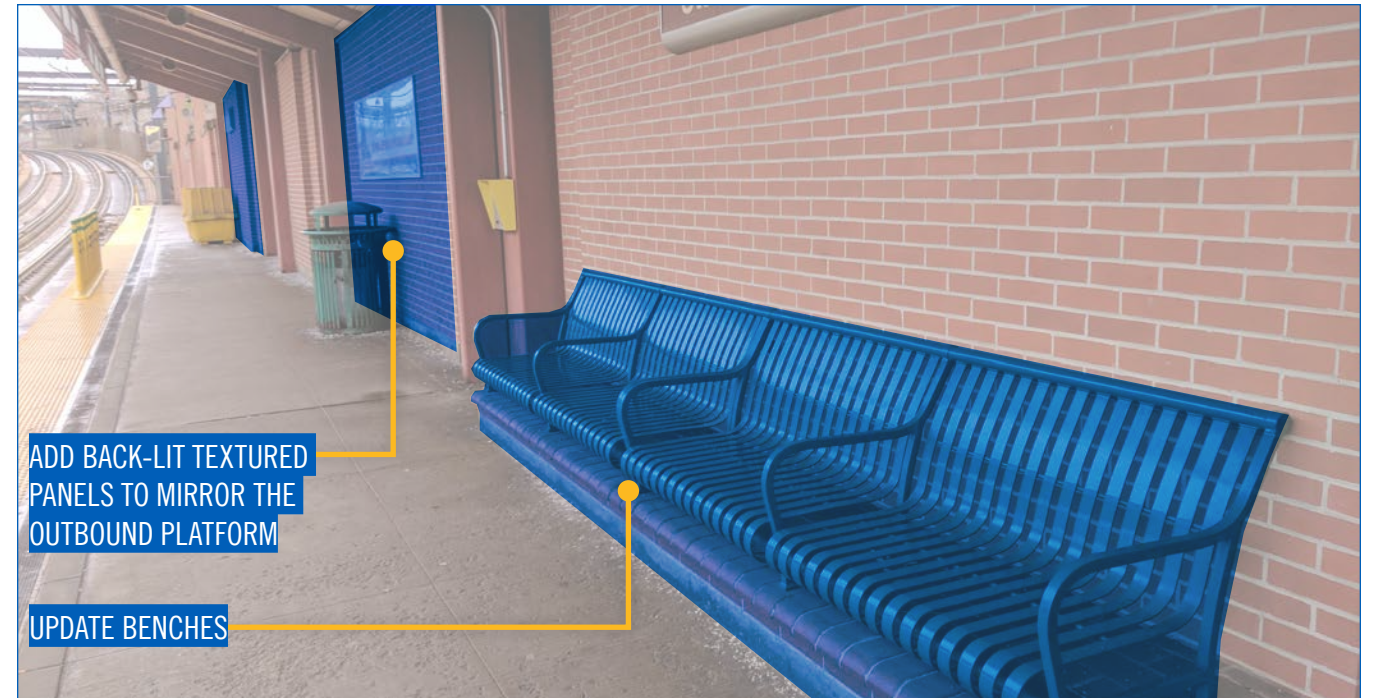

ADD BACK-LIT TEXTURED PANELS TO MIRROR THE OUTBOUND PLATFORM

UPDATE BENCHES

A view of the inbound platform looking east

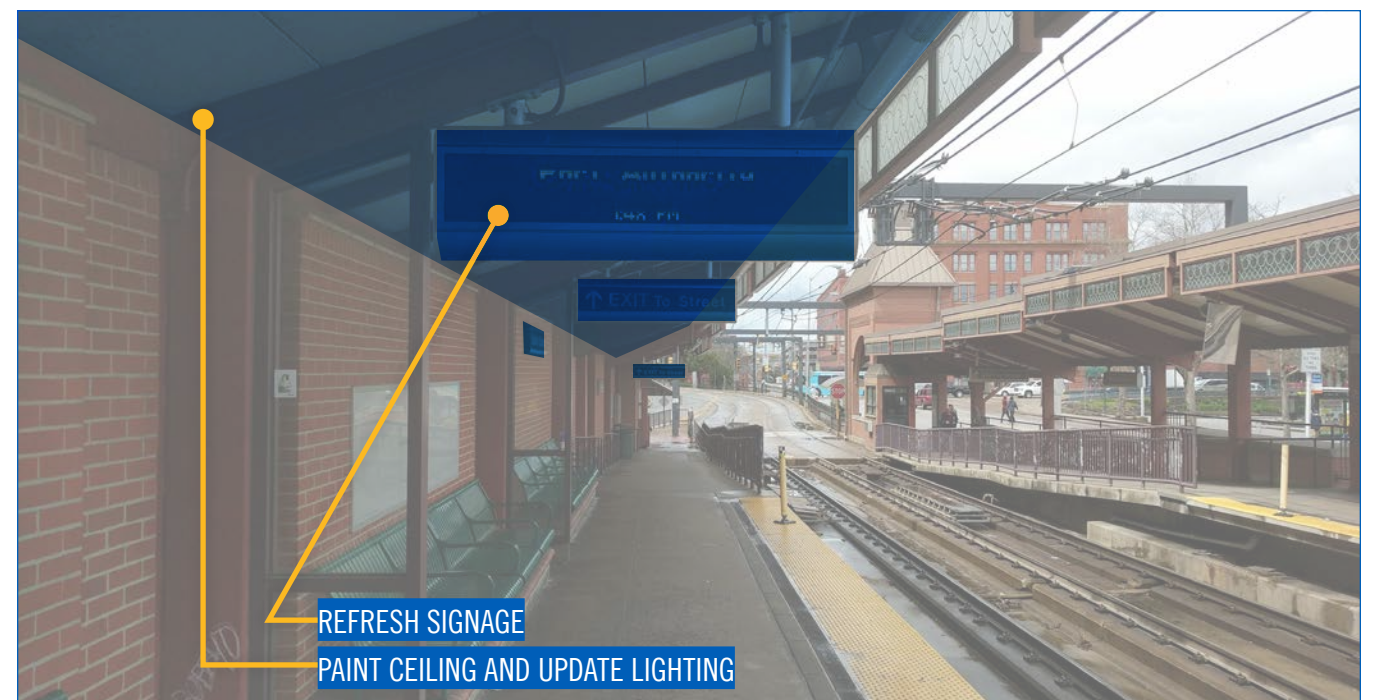

REFRESH SIGNAGE

PAINT CEILING AND UPDATE LIGHTING

A view of the inbound platform looking west

LRT STATION: STRUCTURE

WEST ENTRY

Entry to the platform is marked by a monumental arch but the actual entry is through a gap in the fence. This may be an artifact of the old streetcars which used a low level platform at the west end of the station, conflicting with a crosswalk where the arch is.

The proposal is to move the platform entry to the archway and to expand the East Carson Street bus stop. The existing crossing to the inbound South Busway stop remains; however, the use of that stop may benefit from operational review as it is redundant to an inbound stop on East Carson Street.

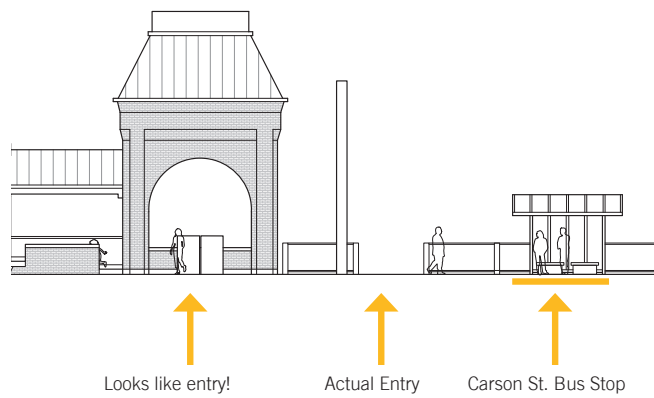

Existing elevation through Station Square transit center

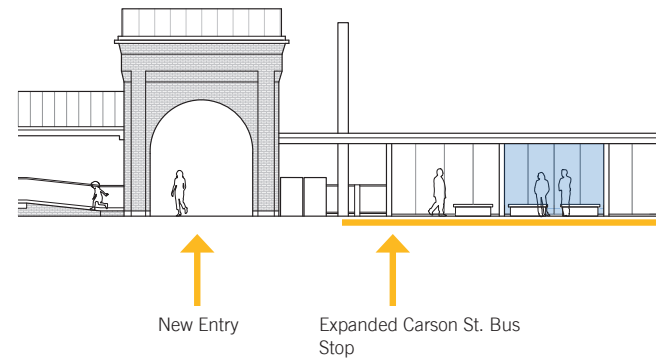

Conceptual elevation through Station Square transit center

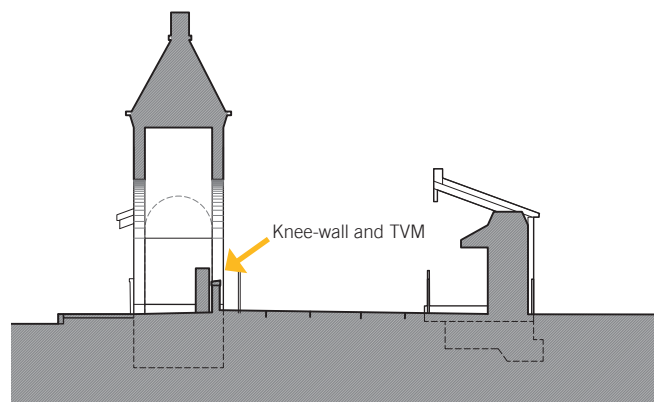

Existing section through Station Square transit center

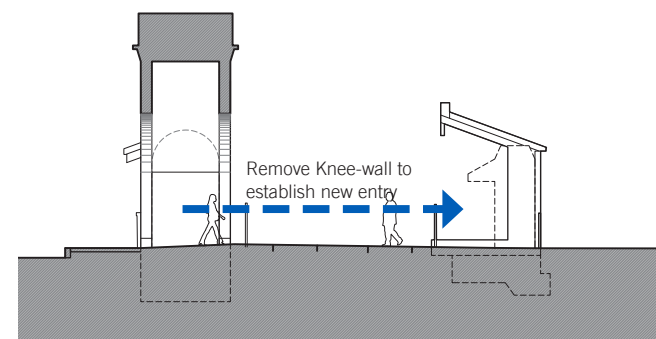

Conceptual section through Station Square transit center

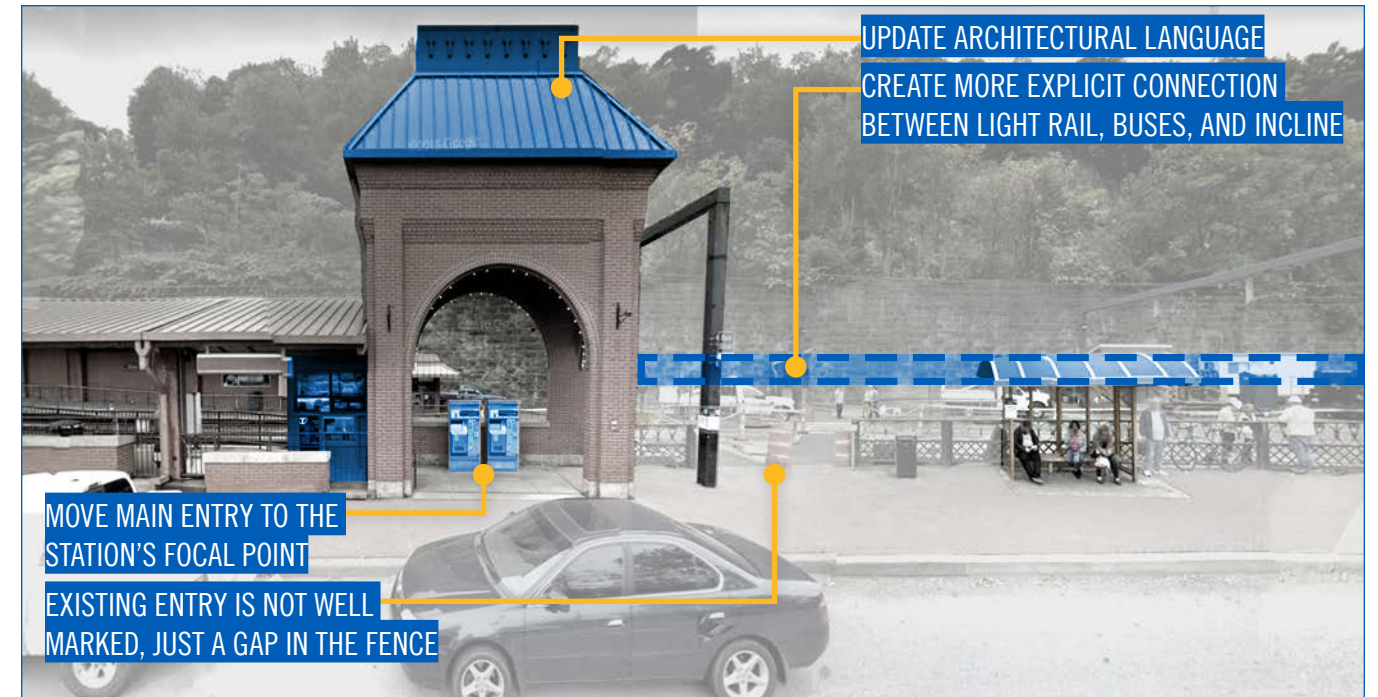

An elevation view of the outbound platform Station Square transit center along East Carson Street. Source: Composite of Google Streetview Imagery

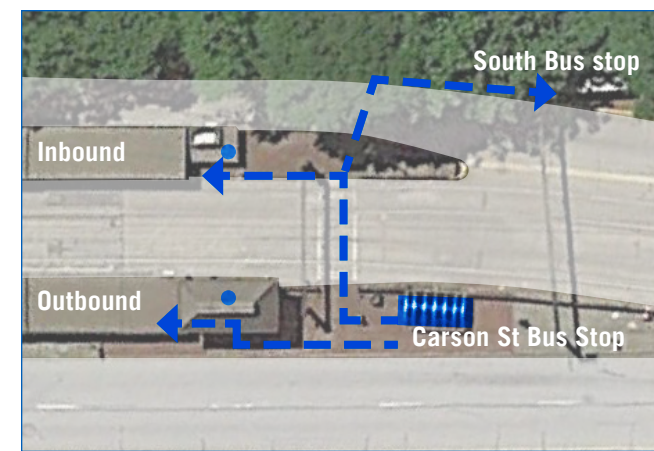

Existing user access to Station Square transit center

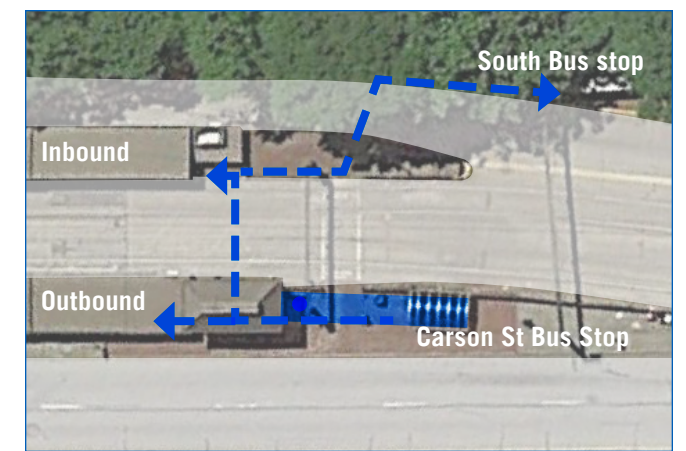

Conceptual user access to Station Square transit center

LRT STATION: STRUCTURE

WEST TOWER ENTRY

The existing west entry tower to the light rail station is a rectangular structure with arches on four sides and a trapezoidal roof. The tall, steeply sloped roof appears to be an homage to the original entry portals that existed on the Smithfield Street Bridge. The current configuration of the roof on the west entry tower is designed and detailed in a way that makes the transit center feel dated. It is not a faithful reproduction of the Smithfield Street Bridge portals and serves no practical purpose.

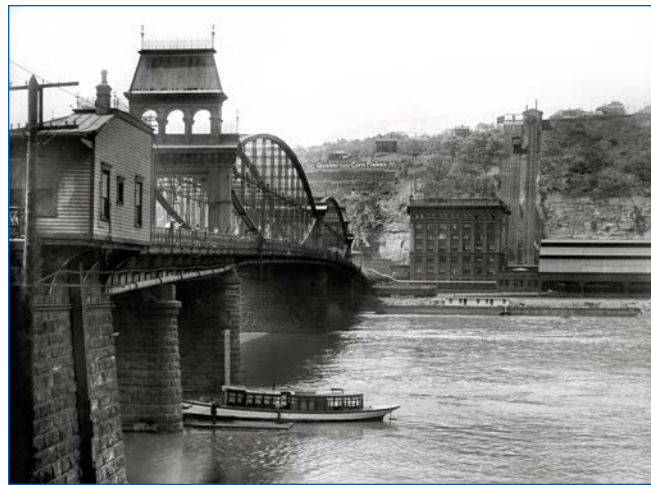

The entry portals for the Smithfield Street Bridge originally featured tall roof-like structures that helped the bridge to be seen from a distance.



The top of the entry portals were removed in 1911 when the bridge was widened. Source: Pittsburgh City Photographer Collection, University of Pittsburgh



An early photograph of the Smithfield Street Bridge showing an entry portal before it was widened in 1911. Source: Jones and Laughlin Steel Corporation Photographs, Historical Society of Western Pennsylvania

This project sketched a few alternative roofs for the tower that could be considered if and when the structure is replaced or refurbished. Improvements should build on other improvements to the station's identity by using similar materials. A back-lit roof structure could act as a beacon, making the station more visible and iconic for pedestrians.

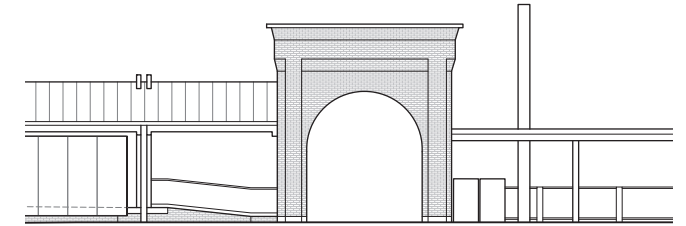

Conceptual elevation of the west entry tower showing the removal of the existing steeply-sloped trapezoidal roof

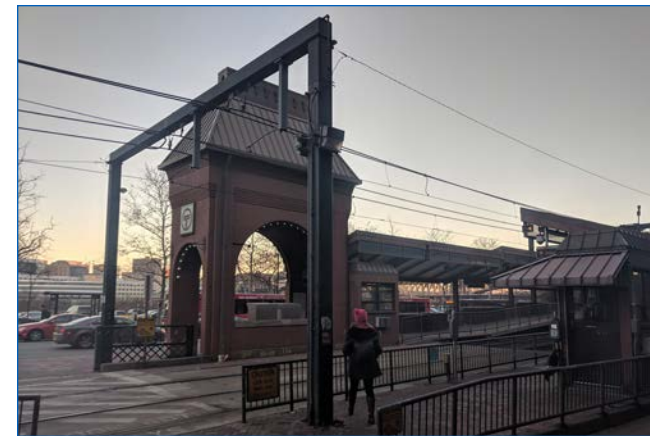

Station Square transit center's west entry features a tower with a steeply-sloped trapezoidal roof

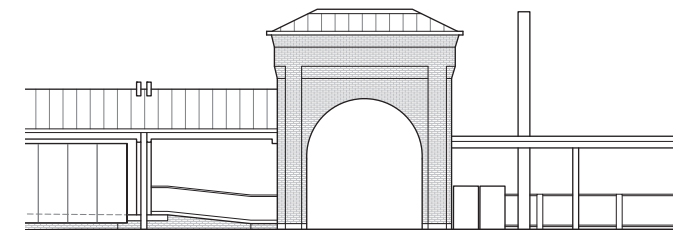

Conceptual elevation of the west entry tower showing replacement of the existing roof with a reduced scale hip roof

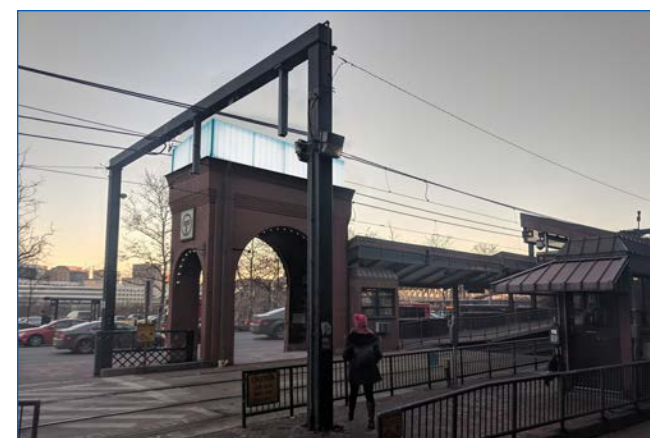

A rendering showing what the west entry tower might look like with back-lit textured panels to act as a wayfinding beacon for the light rail station

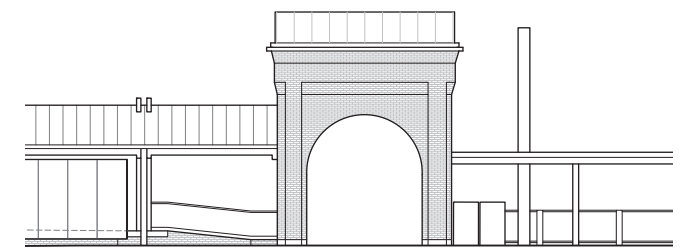

Conceptual elevation of the west entry tower showing replacement of the existing roof with back-lit textured panels

4.



IMPLEMENTATION STRATEGY

4.1 IMPLEMENTATION

The findings of the previous stages have informed the following implementation recommendations which address the Port Authority's various roles in shepherding the ideas in this plan to completion. The recommendations address issues related to funding, the roles of stakeholders, and policy recommendations.

Transit-oriented development is already occurring adjacent to the Station Square transit center and the Port Authority continues to advocate for and enable high-quality TOD. The agency prepared for TOD in the area by establishing TOD Design Guidelines, organizing and leading the necessary agencies and groups in order to educate and build relationships, informing the public, and by developing plans that are market-ready and well-integrated with necessary infrastructure improvements.

The consultant team prepared conceptual plans for strategic areas located within the walkshed of the Station Square transit center. This chapter is organized according to the Port Authority's role in implementation.

1: COLLABORATE

This role encompasses proposed projects and strategies that the Port Authority can influence through strategic collaborations.

Projects include:

- Transit-oriented development at the Trammell Crow site
- Improved streetscapes (along East and West Carson Streets)
- Improved gateways (at the intersection of Smithfield Street and Carson Street)

2: DESIGN

This role reflects proposed projects and implementation strategies that are linked to property controlled by the Port Authority. Projects include:

- Station improvements
- Enhanced access to the station
- A new access road at the Monongahela Incline Lower Station site



Concept plaza design for the area next to the Monongahela Incline Lower Station creating and public space extension to the station.

Potential Early Catalytic Projects
0-2 years

Port Authority Station Improvements

Action Items:

- Continue refinement of station conceptual design.
- Monongahela Incline Lower Station improvements, including plaza area, sidewalk, corner signage
- LRT and bus station improvements, including outbound and inbound platform enhancements, east entry stairwell, identity signage, reconfigured west entry
- Coordinate with PAAC TOD advisory committee .
- Allocate capital ifunding for priority improvements.

Ongoing Port Authority TOD Efforts

Action Items:

- Explore TOD-firendly zoning for the station area.
- Investigate Tax Increment Financing (TIF) or TRID for TOD.
- Continue to support TOD at Trammell Crow site.

Improvements along East and West Carson Streets (south side of street)

Action Items:

- Design streetscape improvements and incorporate with station area conceptual plans.

Monongahela Incline Lower Station Access Road

Action Items:

- Continue exploration of access road design.
- Allocate capital funding for roadway.

Medium Term Projects
2-5 years

Public Realm Improvements along East and West Carson Streets (north side of street)

Action Items:

- Work with City of Pittsburgh and private property owners to incorporate green infrastructure along East and West Carson Streets at the street curb.

Long Term Strategic Initiatives
5+ years

Other Proposed Access Improvements – East Carson Street and Arlington Avenue, West Carson Street

Action Items:

- Work with PennDOT for roadway improvements, including: relocated stop bar, dedicated left turn lane.

Other Proposed Access Improvements – West Carson Street

- Work with PennDOT to analyze the addition of a crosswalk across West Carson Street near the Wabash Tunnel.

4.2 COLLABORATE

IMPROVEMENTS ALONG THE SOUTH SIDE OF EAST AND WEST CARSON STREETS

Public realm improvements proposed for East and West Carson Streets (along the south side of the road) represent short-term (0 to 2 years) priority projects. Design solutions include the introduction of green infrastructure along the right-of-way in order to potentially capture street run-off, the addition of street trees to buffer pedestrians from the roadway, the introduction of public art, and the development of expanded sidewalks and realigned crosswalks. Since these public realm improvements are located directly adjacent to Port Authority property, implementation of these projects should occur in conjunction with planned station area improvements.

The safety improvements proposed by PennDOT for East Carson Street are planned for construction over the next few years and the Port Authority should continue to engage with PennDOT to ensure that multimodal solutions are implemented at and near transit stations and platforms.

PUBLIC REALM IMPROVEMENTS ALONG THE NORTH SIDE OF EAST AND WEST CARSON STREETS

Public realm improvements proposed for East and West Carson Streets (along the north side of the road) represent mid-term (2 to 5 years) priority projects. Improvements proposed for the north side of West Carson Street include an improved sidewalk connection along the Station Square property, including a potential link to a crosswalk from the Monongahela Incline Lower Station. The Port Authority should continue to work with Forest City as part of their ongoing efforts to manage and lease new space at the Station Square development.

The Port Authority owns a portion of the right-of-way that runs along the north side of East Carson Street (at the existing bus shelter location). Since this access way is important for both the new TOD and the Station Square transit center, the Port Authority should continue to work with Trammell Crow and the city to encourage an improved streetscape that incorporates street trees and a sidewalk that is buffered from East Carson Street. It is also suggested that the curb radius at the northeast and northwest corner of East Carson Street and Smithfield Street be increased since the existing right turn lane appears to have sufficient space for an expanded curb.

OTHER PROPOSED ACCESS IMPROVEMENTS – EAST CARSON STREET AND ARLINGTON AVENUE

The intersection at East Carson Street and Arlington Avenue is critical as an access point for the TOD occurring adjacent to Station Square, and also as a path for those traveling to Station Square from the South Side. The existing intersection is confusing and an improvement proposed by PennDOT (a new crosswalk and revised signal phasing) will alleviate some safety concerns. Additional initiatives that would also address safety concerns include the following:

- A relocated stop bar that is pushed back slightly to accommodate buses making a left turn from the South Busway ramp
- A dedicated left turn lane from East Carson Street to East Station Square Drive

TRANSIT-ORIENTED DEVELOPMENT AT THE NORTHEAST CORNER OF SMITHFIELD STREET AND EAST CARSON STREET

The Port Authority should continue conversations with Trammell Crow, the developer of the Glasshouse, to ensure that multi-modal connections between the TOD and transit center are enhanced. As new phases of the project are developed in the future, and pedestrian traffic in the area grows, these connections will become increasingly important.

The Port Authority should also continue to work with Trammell Crow, Allegheny County, the Urban Redevelopment Authority, and the City of Pittsburgh to consider formation of a Transit Revitalization Investment District (TRID) to help finance infrastructure improvements associated with ongoing TOD adjacent to the station area. A TRID is similar to Tax Increment Financing (TIF) in that it proposes to promote economic development and foster public-private partnerships through applying incremental growth in property taxes to related infrastructure improvements.

OTHER PROPOSED ACCESS IMPROVEMENTS – WEST CARSON STREET

Since West Carson Street also functions as a major access point to the station area, additional improvements are proposed to address enhanced pedestrian access. These improvements include the addition of a crosswalk across West Carson Street near the Wabash tunnel entrance, providing direct access to Station Square upon exiting the incline station.

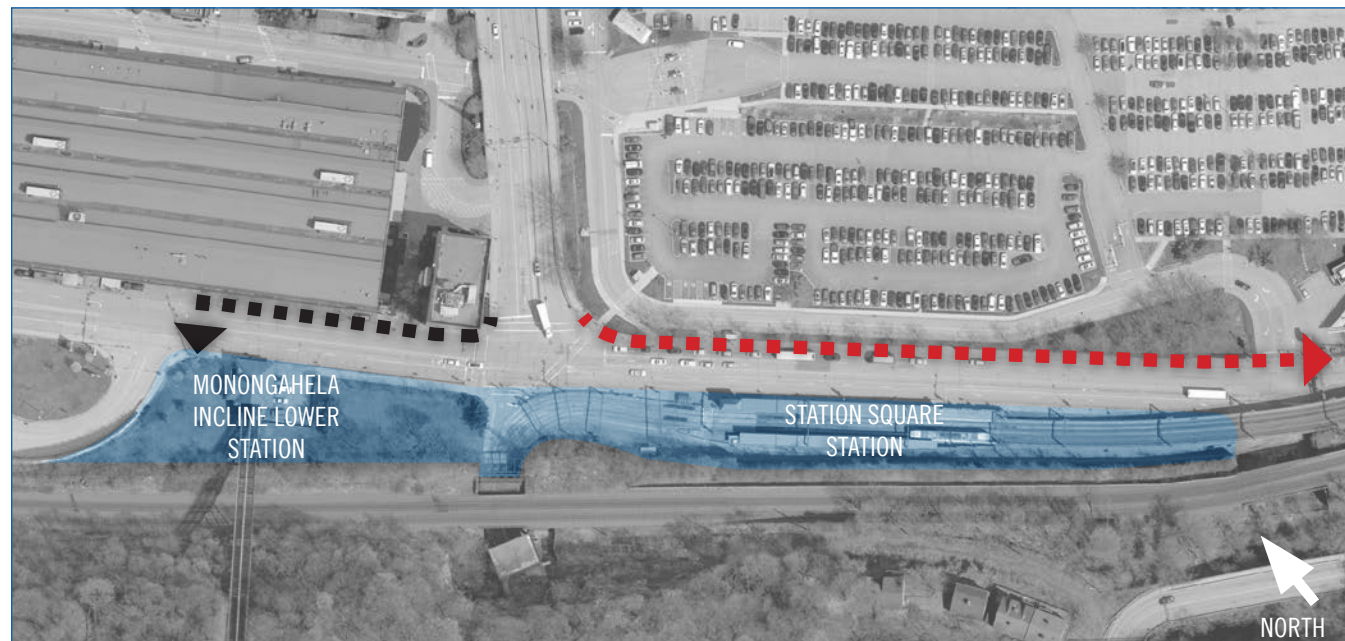

■ Station Square transit center
 - - - - - West Carson Street public realm improvements
- - - - - East Carson Street public realm improvements



Green infrastructure improvement to streetscapes using vegetation to buffer pedestrians from traffic
 Source: njfuture.org

4.3 DESIGN

STATION AREA IMPROVEMENTS

The station area improvements proposed in this plan will continue to be vetted by the Port Authority. As part of this process, subject to budgeting approvals and limitations, the Port Authority will continue to prioritize and potentially fund station design projects through future phases. Recommended ideas which are central to the station area design include the following:

- Creation of a sense of place when arriving at the Station Square transit center. A cohesive design has been proposed between the two stations through pavement patterns, signage, and site-specific elements which are able to tie the historical character of the Monongahela Incline Lower Station to a modernized design for the Station Square LRT and bus station.
- Proposed entry reconfiguration to the Monongahela Incline Lower Station with construction of a wider main door, additional secondary doors, and one-level sidewalk frontage with the pedestrian rail pulled back to the curb line
- Improvements to safety for all pedestrians through proposed widening of sidewalks, clearly marked crosswalks, and a vegetative buffer along Carson Street.
- Construction of a new access road along the rear of the Monongahela Incline Lower Station to allow for maintenance equipment, incline shuttle access, and staff parking
- Development of a new outdoor exhibit and plaza adjacent to the Monongahela Incline Lower Station, which provides additional station capacity and allows visitors to explore views of the incline as well as experience the history of the station
- Construction of a new ADA access ramp through improved green space, providing a connection from the station to the proposed access road and shuttle stop
- Creation of a designated bus lane for loading and unloading in the south curbside lane on East Carson Street, as planned in PennDOT's improvements
- Improvements to the Station Square LRT station platforms should include increased openness and visibility, updated architectural language, and structural connection between the LRT station and bus stop
- Construction of an east entrance onto the outbound light rail platform
- Inclusion of public art at the underpass of the LRT bridge, east of the station, to create a welcoming gateway approaching the station area from the east

COST ESTIMATE

Preliminary cost estimates for the projects enumerated here include the following (note that the cost estimates are for construction only and do not include costs for demolition, soft costs, and other agency coordination). A 15% contingency is included within the site and civil estimate. It should be noted that these are cost estimates only and that more detailed estimates would be derived once the plans are advanced beyond conceptual design.

Site/Civil: Incline side	\$600k - \$650k
Site/Civil: LRT side	\$500k - \$550k
Total Site/Civil:	\$1.1M - \$1.2M

Outbound platform facade panels, benches, lighting:	\$200k - \$250k
Inbound platform facade panels, benches, lighting:	\$150k - \$200k
Proposed east entry stairwell:	\$275k - \$325k
Reconfigured west entry, bus shelter, station identity signage:	\$375k - \$425k
Total for Station Square LRT and bus station:	\$1M - \$1.25M

Monongahela Incline Lower Station Improvements:	\$150k - \$200k
Two Lane Access Road:	\$1.1M - \$1.25M
One Lane Access Road:	\$850k - \$1M



Monongahela Incline Lower Station Conceptual Plan



Station Square Station Conceptual Plan

A.



APPENDICES

A.1 TRANSPORTATION PLANNING

PEDESTRIAN AND BICYCLE SAFETY EVALUATION

Similar to FHWA's formal Road Safety Audit (RSA) program, the TOD team performed a safety assessment within the Station Square Station's half mile walkshed. The team reviewed crash data for all intersections within the past five years of available data (2011 – 2015) to determine if there were instances of crash clusters, defined as five crashes within a 12 month period with similar causation factors. Additionally, the team performed a field visit of these intersections in March of 2017 to observe pedestrian safety hazards throughout the walkshed. Pedestrians that feel safer walking to transit stations are more likely to use them, so this report identifies opportunities to improve pedestrian safety. Recommendations for improvements within Port Authority-owned property have been incorporated into the station's redesign in this report. Recommendations beyond the station area itself are not intended to be implemented for the station improvement project, but are offered for consideration for incorporation when other projects are planned within the station's walkshed (by city and state agencies, private developers, utilities, etc.).

PennDOT performed a formal Road Safety Audit along East Carson Street starting at Smithfield Street and extending east into the South Side and is developing safety improvements based on the findings. These safety improvements are scheduled to be completed in 2019. The project team has coordinated with PennDOT through the project and supports most of the findings, though may offer additional improvements for consideration.

Crash Data Review

The project team requested reportable and available non-reportable crash records from the Pennsylvania Department of Transportation for the last five years of available crash data, from 2011 through 2015 (inclusive). Reportable crashes are defined as crashes involving injury (an ambulance) and/or towing. Minor crashes, such as low speed rear-ends and broken mirrors, or pedestrian crashes in which pedestrians refused treatment, are not reportable crashes and are not reflected by the crash data analysis. Crash data was requested along Carson Street, Smithfield Street, and Arlington Avenue, which included at the following intersections:

Carson Street

- Commerce Drive
- Wabash Tunnel
- Smithfield Street
- Arlington Avenue and Station Square Drive
- South First Street
- South Second Street
- South Third Street
- Terminal Way
- South Fifth Street

Smithfield Street

- Carson Street
- Fort Pitt Boulevard

Arlington Avenue

- Carson Street
- Sycamore Street
- P. J. McArdle Roadway

All roads within the study area experienced reportable crashes.

During the study period, there were a total of 146 crashes within the study area, 14 of which (10 percent) involved pedestrians. Almost a third (35 percent) of crashes were angle crashes and a third (32 percent) were rear-end crashes. Driver actions that contributed to the crashes were 16 percent turning improperly or carelessly, 14 percent driving distractedly, 6 percent affected by a physical condition, 4 percent driving too fast for conditions, 4 percent tailgating, 3 percent speeding, 3 percent proceeding without clearance, 3 percent red light running, 1 percent failing to respond to traffic control devices, and the remainder other improper driving or unknown actions. There were two fatalities. Once occurred in which the driver was impacted by a physical condition and struck a pedestrian and the other occurred when the driver struck a fixed object.

[Figure 1.1] Summary of Intersection Crash Data provides a summary of crash data by intersection or roadway segment, ranked by crash frequency and then severity. The table describes the most common contributing driver action and the most common collision type. Note that some crashes have multiple contributing driver actions and some actions, collision types, and severity levels are unknown.

Intersection	Number of Crashes Veh (Ped)	Most Common Driver Action (%)	Most Common Collision Type (%)	Fatality, Moderate or Major Injury (%)
E/W Carson St & Smithfield St	23 (3)	Improper/Careless Turn (33%)	Angle (52%)	1 (4%)
E Carson St & Arlington Ave / Station Square Dr	16 (3)	Improper/Careless Turn (22%)	Angle (50%)	1 (6%)
Smithfield St & Ft Pitt Blvd	10 (2)	Other Improper Driving (33%)	Angle (50%)	0 (0%)
W Carson St & Commerce Dr	10 (1)	Distracted Driver (18%)	Rear-end (60%)	0 (0%)
Arlington Ave & McArdle Rdwy	10 (0)	Affected by a Physical Condition, Other Improper Driving (tie) (20%)	Angle (40%)	0 (0%)
W Carson St & Wabash Tunnel	9 (0)	Improper/Careless Turn, Other Improper Driving (tie) (33%)	Rear-end (56%)	0 (0%)
Smithfield St from Carson St to Ft Pitt Blvd	9 (0)	Other Improper Driving (40%)	Rear-end (78%)	0 (0%)
Arlington Ave & Sycamore St	8 (0)	Proceeding without Clearance (25%)	Angle (63%)	1 (13%)
E Carson St & S 2nd St	8 (0)	Other Improper Driving (38%)	Angle (63%)	1 (13%)
E Carson St from Smithfield St to Arlington Ave	7 (4)	No Contributing Action (50%)	Pedestrian (57%)	0 (0%)
E Carson from Terminal Way to S 5th St	7 (1)	No Contributing Action (29%)	Rear-end (50%)	0 (0%)
E Carson St & 1st St	6 (0)	Distracted Driver (43%)	Rear-end (67%)	0 (0%)
E Carson St from 1st St to 2nd St	5 (0)	Other Improper Driving, No Contributing Action (tie) (20%)	Hit Fixed Object, Same Direction Sideswipe (tie) (40%)	0 (0%)
E Carson St from Arlington Ave to S 1st St	4 (0)	Other Improper Driving (50%)	Rear-end (75%)	0 (0%)
E Carson St from S 3rd St to Terminal Way	4 (0)	Distracted Driver (50%)	Angle, Head-on, Rear-end, Same Direction Sideswipe (tie) (25%)	1 (25%)
E Carson St & S 3rd St	3 (0)	Improper/Careless Turn (50%)	Angle (67%)	0 (0%)
E Carson St & Terminal Way	3 (0)	Distracted Driver, Tailgating, Other Improper Driving (tie) (33%)	Rear-end (100%)	0 (0%)
E Carson St & S 5th St	3 (0)	Distracted Driver (67%)	Rear-end (100%)	0 (0%)
E Carson St from S 2nd St to S 3rd St	1 (0)	Other Improper Driving (100%)	Angle (100%)	0 (0%)

[Figure 1.1] Summary of Intersection Crash Data

TRANSPORTATION PLANNING

Refer to **[Figure 1.2] Intersection Crash Occurrences (2011 – 2015)** for graphical summary of crashes at each location.

The crash data determined one potential crash cluster. At the intersection of Carson Street and Smithfield Street, there were 12 month periods with five angle crashes caused by improper or careless turns. This intersection operates at a failing level of service in the afternoon peak period, with much congestion. The eastbound Carson Street left lane has a shared left/through movement. The speed limit on Carson Street is 35 mph.

Over 70 percent (10 of 14) pedestrian crashes occurred in the one-block area along Carson Street from the intersections of Smithfield Street and Arlington Avenue / Station Square Drive (inclusive), on average two per year. The remaining crashes occurred on East Carson Street near Terminal Way where there happens to be an in-street bus stop, on West Carson Street at Commerce Drive which has a missing crosswalk and discontinuous pedestrian connection to Station Square, and on Smithfield Street at Fort Pitt Boulevard where there is a long, pre-timed signal phase, high traffic volumes, and sidewalk furniture that blocks visibility.

Reviewing crash data based on crash occurrences alone can be misleading, since busier roads generally experience more crashes. Adjusting for traffic volume, intersection crash rates were calculated using the following formula to give an intersection crash rate (R(i)) per million entering vehicles (MEV):

$$R(i) = (\text{Number of Crashes} \times 1,000,000) / (365 \text{ days} \times 5 \text{ years} \times \text{ADT})$$

PennDOT conducts average daily traffic volume (ADT) counts for state-owned highways and higher volume municipal roads.

East Carson Street (SR 0837) has the highest traffic volume with an average daily traffic (ADT) of 17,141 vehicles per day. Smithfield Street (SR 3027) has the second highest ADT of 12,816. West Carson Street's ADT is 11,418, Fort Pitt Boulevard's ADT is 9,283, McArdle Roadway's ADT is 8,854, Arlington Avenue's ADT is 8,146, and Sycamore Street's ADT is 3,508. The **[Figure 1.3] Available Intersection Crash Rate** table that follows summarizes the crash rate for intersections with available traffic data.

The intersection of Carson Street and Smithfield Street had the highest crash rate of 0.61 MEV. All Monongahela Incline riders and almost all Station Square LRT Station riders must walk through this intersection. The intersection of Arlington Avenue and McArdle Roadway had the second highest crash rate of 0.51 MEV, though fewer pedestrians use it. This shows that the roadway area around the Station Square station area has the highest number of intersection crashes in the walkshed.

In addition to crashes at intersections, crashes along roadway segments were studied. Using PennDOT's traffic volume data, the following roadway segment crash rates were calculated using the following formula to give a roadway segment crash rate (R) per million vehicle miles traveled:

$$R = (\text{Number of Crashes} \times 1,000,000) / (365 \text{ days} \times 5 \text{ years} \times \text{ADT} \times \text{Length of Segment in Miles})$$

The **[Figure 1.4] Available Roadway Segment Crash Rate** table that follows summarizes the crash rate for roadway segments with available traffic data, inclusive of crashes occurring intersections at the end of each segment.

Intersection	ADT	Number of Crashes	Crash Rate (MEV)
Carson St & Smithfield St	20,506	23	0.61
Carson St & Arlington Ave	25,288	16	0.35
Arlington Ave & McArdle Rdwy	17,000	10	0.51
Smithfield St & Ft Pitt Blvd	22,099	10	0.32
Arlington Ave & Sycamore St	10,707	8	0.20

[Figure 1.3] Available Intersection Crash Rates

Roadway Segment	ADT	Length (mi)	Number of Crashes	Crash Rate (MEV)
E Carson St from S 5th St to Arlington Ave (Inclusive)	17,142	0.39	60	4.96
E Carson St from Arlington Ave to Smithfield St (Inclusive)	17,142	0.17	46	8.77
W Carson St from Smithfield St to Commerce Dr (Inclusive)	11,418	0.21	42	9.50
Smithfield St from Carson St to Ft Pitt Blvd (Inclusive)	12,816	0.37	42	4.86
Arlington Ave from E Carson St to McArdle Rdwy (Inclusive)	8,146	0.25	34	9.29

[Figure 1.4] Available Roadway Crash Rates

INTERSECTION CRASH OCCURRENCES

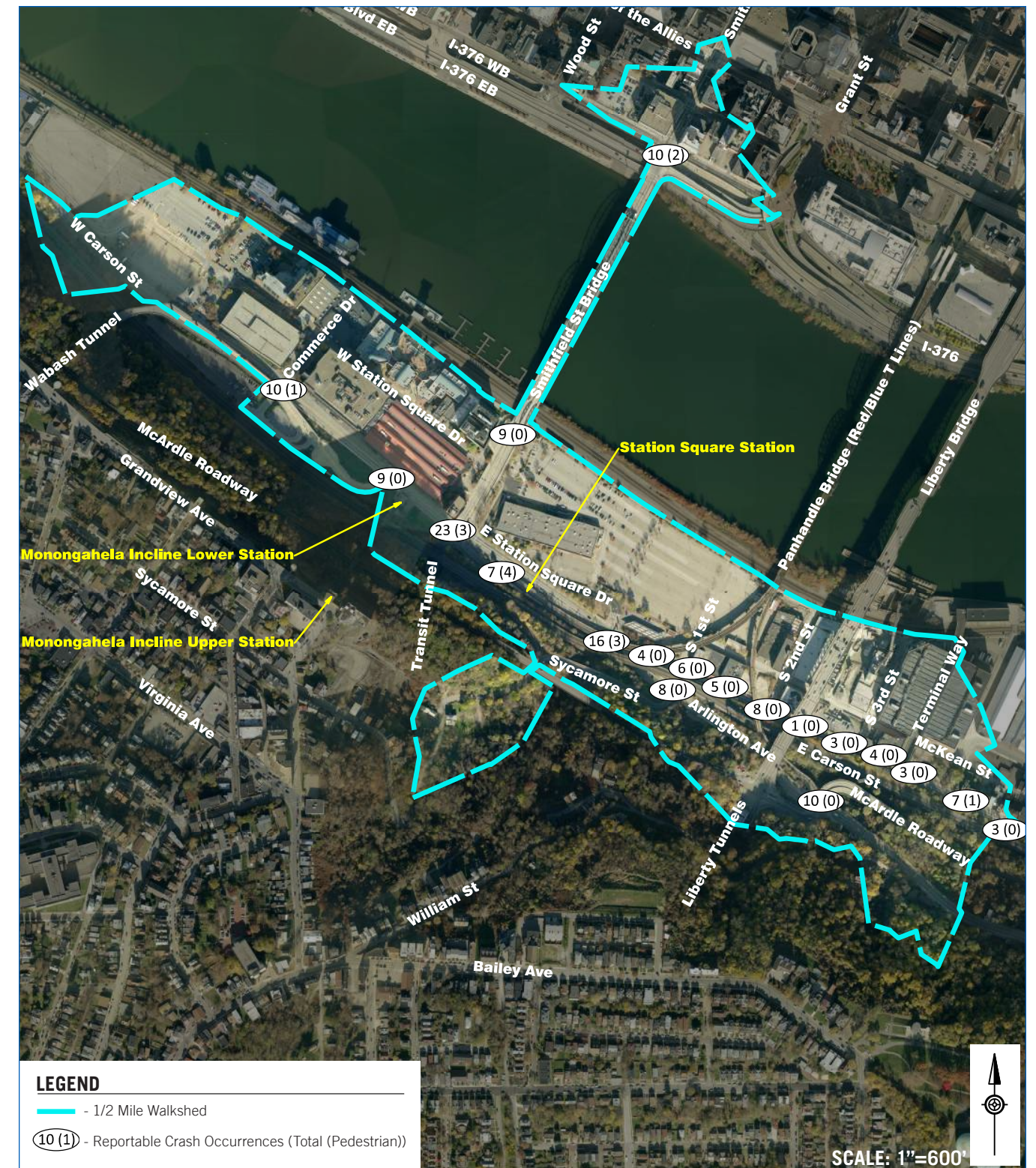

[Figure 1.2] Reportable Crashes from 2011 to 2015

TRANSPORTATION PLANNING

The Available Roadway Segment Crash Rate table shows that stretch of Arlington Avenue to Carson Street at Station Square Drive and then continuing along Carson Street through Smithfield Street to Commerce Drive has approximately double the crash rate of the other roadway segments. The Station Square station area is along these segments, and all pedestrians using transit must cross streets to reach the station. This shows the importance of safety improvements in this area.

Unlike computing vehicular crash rates per location, pedestrian crashes typically occur too infrequently to calculate statistically-significant rates; in the past five years, the variation between the highest and lowest intersection or roadway crash occurrences was four. Pedestrian crashes may also occur when pedestrians are third parties to vehicular crashes. Therefore, this assessment focuses recommending improvements to make intersections as safe as possible for all users to prevent situations that may lead to future crashes, regardless of past pedestrian crash occurrences. Vehicular safety improvements, especially ones that slow traffic volumes or reduce aggressive driving, will also help to lower pedestrian crash risks.

Since signalized intersections typically experience higher traffic volumes, they typically experience the greatest number of both pedestrian and vehicular crashes. Three ways of reducing aggressive driving at signalized intersections include installing exclusive turn lanes, adding advance exclusive turn arrows, and actuating the signals for vehicles. At uncontrolled locations, improving sight distance, signage, and crosswalk markings may reduce the risk of pedestrian crashes.

Considering crash rates and occurrences, crash data shows that the most critical area to improve is East Carson Street from Arlington Avenue to Smithfield Street.

This report provides recommendations for making improvements along these roadways to improve pedestrian safety within the Station Square Station's walkshed.

Intersection Observations

The GAI/CSG team performed field observations of all roadways in the highlighted pedestrian walkshed area to observe safety deficiencies. The field observations were conducted on March 21, 2017, prior to the PennDOT-planned safety improvement project scheduled for 2018-2019. The most significant issues observed were related to safe pedestrian access to the Station Square LRT Station and to the Monongahela Incline Lower Station, which included confusing signal phasing, frequent jaywalking, and narrow or discontinuous sidewalks that lacked buffers from travel lanes. Other common issues observed included missing and non-ADA compliant curb ramps, missing or faded crosswalk markings, misaligned crosswalks, missing stop signs, lack of bicycle connectivity, confusing lane arrangements, and a lack of ADA compliant pedestrian signals.

The following section describes general safety improvement recommendations along with specific examples of why such improvements are needed. These suggested safety improvements are summarized in **[Figure 1.5] Safety Assessment Observations**. The letters denoting each type of safety observation in the figure corresponds with the following report recommendations below. Since these are not formal audits they are not intended to be a complete and exhaustive list at all intersections. Many of these recommendations are also being proposed as part of the planned PennDOT safety project.

SAFETY ASSESSMENT OBSERVATIONS

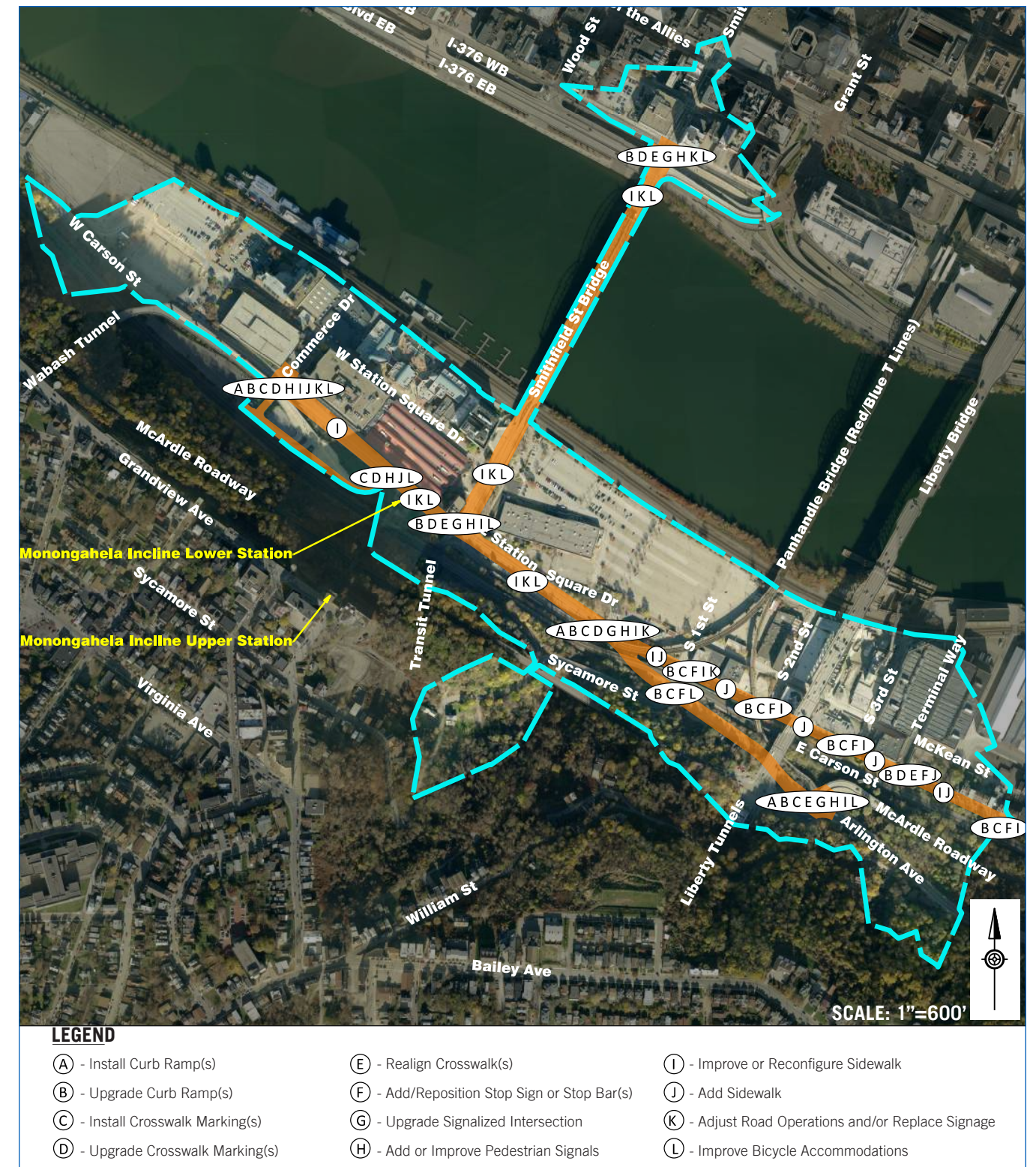

[Figure 1.5] Safety Assessment Observations

TRANSPORTATION PLANNING

RECOMMENDATION A - INSTALL CURB RAMP(S)

Intersection observations revealed missing curb ramps at some of the intersections, particularly the intersection of Arlington Avenue and McArdle Roadway and Carson Street and Arlington Avenue. Where sidewalks line up at signalized intersections, approaches should have straight, marked crosswalks with ADA-compliant curb ramps.



Guidance:

Add curb ramps at missing crosswalk locations.

Example:

Carson Street at Station Square Drive and Arlington Avenue



Guidance:

Add curb ramps at missing crosswalk locations.

Example:

Arlington Avenue at McArdle Roadway

RECOMMENDATION B – UPGRADE CURB RAMP(S)

Many of the curb ramps in the study area were installed prior to current ADA-standards, so they lack detectable warning surfaces and may have excessive slopes. Corners were observed to often have one shared ramp for two crossing directions, though the ramps may not be angled properly or the radius may not be large enough to permit on-street wheelchair

turning movements outside of vehicular wheel paths. Shared ramps should only be used for larger radii. The project team suggests upgrading all remaining curb ramps to be ADA-compliant.



Guidance:

Upgrade curb ramps to be ADA compliant and to point in the direction of pedestrian travel. Limit slopes to ADA maximums where possible.

Example:

East Carson Street and Arlington Avenue



Guidance:

Avoid the use of combined curb ramps when possible. If used, ensure pedestrians have adequate space for turning movements within crosswalks, per ADA standards.

Example:

Arlington Avenue and Sycamore Street



Guidance:

Some intersections have curb ramps that are too narrow and are more like sidewalk to pavement grade transitions. Use ADA-compliant ramps that meet width requirements.

Example:

Arlington Avenue and McArdle Roadway

TRANSPORTATION PLANNING

RECOMMENDATION B



Guidance:

Replace all deteriorated ramps.

Example:

Intersection of East Carson Street and South First Street

RECOMMENDATION C – INSTALL CROSSWALK MARKING(S)

Smaller intersections were observed to lack crosswalk markings. While crosswalk markings are not required at all intersections, especially for low volume roads, they should be painted for all crossings that might be confusing to either drivers or pedestrians, such as at intersections with angled approaches or crossing T-tracks. Any location in which drivers may not expect pedestrians should have marked crosswalks with a corresponding stop bar.

At signalized intersections, where feasible, crosswalks should be located for each crossing movement. Missing crosswalks include across Carson Street at the west side of the Arlington Avenue intersection, at the east side of the Wabash Tunnel intersection, and at the east side of the Commerce Drive intersection. Appropriate curb ramps and sidewalk connections must be made to connect new crosswalks. The intersection of Commerce Drive has a west-side crosswalk to nowhere and is missing an east side crosswalk that is used by pedestrians heading to and from Station Square.

Discretion should be used when marking crosswalks at uncontrolled locations, since marked crosswalks have been shown to give pedestrians a false sense of security. Marked midblock crosswalks were observed across East Carson Street at Terminal Way and formerly across Arlington Avenue at Sycamore Street (the markings were worn). When uncontrolled crossings are used at these locations, intersections, they should line up with the most convenient pedestrian path and have painted crosswalks across both sides of the uncontrolled roadway with as corresponding stop bars (or yield triangles) and advance warning signage. New markings at midblock and uncontrolled crosswalks should not be installed unless recommended by a specific safety study.

While standard parallel-style markings are acceptable for lower volume crosswalks, crosswalks at midblock or high traffic locations (most locations within the station's walkshed) should have high visibility piano key-style markings.

RECOMMENDATION C



Guidance:

Install crosswalk markings across all signalized intersection approaches where feasible, especially where they line up with sidewalks.

Example:

West Carson Street and Commerce Drive

RECOMMENDATION C



Guidance:

Install crosswalks at stop-controlled locations that have sidewalks to discourage vehicles from stopping in pedestrian paths without watching for pedestrians first.

Example:

East Carson Street and South Third Street

RECOMMENDATION C



Guidance:

At existing uncontrolled locations, upgrade crosswalk markings with high-visibility piano key markings. At uncontrolled intersections, mark crosswalks across all approaches and add stop bars or yield triangles to supplement the advance signage. Install crosswalk to align with pedestrian path, such as the bus stop at Terminal Way.

Example:

East Carson Street and Terminal Way

RECOMMENDATION C



Guidance:

Mark crosswalks along higher volume streets, especially where drivers may not look for pedestrians.

Example:

Arlington Avenue and McArdle Roadway

TRANSPORTATION PLANNING

RECOMMENDATION D – UPGRADE CROSSWALK MARKING(S)

Signalized intersections were generally observed to all have parallel-style crosswalk markings (when used), and smaller intersections and curb cuts with larger driveways often had no markings. Many of the crosswalk markings were observed to be faded. The project team suggests regular inspection intervals for crosswalk markings. Piano key-style crosswalk markings have been shown to be more visible and require less maintenance. The project team recommends upgrading parallel markings to piano key-style markings, especially at high-volume and midblock locations, such as along Carson Street and Smithfield Street.

RECOMMENDATION D



Guidance:
Upgrade parallel-style markings to piano-key style markings at high-volume intersections.

Example:
Intersection of Smithfield Street and Carson Street

RECOMMENDATION D



Guidance:
Maintain and repaint faded crosswalk markings.

Example:
Intersection of Carson Street and the Wabash Tunnel Ramp

RECOMMENDATION E – REALIGN CROSSWALK(S)

Crosswalks and curb ramps at various intersections were observed to be misaligned. While this is typically due to utility conflicts and roadway obstructions, misaligned crosswalks increase pedestrian walking time and exposure to vehicles within the intersection. They also lead to pedestrian non-compliance and low driver visibility. However, crosswalks should also be placed at feasible locations for ADA-compliant curb ramps. For busy sidewalks, such as along Smithfield Street and along Carson Street between the LRT and incline stations, crosswalks and curb ramps should be positioned so pedestrians

waiting to cross the street do not block pedestrians walking past the crossing.

At the intersection of Arlington Avenue and McArdle Roadway, the LRT tracks do not experience regular service, and the LRT has its own signal phase. Realigning the inbound crosswalk to be parallel to Arlington Avenue may improve pedestrian safety and convenience and should be studied further. At intersections like Smithfield Street and Fort Pitt Boulevard, crosswalks are located back from curb radii, behind obstructive street furniture such as a traffic signal cabinet and a pedestrian map.

RECOMMENDATION E



Guidance:
Realign crosswalks to shorten pedestrian paths.

Example:
Intersection of Carson Street and Smithfield Street

RECOMMENDATION E



Guidance:
Provide straight crossing paths in visible locations optimized for pedestrian use.

Example:
Intersection of Arlington Avenue and McArdle Roadway

RECOMMENDATION E



Guidance:
Place crosswalks in visible locations close to intersection corners.

Example:
Intersection of Smithfield Street and Fort Pitt Boulevard

TRANSPORTATION PLANNING

RECOMMENDATION F – ADD OR REPOSITION STOP SIGN OR STOP BAR(S)

Place stop signs at all applicable locations in which traffic should stop, such as South First Street, South Second Street and Terminal Way approaching East Carson Street. Where stopping traffic crosses a pedestrian marked or unmarked crosswalk, paint a stop bar a minimum of four feet in advance of the crosswalk, aligned with a stop sign.



Guidance:
Mount stop signs at all intersection approaches where traffic must stop.

Example:
Intersection of East Carson Street and South First Street



Guidance:
Stripe stop bar a minimum of four feet in front of all marked and unmarked pedestrian crosswalks.

Example:
Intersection of East Carson Street and South Second Street

RECOMMENDATION G – UPGRADE SIGNALIZED INTERSECTIONS

Some of the traffic signals run in a pre-timed pattern and do not use the latest technology. Actuated signals are programmed to reduce the chance of changing in the “dilemma zone” (when the driver experiences the dilemma of either going through the yellow indication or stopping quickly). Pre-timed signals only change based on specific timing patterns, pre-programmed for traffic flows.

Some of the signalized intersections in the study area have protected-permissive phasing in which a phase starts with a green arrow and a green ball and then the green arrow goes dark when the opposing movement gets a green ball indication. Without an exclusive turning lane, such as along Carson Street, turning traffic blocks through movements. Reallocating lane configurations to give all left turns their own lane could improve safety and reduce congestion. Eastbound Carson Street could have an exclusive left turn lane and a through lane at Smithfield Street and a short exclusive left turn lane, through lane, and right turn lane at the Station Square Drive and Arlington Avenue intersection. This configuration would require the northbound Arlington Avenue approach to be reconfigured to an exclusive left lane (to westbound Carson Street) and a right lane (to Station Square Drive and eastbound Carson Street). As part of the project, the team performed an informal evaluation that concluded these traffic patterns could operate at similar levels of service, though a formal traffic study is needed for more conclusive results. The current entrance to the Wabash Tunnel lacks a turn lane, though there is a left turn lane at Commerce Drive which also provides Wabash Tunnel access.

For movements that retain protected-permissive operations, a flashing yellow arrow may be a safer and more flexible

indication, since it can be safely used for both leading and lagging turn phases.

When the current signals were installed, signal phasing only gave the option of pedestrians walking concurrently with traffic flows or separately in their own exclusive phase. While an exclusive pedestrian phase theoretically should prevent pedestrian crashes, it extends the cycle length so pedestrians may be less likely to wait for a walk signal. Pedestrians are accustomed to cross during green indications, so they may think they do not need to wait for the walk indication when it is separate. Meanwhile, the intersection of Smithfield Street and Carson Street runs inefficiently in which pedestrians on the west side cross concurrently with turning traffic (resulting in traffic congestion during the afternoon peak period) and pedestrians on the east side essentially have an exclusive movement, since their push button-actuated phase lines up with the Transit Tunnel exit, a phase no longer called by vehicles. Therefore, Smithfield Street pedestrians cross Carson Street at different times in the cycle, resulting in confusion and a long cycle length.

Many signals both locally and nationally are now being programmed with leading pedestrian intervals (LPIs) that give pedestrians a head start of three to five sections of exclusive crossing time prior to concurrent vehicular green indications with lagging turn arrows. The project team suggests studying using LPIs at high-pedestrian crossing intersections such as along Smithfield Street both at Carson Street and at Fort Pitt Blvd.



Guidance:
Consider installing LPIs at signalized intersections with high pedestrian volumes.

Example:
Intersection of Carson Street and Smithfield Street

TRANSPORTATION PLANNING

RECOMMENDATION G



Guidance:
Review lane allocation to determine if left turn lanes can be provided.

Example:
Intersection of East Carson Street, Arlington Avenue, and Station Square Drive

RECOMMENDATION G



Guidance:
Install actuation to improve pre-timed signals.

Example:
Intersection of Smithfield Street and Fort Pitt Boulevard

RECOMMENDATION H – ADD OR IMPROVE PEDESTRIAN SIGNALS

Many of the signalized intersections lack modern or accessible pedestrian signal heads and push buttons. Reconfigure all deficient intersections to have ADA-compliant pedestrian signals (such as pushbuttons with vibrotactile arrows, audible pedestrian indications, etc.) and countdown timers. Some have faded or obstructed signs.

The signalized intersection of Arlington Avenue and McArdle Roadway lacks pedestrian signal heads. Due to the at-grade LRT crossing, the intersection has louvered signals, optimized for drivers, but potentially obstructed for pedestrians. McArdle Roadway curves into and out of the intersection, so pedestrians and vehicles may not be able to see each other. Add fully ADA-compliant pedestrian signals to the intersection. Additionally, current “Push Button for Green Light” signage is not at accessible locations.

RECOMMENDATION H



Guidance:
Add ADA-compliant pedestrian signals with countdown timers.

Example:
Intersection of Smithfield Street and Fort Pitt Boulevard

RECOMMENDATION H



Guidance:
Place all pedestrian push buttons at accessible locations.

Example:
Intersection of Arlington Avenue and McArdle Roadway

RECOMMENDATION H



Guidance:
Replace faded or obstructed pedestrian signs.

Example:
Intersection of Carson Street and Smithfield Street

RECOMMENDATION H



Guidance:
Ensure pedestrians can see vehicular traffic signals, especially in locations without pedestrian signals.

Example:
Intersection of Arlington Avenue and McArdle Roadway

TRANSPORTATION PLANNING

RECOMMENDATION I – IMPROVE OR RECONFIGURE SIDEWALK

Deterioration and improper sidewalk maintenance results in tripping and drop-off hazards. Sidewalks along Carson Street has several observed hazards, including deteriorated slabs and missing railings to adequately protect pedestrians along hillsides. Landscaping alongside sidewalks was observed to slide into the sidewalk creating tripping hazards. Expansion joint covers on the Smithfield Street Bridge were observed to create tripping hazards.

Sidewalks without street buffers do not adequately protect against pedestrian and vehicle interactions. Along Carson Street between Arlington Avenue and Smithfield Street, pedestrians are observed to cross midblock. There was a fatality reported in this area due to a vehicle whose driver had a medical emergency and encroached onto the sidewalk.

Pedestrian fences are effective, but they do not create a welcoming environment. They create barriers to effective transit stops, since the spot buses pickup and discharge passengers may vary due to conditions caused by traffic and other buses. Gates at driveway locations, such as adjacent to the Monongahela Incline, may block sidewalk use. Avoid obstructions that can block sidewalks.

At intersections with sight distance obstructions from pedestrians or parked cars, drivers were observed to encroach into areas where pedestrians may be crossing. Installing curb extensions (bump-outs) can shift pedestrian crossings away from sight distance conflicts from side streets, thus improving pedestrian visibility. They can also prevent parked cars from obstructing sight distance. Relocate street furniture and pedestrian amenities if they are placed along sidewalks in front of curb ramps, since they can block sight distances. This was observed from the Smithfield Street Pedestrian Map at Fort Pitt Boulevard.

Some sidewalks were observed to be too narrow for pedestrians. The sidewalk was measured to be less than four feet wide along Arlington Avenue, which is less than permitted by ADA standards, though there are geometric challenges in this area. The sidewalk in front of the Monongahela Incline was observed narrow and crowded when the incline's queue spills outside of the station. The only sidewalk from Smithfield Street and the Monongahela Incline to the Station Square LRT Station was measured to be four feet wide. While ADA-compliant, pedestrians were observed to walk into Carson Street to avoid overcrowding. Update sidewalks were possible to ensure ADA-complaint widths in all places. Provide wider sidewalks that experience high pedestrian flows, especially at primary access routes to transit stations.

Guidance:
Properly maintain sidewalks and landscaping to avoid tripping hazards.

Example:
West Carson Street at Commerce Drive

Guidance:
Install protective fencing at drop-off locations.

Example:
East Carson Street at the 4th Street Stairs

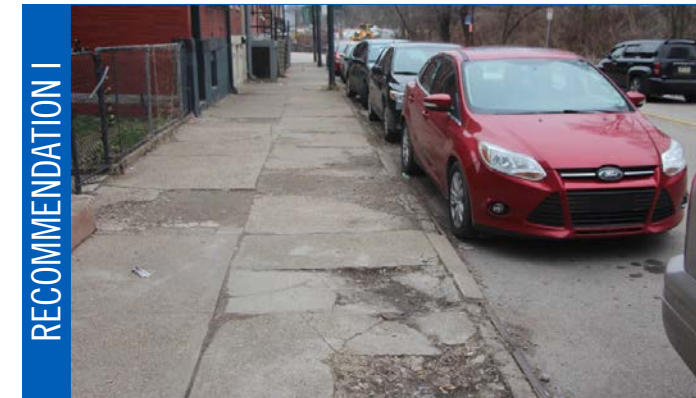

Guidance:
Replace damaged sidewalks to eliminate tripping hazards.

Example:
East Carson Street by South Fifth Street

Guidance:
Add sidewalk buffer to protect pedestrians from travel lanes where possible.

Example:
East Carson Street by Station Square LRT Station

Guidance:
Add sidewalk buffer to reduce jaywalking.

Example:
East Carson Street by Station Square LRT Station

Guidance:
Remove obstructive pedestrian fences and gates.

Example:
West Carson Street by Monongahela Incline

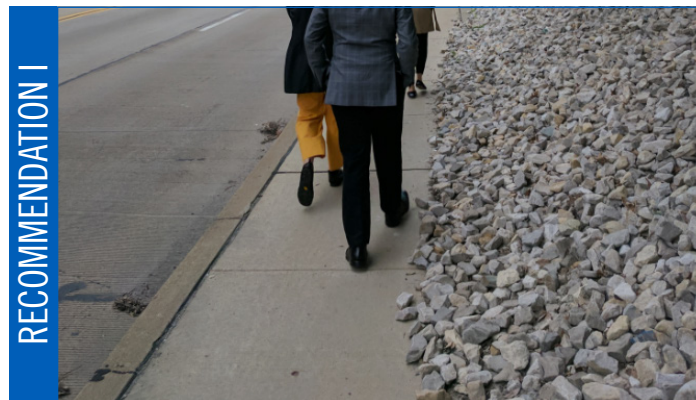

TRANSPORTATION PLANNING

RECOMMENDATION I



Guidance:
Install bump-outs at intersections with limited sight distance

Example:
East Carson Street at South 3rd Street

RECOMMENDATION I



Guidance:
Provide ADA compliant width. If width cannot be achieved due to obstruction, provide adequate width on the opposite side of the street.

Example:
Sidewalk to Station Square LRT Station

RECOMMENDATION I



Guidance:
Widen sidewalks in areas with high pedestrian flows, especially at primary routes to transit stations.

Example:
Intersection of Carson Street and Smithfield Street

RECOMMENDATION I



Guidance:
Remove sidewalk obstructions that are placed between curbs and crosswalks.

Example:
Smithfield Street and Fort Pitt Boulevard

RECOMMENDATION J – ADD SIDEWALK

The project team noted several gaps in sidewalk connectivity in the area around the Station Square Station, and some routes used by pedestrians had “No Pedestrians” signs. Despite the South Side being a densely-developed neighborhood with a parking shortage, there is only a sidewalk connection to the Station Square Station and Incline on Carson Street’s north side. Therefore, pedestrians may have to cross Carson Street twice to reach the transit stations. Within the stretch without a sidewalk, there is an unprotected bus stop at Terminal Way in which pedestrians must stand on the roadway shoulder. Since there is an unused paved shoulder between the existing bicycle

lane and the ashlar wall, install the missing sidewalk. Sidewalk infrastructure along Carson Street behind the Station Square development has several gaps. There is a missing sidewalk across Carson Street from the Monongahela Incline. Despite the “No Pedestrian” signs, pedestrians were observed to disregard the sign. There are no sidewalks at the Commerce Drive entrance to Station Square (“No Pedestrian” signs are posted), yet Commerce Drive is the main pedestrian route from the Wabash parking lot to Station Square.

RECOMMENDATION J



Guidance:
Add sidewalks at locations used by pedestrians.

Example:
West Carson Street west of Smithfield Street

RECOMMENDATION J



Guidance:
Connect gaps in sidewalk infrastructure.

Example:
Commerce Drive entering Station Square

RECOMMENDATION J



Guidance:
Add sidewalks at transit stops.

Example:
Intersection of East Carson Street and Terminal Way

TRANSPORTATION PLANNING

RECOMMENDATION K –ADJUST ROAD OPERATIONS AND/OR REPLACE SIGNAGE

Safe roadway design and operations benefits both drivers and pedestrians. Ideally, complete streets surrounding transit stations should have wide sidewalks, buffers from travel lanes, slow vehicular speed limits, tight radii to slow turning vehicles, turning lanes for vehicles to safely queue, and more. In a congested urban environment, such as the area surrounding the Station Square and Monongahela Incline stations, there is insufficient room for all of these operations. However, only certain vehicular movements experience congestion, so there may be unneeded capacity that could be reallocated for improved safety for all users.

Due to the narrowness of the sidewalk and location of the Monongahela Incline Lower Station, roadway reconfiguration to reallocate space from the eastbound curb lane to increase the sidewalk area in front of the incline station could help station operations and improve safety and accessibility. Potential ways to mitigate vehicular delay could include closing the eastern entrance to the Wabash Tunnel, requiring drivers to turn at Commerce Drive where there is an existing left turn lane.

Due to the limited width of the south side Carson Street sidewalk between Smithfield Street and the Station Square LRT Station, as well as the frequent bus stops in front of the LRT station, study single-lane eastbound Carson Street operations that would allow for a wider sidewalk and a safe place for buses to stop without blocking through traffic.

Large turning radii increases turning vehicle speeds that conflict with concurrent pedestrian crossings. The radius at the westbound right turn from Carson Street to the inbound Smithfield Street Bridge has an atypically wide radius from the streetcar era, resulting in high vehicular turning speeds, long pedestrian crossing distances, and a bus stop away from the corner. Improve the radii to allow safer operations at the intersection.

The Smithfield Street southbound approach to Carson Street is flared and has concrete median curbs, resulting in a 90 foot crossing distance for a four-lane approach. Consider removing the concrete curbs and using 11-foot lanes to minimize pedestrian crossing distances.

Vehicles travel along Carson Street at a high rate of speed, being one of only a few roads in the City of Pittsburgh posted at 35 mph (west of the Station Square LRT Station). Consider reducing speed limits on roads with high pedestrian use to 25 mph.

Carson Street experiences typical westbound queuing approaching Arlington Avenue, so vehicles making a left turn onto roads such as first street block through traffic. Either provide turning lanes or prohibit problematic left turns.

Guidance:
Narrow curb radii to slow vehicular speeds for right turning vehicles.

Example:
Intersection of Smithfield Street and Carson Street



Guidance:
Study adjusting roadway operations to install turn lanes, bus pull-offs, and wider sidewalks in roadway lanes with excess capacity.

Example:
Eastbound Carson Street from the Monongahela Incline to the Station Square LRT Station



Guidance:
Post speed limits of 25 mph along roadways with a lot of pedestrian activity, such as Carson Street between the Wabash Tunnel and Arlington Avenue.

Example:
Carson Street



Guidance:
Prohibit left turns in areas where high conflicting volumes and lack of available space for turn lanes could create congestion and angle or rear-end collision issues, especially immediately downstream of signalized intersections.

Example:
Carson Street and 1st Street

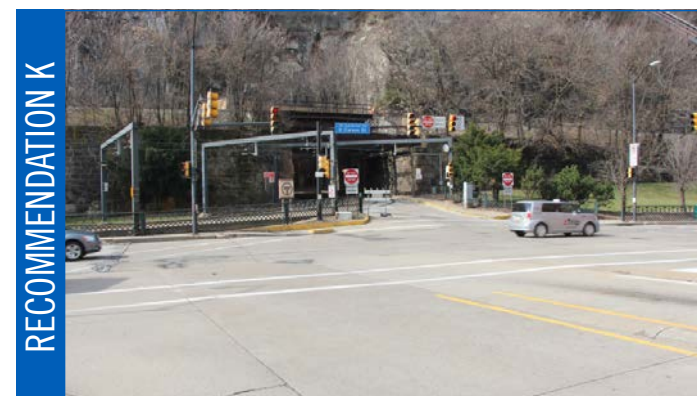

Guidance:
Narrow intersection approaches that have excess width to reduce pedestrian crossing distances.

Example:
Smithfield Street southbound approach to Carson Street

TRANSPORTATION PLANNING

RECOMMENDATION L – IMPROVE BICYCLE ACCOMMODATIONS

The area around the Station Square LRT Station and the Monongahela Incline Lower Station has a lot of bicycle activity, especially since there are riverfront trails on both sides of the Monongahela River and bike trail ramps being added to the Smithfield Street Bridge in 2017-2018. Smithfield Street is emerging as an important bicycle connection between the Station Square Station, Carson Street, bike trails, and downtown. There is a bicycle lane along Carson Street eastbound from Arlington Avenue into the South Side and the bridge's eastern sidewalk is designated a bicycle and pedestrian shared sidewalk. Therefore, the largest gap in the bicycle network is in the Carson and Smithfield Street area immediately

surrounding the stations. Examine areas to improve bicycle connectivity, such as additional bicycle lanes or shared lane markings. Infrastructure such as the Wabash Tunnel and inbound Smithfield Street Bridge may have unused roadway width that could accommodate bicycle lanes.

The project team suggests replacing all inlets with bicycle-safe grates. The team also suggests installing bike racks (or working with private property owners to install bike racks) at locations with bicycle use, such as businesses and apartment buildings. Additional bicycle infrastructure is recommended at the Station Square Station as part of the station design process.



RECOMMENDATION L

Guidance:
Use bicycle safe grate designs.

Example:
Intersection of Carson Street and Smithfield Street

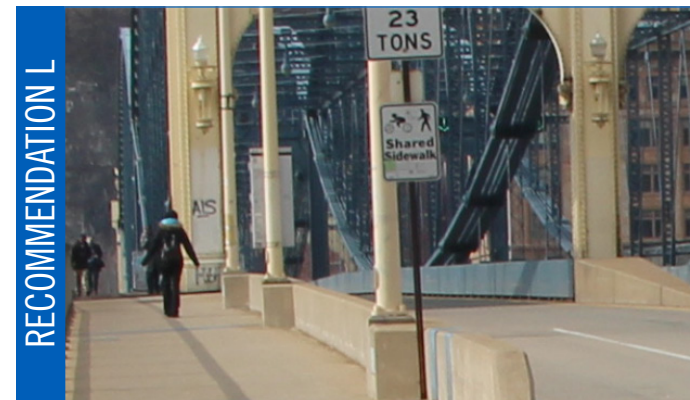

RECOMMENDATION L

Guidance:
Study whether or not unused paved areas can accommodate bicycle lanes.

Example:
Smithfield Street Bridge



RECOMMENDATION L

Guidance:
Examine gaps in the bicycle network and study how links can be appropriately improved

Example:
Smithfield Street

TRANSPORTATION PLANNING

INTERSECTION OBSERVATIONS SUMMARY

Refer to **[Figure 1.5] Safety Assessment Observations** figure for the locations of the safety improvement recommendations. A summary is as follows:

East Carson Street from South Fifth Street to Arlington Avenue

Upgrade most of the intersections along this stretch with curb extensions to improve sight distance concerns. Add ADA-compliant curb ramps. Add stop signs to the side streets where they are missing, paint corresponding stop bars, and mark crosswalks using high visibility markings. Add a sidewalk along Carson Street's eastbound side between the bicycle lane and the retaining wall to connect the Station Square LRT Station and South Side neighborhood and to give pedestrians at the bus stops along this stretch a safe place to stand. Use high-visibility crosswalk markings with corresponding pedestrian fluorescent warning signs and stop bars (or yield triangles) for convenient midblock crossings to bus stops. Repair deteriorated portions of existing sidewalks and add protective fencing where needed, such as near the South Fourth Street stairs where there is a drop-off from the back of the sidewalk. Provide better connectivity to the existing bicycle infrastructure and repair drainage structures to be safe for bicycles and pedestrians. Install no left turn signage for corners that may have sight distance problems or queuing issues.

Intersection of East Carson Street and Arlington Avenue

Add the missing crosswalk on the intersection's west side and upgrade crosswalk markings with high-visibility, perpendicular "piano key" style markings. Use ADA-compliant curb ramps for all crossings. Study upgrading intersection phasing and lane assignments to provide left turn lanes for all approaches. Use flashing yellow arrows for permitted left arrows. Upgrade pedestrian signals and use LPIs. Improve deteriorated sidewalks and improve their lighting and attractiveness beneath the LRT and railroad structure.

East Carson Street from Arlington Avenue to Smithfield Street

Replace deteriorated sidewalks. Widen the narrow four-foot strip of sidewalk connecting to the LRT station since pedestrians were observed to walk into Carson Street due its narrow width. Consider moving the inbound bus stop closer to the corner of Smithfield Street and adding planted buffers where applicable to encourage pedestrians to cross at the signalized intersection of Smithfield Street. Upgrade bicycle infrastructure to add connectivity to the station and the eastbound Carson Street bicycle lane beyond Arlington Avenue. Optimize roadway configuration to include a dedicated area for buses to stop and study exclusive left and right turn lanes at adjacent intersections.

Intersection of East and West Carson Street and Smithfield Street

Upgrade the intersection to focus on pedestrian safety, since it is the critical link to the Port Authority's bus, light rail, and transit facilities. Add accessible pedestrian curb ramps and signals, and use high-visibility crosswalk markings. Shorten pedestrian crossing distances as much as possible and reduce the maximum cycle length to reduce wait times. Since pedestrians crossing Carson Street conflict with turning vehicles from the Smithfield Street Bridge, use appropriately-timed LPIs and lagging left turns to minimize conflicts. Convert the eastbound shared left and through lane to be an exclusive left turn lane to the Smithfield Street Bridge to simplify operations. However, this should be balanced by widening the sidewalk on the intersection's east side to provide a buffer between increased right lane through traffic and the station. Use bicycle-safe grates and consider ways to better connect bicycle use from the Smithfield Street Bridge to the station area.

West Carson Street from Smithfield Street through Commerce Drive

Improve the pedestrian connection to the Monongahela Incline by widening the sidewalk and adding a sidewalk buffer from the travel lanes. Improve pedestrian connectivity between Station Square and the Monongahela Incline by adding a sidewalk and missing crosswalks from Smithfield Street to Wabash Street on the north side of Carson Street and along Commerce Drive crossing the east side of Carson Street to Station Square's Freight House Shops entrance. Upgrade crosswalk markings and pedestrian signals, and keep the sidewalk free from tripping hazards, especially from landscaping beneath the Wabash Tunnel's ramp. Connect the isolated curb ramp at the Commerce Drive intersection. Add LPIs to signals and adjust roadway operations to reduce or eliminate turns without exclusive left turn lanes. Install bicycle-safe grates.

Smithfield Street from Carson Street though Fort Pitt Boulevard

Upgrade curb ramps and traffic signals to be ADA-compliant and use high-visibility crosswalk markings. Improve bicycle infrastructure and connections. Remove sidewalk obstructions and locate crosswalks close to curb radii to improve visibility for pedestrians from turning vehicles. Use actuation to reduce pedestrian wait times and LPIs to allow for safer pedestrian crossings.

Arlington Avenue from East Carson Street to McArdle Roadway

Improve sidewalk connectivity and widen sidewalks at pinch points to maintain minimum four-foot wide sidewalks. Since marked uncontrolled midblock crosswalks can be unsafe and should be avoided if possible, improve sidewalk conditions along Arlington Avenue and maintain the Arlington Avenue crossing at sycamore Street as unmarked. Install ADA-compliant curb ramps and use high-visibility piano-key crosswalk markings. Place stop signs four feet back from crosswalks and paint stop bars.

Intersection of Arlington Avenue and McArdle Roadway

Install missing curb ramps and upgrade all of the curb ramps so they are ADA-complaint. Place push buttons in accessible locations and install pedestrian signals. Realign crosswalks to provide straight crossing paths, or provide pedestrian refuge islands if crosswalks cannot be made straight. Use push-button actuated LPIs, which are especially important due to sight distance limitations at the intersection. Use bicycle-safe grates.

TRANSPORTATION PLANNING

STATION SQUARE STATION SURVEY ANALYSIS

In the fall of 2016, the Port Authority conducted a user survey at Station Square LRT and bus station. Riders had the opportunity to describe what they would like to see to make the station better as well as to specify their barriers and obstacles to using the station. Responding to what they would like to see to make the Station Square station better, 18 percent responded safety and 11 percent responded pathways. Both of these responses are related; to reach the station pedestrians must cross busy Carson Street and walk along the narrow sidewalk pathway to reach the station.

Responding to the question about barriers and obstacles to station use, 17 percent felt unsafe from traffic, 7 percent reported sidewalks, and 2 percent reported crosswalks. User comments indicated concerns with the length of the traffic signal cycle crossing Carson Street, the high traffic volumes along Carson Street, the perceived unsafe crosswalks across Carson Street, and the difficulty of crossing Carson Street midblock from the bus stop to the LRT station (jaywalking). Comments included, "The crosswalks surrounding [the station] are unsafe and do not prioritize pedestrian traffic," and "Add a bike rack and a slightly wider sidewalk when heading to the Smithfield Street Bridge."

Therefore, about a third of station users feel that the Station Square station area needs to be improved to promote pedestrian safety and accessibility.

SAFETY EVALUATION SUMMARY

The safety evaluation analyzed high-crash locations, field viewed the station's walkshed, and reviewed station user safety results. The results of these analyses will serve to improve the safety and security of Station Square station area users, as well as the traveling public in general. While most of these improvements are outside of the Port Authority's control, they can be applicable to future City/State, utility, and private development projects near the station, examples of which are

all underway. The most critical area to improve is along Carson Street from Arlington Avenue to the Monongahela Incline Lower Station.

OPERATIONS ANALYSIS

Appropriate station redesign should analyze how a station is currently being used in order to maximize its utility for future use. This study incorporated pedestrian and vehicular data collection observations to create recommendations for station redesign.

SUMMARY OF DATA COLLECTION IN THE STATION SQUARE STATION AREA

The project team performed data collection capturing pedestrian, bicycle, and vehicular movements in and around the Station Square station area. The project team contracted with Miovision Traffic Data Online to perform video counts on Thursday, March 23rd from 7:00 AM to 9:00 AM and from 4:00 PM to 6:00 PM at the following intersections along Carson Street:

- Commerce Drive
- Wabash Tunnel
- Smithfield Street
- Arlington Avenue and Station Square Drive

During those hours, the morning peak hour capturing the highest vehicular volume was from 7:30 AM to 8:30 AM and the afternoon peak hour was from 5:00 PM to 6:00 PM. Refer to the [Figure 1.6] Carson Street Peak Hour Volumes for a summary of morning and afternoon peak hour vehicular volumes. Pedestrian counts are provided in the [Figure 1.7] Carson Street Peak Hour Pedestrian Volumes and bicycle counts are provided in [Figure 1.8] Carson Street Peak Hour Bicycle Volumes.

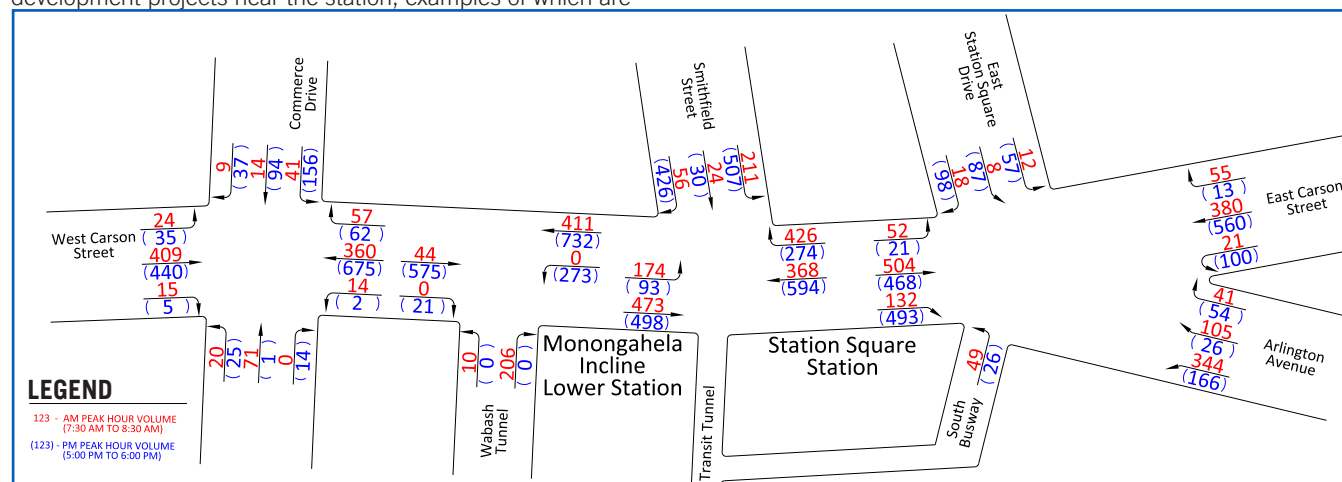

[Figure 1.6] Peak Hour Vehicular Volumes

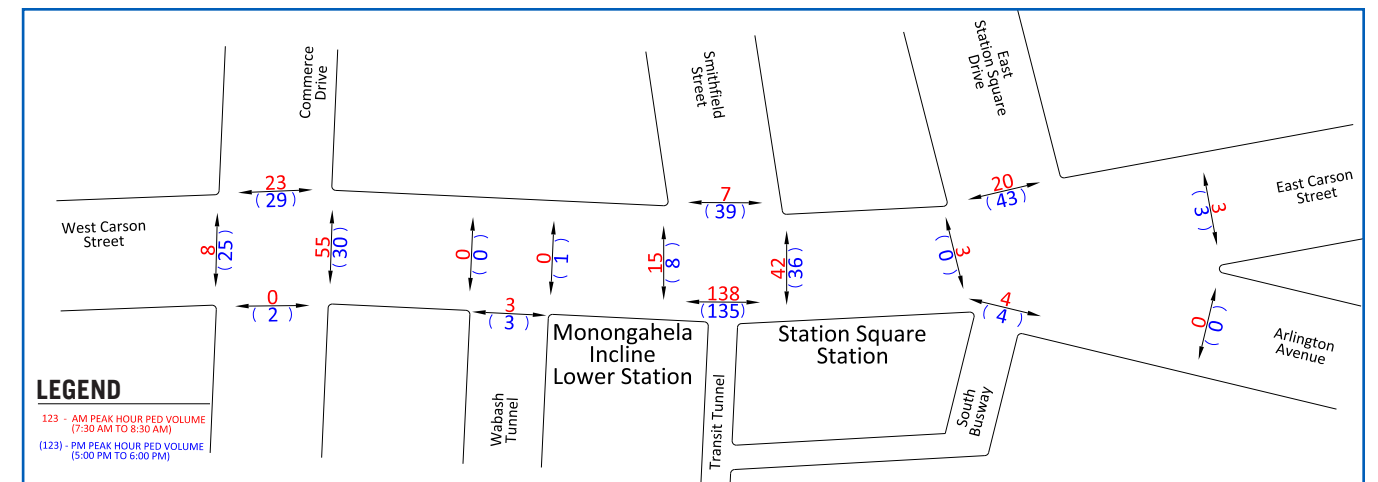

[Figure 1.7] Peak Hour Pedestrian Volumes

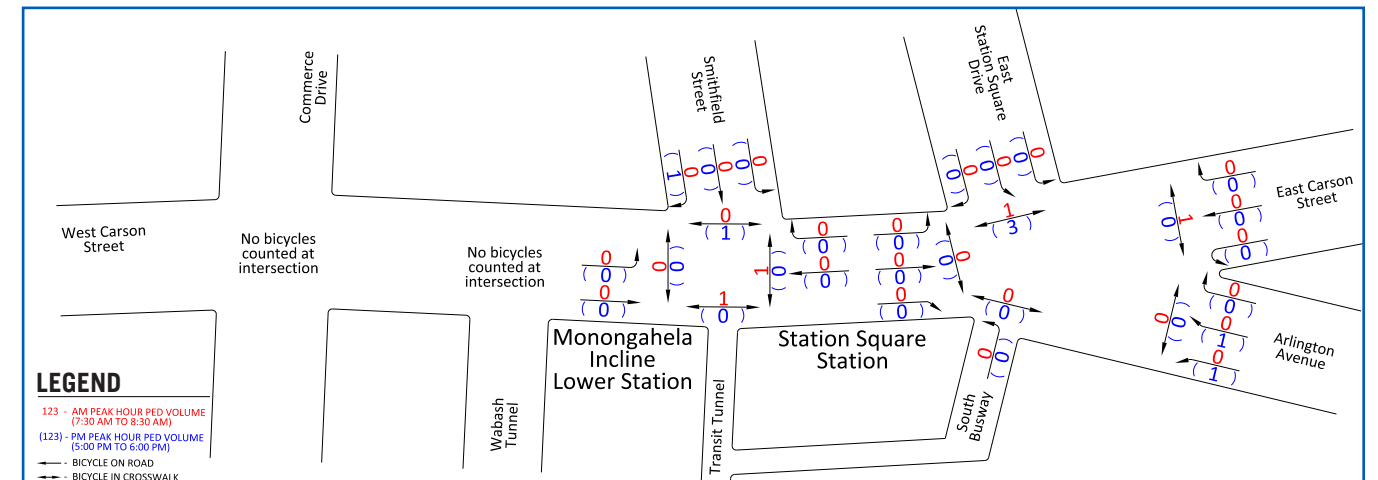

[Figure 1.8] Carson Street Peak Hour Bicycle Volumes

Vehicular data collection summary shows that the heaviest movements are along Carson Street westbound (outbound) and the Smithfield Street Bridge southbound (outbound) during the afternoon peak hour. The maximum number of vehicles observed in a single-lane movement was between 500 and 600 vehicles per hour, suggesting the upper limit of capacity of a single lane at an intersection, dependent on signal timing and phasing. Data collection did not assess the impact unmet demand, where volume is greater than capacity. Data collection revealed relatively few left turns from eastbound Carson Street to the Smithfield Street Bridge, with an average demand of fewer than 3 vehicles per minute. This shows the impact of the Fort Pitt Bridge ramps from Carson Street to the west.

Pedestrian data shows the highest pedestrian volumes were near transit stations along Smithfield Street and Carson Street. The intersection of Smithfield Street and Carson Street experienced between 200 and 220 pedestrian crossings (across all intersection approaches) in the peak hours. More pedestrians walk along the south side of Carson Street (crossing the Transit Tunnel approach) than were counted to cross Carson

Street, which suggests a lot of incline to bus or LRT transfers or a lot of jaywalking. Nearly 140 pedestrians crossed the Transit Tunnel approach to Carson Street during both peak hours, yet only 60 pedestrians in the morning and 45 pedestrians in the evening crossed Carson Street in the same area. Therefore, this operational analysis recommends a wider pedestrian sidewalk with a buffer to prevent jaywalking along Carson Street's south side.

At the intersection of Smithfield Street and Carson Street, between 75 percent and 85 percent of pedestrians crossed Carson Street on the intersection's east side. The Smithfield Street Bridge's west sidewalk is known to be busier. While the east crosswalk may be more convenient for bus to LRT transit connections, the east crosswalk's walk indication is tied to the Transit Tunnel phase, a prohibited vehicular movement with no vehicle calls. Therefore, these pedestrians can cross Carson Street in an exclusive movement, while pedestrians crossing on the intersection's west side do so concurrently with turning traffic. The pedestrian volume shows that pedestrians prefer to cross separate from turning traffic.

TRANSPORTATION PLANNING

Pedestrian counts revealed that pedestrians are crossing illegally where no pedestrian signs are posted. At the northeast corner of the Commerce Drive intersection, “No Pedestrian” signs are mounted facing both crossings. During the morning peak hour, 55 pedestrians crossed Carson Street and 23 pedestrians crossed Commerce Drive to reach this corner. During the afternoon peak hour, 30 pedestrians crossed Carson Street and 29 pedestrians crossed Commerce Drive. This crossing is the link between the Port Authority’s lot beneath the Wabash Tunnel and Station Square. These counts demonstrate the need for marked crosswalks at this location. Additionally one pedestrian was counted crossing Carson Street at the east side of the Wabash Tunnel approach and three pedestrians on the west side of the Arlington Avenue approach. Pedestrians will take the most convenient path when possible, regardless of signage or signal operations.

Bicycle data collection analysis reviewed very few bicycles within the station area, suggesting limited bicycle throughput. No bicycles were observed along West Carson Street at the Wabash Tunnel and Commerce Drive intersection. Despite Smithfield Street being an important bicycle link and having a shared sidewalk and East Carson Street having a bicycle lane

eastbound beyond Arlington Avenue, data collection may suggest that bicycles are using Station Square internal roadways for connectivity and are not using transit. Therefore, no further operation recommendations are offered for improving bicycle operations along Carson Street. It is important to note that data collection was performed in March; bicycle usage may be higher in other months.

EXISTING ROADWAY CAPACITY

The project team used Trafficware’s Synchro software to assess current roadway conditions to determine which vehicular approaches are congested during the peak hours. Delay is measured as an average per vehicle per intersection and assessed a letter grade, A through F, to correspond with the length of the delay. An F level of service indicates there is more volume than available capacity. Urban roadways are designed to operate at a level of service (LOS) of D or better. Refer to **[Figure 1.9] Carson Street Existing (2017) Levels of Service** for a summary of existing delay in the vicinity of the station.

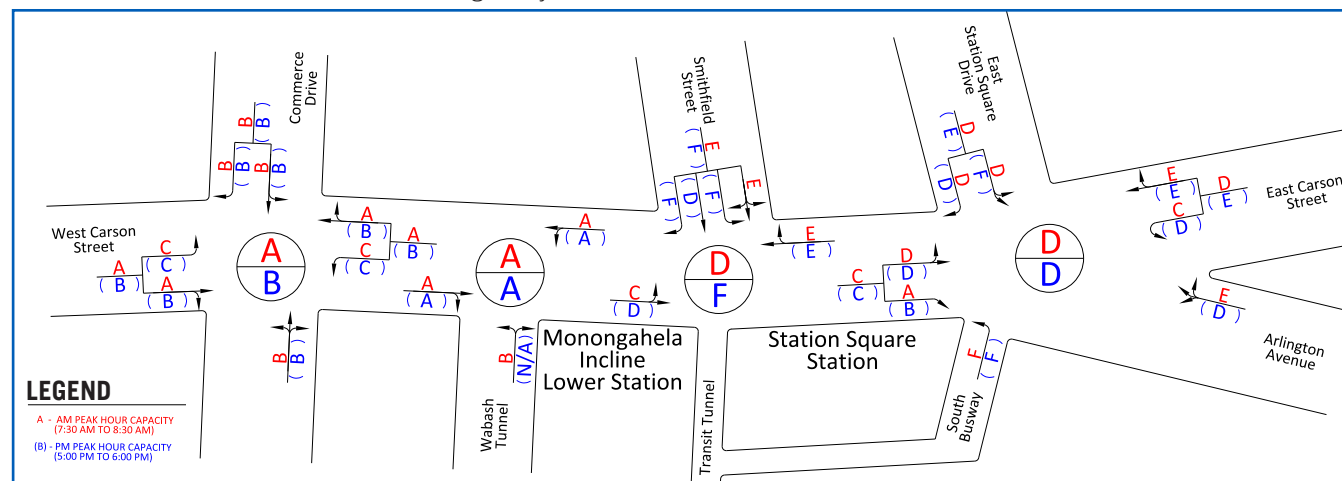

[Figure 1.9] Existing (2017) Levels of Service

The capacity revealed that during the morning peak hour, while all intersections operate at an acceptable level of service of D or better overall, several movements operate at a level of service E. These include westbound East Carson Street and northeast bound Arlington Avenue approaching the intersection with Station Square Drive. Westbound Carson Street’s right turn to the Smithfield Street Bridge and the southbound Smithfield Street Bridge approach also operates at LOS E.

During the PM peak hour, all intersections operate at an acceptable level of service of D or better overall, except for the intersection of Smithfield Street and Carson Street which operates at a failing level of service F. Both the southbound Smithfield Street left and right turns operate at an F level of service during this time. Eastbound Carson Street operates at an E level of service approaching both Station Square Drive and Smithfield Street. The southbound Station Square Drive left turn also operates at an F level of service.

During both peak hours, the South Busway ramp to Carson Street operates at an F level of service, though this is due to a long cycle length and low volume instead of a congestion issue.

The results of the capacity analysis show the need for operational improvements for southbound Smithfield Street and westbound Arlington Avenue and Carson Street. Eastbound Carson Street operates at or below capacity. The Monongahela Incline Lower Station and Station Square LRT and bus station are located along the eastbound (south) side of Carson Street, the side that has the highest pedestrian volume. A future traffic study could determine if space along Carson Street could be reallocated to better serve the needs of pedestrians while maintaining existing levels of service.

TUNNEL CONNECTOR ROAD

Based on discussions with Port Authority staff, the Monongahela Incline is replaced by shuttle service during maintenance periods and is supplemented with shuttle service during peak events, such as Light up Night or Fourth of July. Shuttle service can be confusing to potential riders, since it may not be obvious where to go to catch the shuttle at the temporary stop locations. During peak event periods, Carson Street becomes congested, impeding the ability of efficient shuttle service.

The employee parking lot and maintenance area for the Monongahela Incline is immediately to the east of the lower station. To discourage jaywalking, there is a pedestrian railing with gates separating Carson Street and the south sidewalk; employees opening the gates for parking lot access blocks the sidewalk, which is the only accessible route to the station. Carson Street has a posted speed limit of 35 mph and the employee parking lot is between two signalized intersections. It is difficult for vehicles to enter and exit the lot. In order for riders to think of the incline, T, busway, and bus stops as one transit hub, this operational analysis recommends relocating the employee lot to a better location and developing the area between the LRT and incline as one continuous station.

To address all of these operational concerns, the project team recommends installing a two-lane connector road between the Wabash Tunnel and the Transit Tunnel. The road would pass beneath the Monongahela Incline and add a shuttle stop. One lane of the road could be used for shuttles and maintenance vehicles and the other lane could be used for parallel parking for employees. Such a road would improve station operations in the following way:

- Provide a permanent shuttle stop to eliminate rider confusion during incline maintenance or overcrowding.
- Improve the reliability and efficiency of shuttle service.
- Connect the entire Station Square transit area.
- Eliminate sidewalk conflicts from the employee lot gates.
- Improve maintenance vehicle access for incline maintenance.
- Provide a bus loop if needed for operations.
- Allow space for tourist-oriented uses, such as interpretive signage to give the history of historical transportation structures, such as the Incline, Transit Tunnel, Wabash Tunnel, Panhandle Bridge, and Smithfield Street Bridge, all of which are (or were) used by the Port Authority.

The project team performed conceptual design of the proposed tunnel connector road to determine if there is sufficient horizontal and vertical space. Refer to **[Figure 1.10] Connector Road Conceptual Plan** and **[Figure 1.11] Connector Road Conceptual Profile**.

The conceptual plan shows there is sufficient space to build a connector road behind the Monongahela Incline Lower Station without impacting the station itself or the existing incline support. It would require modification of the existing retaining wall on the south side of the Wabash Tunnel approach. The gated entry to the Wabash Tunnel would need to be relocated. On the Station Square LRT and bus station side, the connector road would require relocating the traffic signal cabinet and overhead trolley electric lines support.

The conceptual profile shows that there would be sufficient clearance to operate vehicles below the Monongahela Incline, with approximately 21 feet of vertical clearance. The connector road would have an approximate 8 percent grade eastbound from the Wabash Tunnel ramp and would transition to around a four and a half percent grade approaching the Transit Tunnel. These slopes meet low-volume roadway standards.

TRANSPORTATION PLANNING

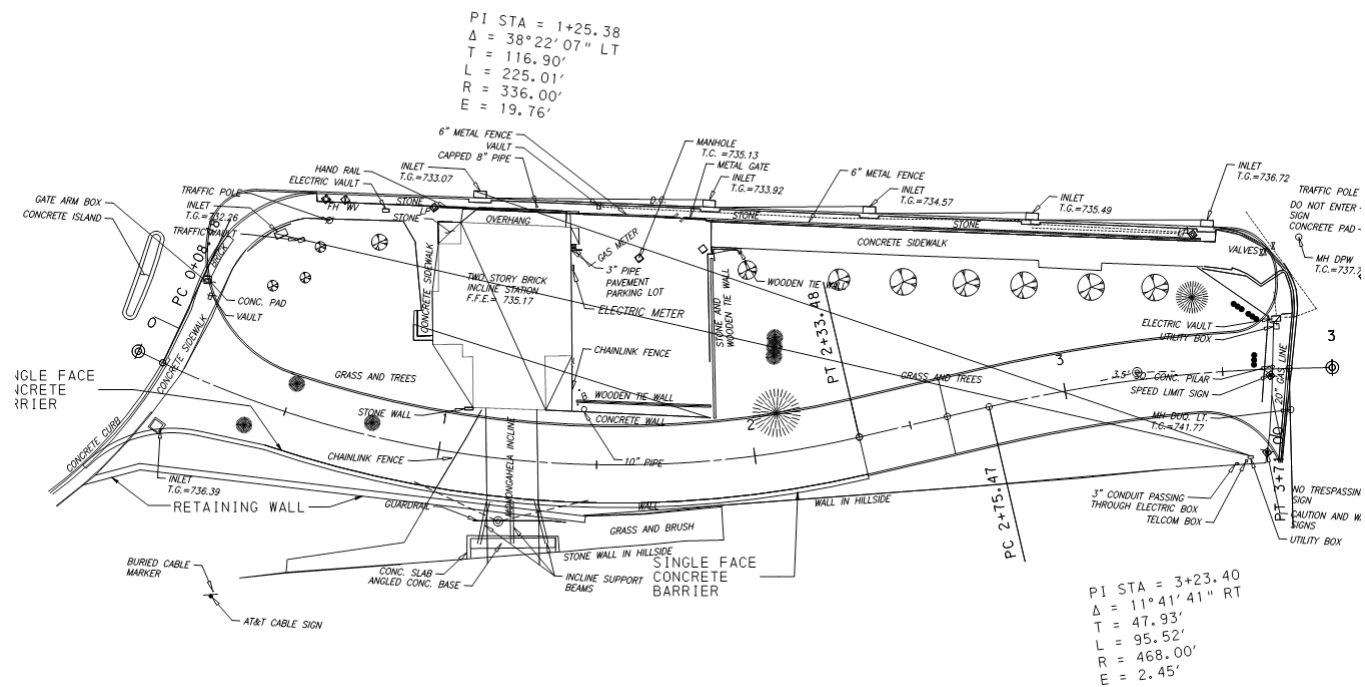

[Figure 1.10] Connector Road Conceptual Plan

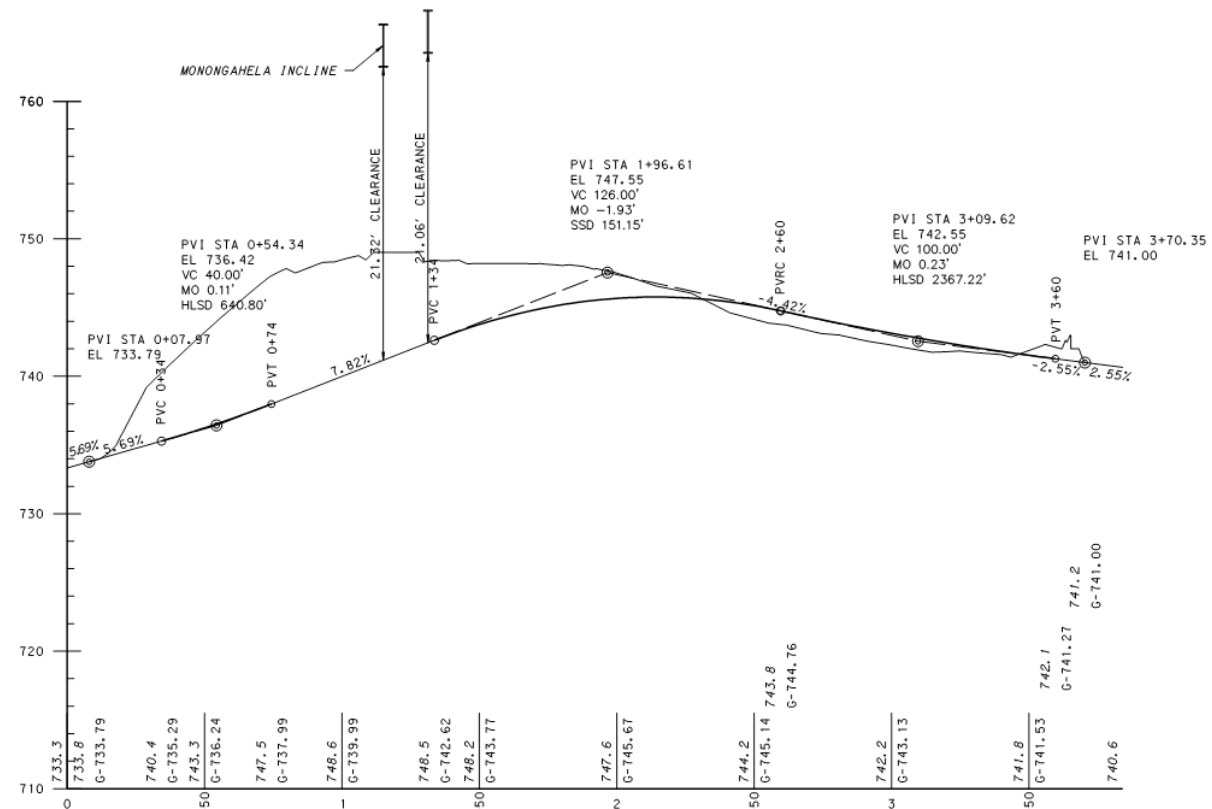

[Figure 1.11] Connector Road Conceptual Profile

By separating the pedestrian realm from the employee and maintenance vehicle realm and improving the reliability of supplemental shuttles, the proposed connector road will improve the functionality and operations of the entire station area.

OPERATIONS ANALYSIS RECOMMENDATIONS

Based on the operational analysis, both the roadways and sidewalks surrounding the Station Square station area are well used by pedestrians and vehicles. Finding the right balance to optimize roadway operations and to increase pedestrian safety and flow will improve the station area experience for all users. Traffic is generally congested in the westbound direction on Carson Street on the (opposite side of the Port Authority's stations) during both the morning and evening peak periods. Eastbound Carson Street volumes approaching Smithfield Street are lower than westbound volumes from Smithfield Street, likely due to the directional Fort Pitt Bridge ramps that provide an alternate route into downtown. Relatively few vehicles turn left onto the Smithfield Street Bridge. The Smithfield Street Bridge is typically congested during the afternoon peak period, but the signal at Carson Street meters traffic. Therefore, eastbound Carson Street runs well operationally, except for the lack of the left turn into Station Square Drive. This volume and capacity analysis shows that any future complete street studies and projects should focus on vehicular capacity for westbound Carson Street and pedestrian capacity and safety for eastbound Carson Street.

There is an employee parking lot on the Monongahela Incline's east side that creates operational problems and serves as a barrier to one integrated station area. Supplemental incline shuttles are limited by traffic congestion along Carson Street during peak events and a lack of rider familiarity since they have no permanent stop. Creating a connector road from the Wabash Tunnel to the Transit Tunnel with one traffic lane and one parking lane would greatly improve operations for pedestrians and employees while better connecting the various separate stations into a larger Station Square transit hub. Therefore, the recommendations presented in this operation analysis will help improve the operational efficiency and usability of the Station Square station area for years to come.

A.2 COMMUNITY ENGAGEMENT

STAKEHOLDER & PUBLIC ENGAGEMENT OVERVIEW

At the outset of the planning process, on April 6, 2017, Port Authority staff and members of the consultant team held a start-up meeting and project area tour. In preparation for the start-up, the consultant team assembled a database of key stakeholders to ensure focused involvement of residents, agency representatives, and other key stakeholders. The database included the following categories:

- Advocacy organizations
- Planning and regional agencies
- Neighborhood organizations
- Key property owners
- Public officials
- Citizens

Two rounds of stakeholder meetings were convened to gather input from key stakeholders. The first round of stakeholder meetings was held on June 7, 2017. Individual stakeholders and organizations identified in the database received invitations. In addition, stakeholder organizations distributed information to their constituents. Follow-up calls were made to stakeholders to encourage attendance and answer any questions about the process. To accommodate stakeholders available in the daytime and those available in the evening, interactive workshops were offered at two times on June 7th, 9:00 to 10:30 AM and 6:30 to 8:30 PM. The meetings were convened at the Sheraton Station Square. At each session, following a brief presentation, participants were invited to visit three stations, focused on these topics:

- Internal connections
- External connections
- Economic development

The second round of stakeholder meetings was convened on October 10, 2017 at Highmark Stadium. Two sessions were offered, from 1:00 to 2:30 PM and 6:30 to 8:00 PM.

Building on input that was gathered at the first round of stakeholder meetings, the consultant team presented concepts for improvements to station access and design, public space, and transit-oriented development. The presentation was followed by a facilitated group discussion.

Supporting Materials

- Stakeholder Database
- Round 1
 - Stakeholder Meeting Flier
 - Meeting Agenda
 - Stakeholder Workshop Meeting Minutes
- Round 2
 - Stakeholder Meeting Flier
 - Meeting Agenda
 - Stakeholder Workshop Meeting Minutes



Community members working together during the first of two public meetings determining the challenges and opportunities of Station Square. The meetings were held at the Sheraton Station Square on June 7, 2017.

Multimodal planning at Station Square



Share your thoughts on Station Square

Starting the Conversation

Station Square is a multimodal transit facility where buses, light rail (the T), and the Monongahela Incline all come together to provide people with options and connections. Port Authority of Allegheny County is creating a plan for this area that will include recommendations for how to make it safer, easier to use, and more attractive.

Part of creating this plan is talking to people who have an interest in the area, including nearby residents, business, and property owners, and riders. To involve those folks, Port Authority's planning team is holding a workshop that is open to public participation.

Woodlawn Room
Sheraton Pittsburgh Hotel at Station Square
Wednesday, June 7th 6:30 to 8:00pm PortAuthority

Fliers for Round 1 of the stakeholder meetings were posted on station bulletin boards, and the Port Authority's website. Local community groups, property owners, and public leaders were also contacted with meeting information.

Multimodal planning at Station Square



We want your feedback on Station Square.

Building upon input gathered from community members in June, Port Authority of Allegheny County is inviting stakeholders to come back together to provide feedback on concepts for improvements to station access, station design, public space, and transit-oriented development. The station area planning process, of which this meeting is a part, has involved looking at Port Authority facilities and property at Station Square as well as conditions in the immediate surrounding area. The resulting plan will recommend improvements that would make it more desirable for people to use Station Square as a multimodal transit facility where buses, light rail (the T), and the Monongahela Incline all come together to provide people with options and connections.

Port Authority's goals for this plan are to identify ways to improve the rider experience and grow ridership and other forms of revenue. Outcomes of planning are intended to be a collaboration of the agency, City, and neighborhood.

Highmark Stadium—510 W. Station Square Drive, Pittsburgh, PA 15219
Tuesday, October 10, 2017
1-2:30 and 6:30-8 p.m.
RSVP to karen@breanassociates.com PortAuthority

Fliers for Round 2 of the stakeholder meetings were posted on station bulletin boards, and the Port Authority's website. Local community groups, property owners, and public leaders were also contacted with meeting information.

COMMUNITY ENGAGEMENT

STATION SQUARE STAKEHOLDER SESSIONS

As part of the station area planning process for Station Square, a stakeholder meeting was held on June 7th and again on October 10th with groups that represent property owners as well as key constituencies that use the system at Station Square. Following is a summary of comments received during the stakeholder discussions.

JUNE 7TH: MORNING SESSION

Other long-term projects

- One Grandview
 - Site has been expensive to develop but plans may be moving again with new owners
 - Participant suggested adding the site to Emerald View Park
- South Hills Junction TRID Study (2010)
 - Mount Washington CDC is working with Hilltop Alliance on South Hills Junction winery project
- Shiloh Street becoming more of a destination
- PennDOT Carson Street TDM project (Smithfield to 33rd)
- Smithfield St Bridge will need rehab soon
 - Current weight limit excludes articulated buses, which would be useful on the PAAC's 51 route (one of the most used)
 - Would be great to have protected bike lanes across bridge
- Future of old Health Dept. building downtown
- Terminal conversion from urban industrial to office space (many more users in the future)
 - Will start in August 2017
 - First phase will be infrastructure
 - A "high line" will be built where there is now parking
- Boggs/Bailey commercial area development
- New trail connection from Crafton/Crafton Heights to bring commuters from Robinson
 - City planning recently approved an easement/riverfront overlay to allow continued access

Trammell Crow Development

- Space currently houses about 1600 spaces, 700-800 of which are used by daily commuters
- No stormwater infiltration on site because of brownfield status

Waterfront as economic development opportunity

- Current conditions
 - Access issues crossing train tracks
 - Port of Pittsburgh recently built dock at Heinz Field. What opportunities are there?
 - Fox Chapel Yacht Club runs leasing in summer
- One participant from Gateway Clipper Fleet shared that during the last bridge rebuild they ran a free shuttle. They had difficulty getting people to use it.
- Opportunities
 - The river cruise market is currently south of the Mississippi
 - Kayaks from venture outdoors
 - Connection to public launch at 18th St

Station Square

- According to Forest City representatives, Station Square is currently 100% leased with some vacancy in the Landmark building.
- Retail has waned in popularity in the past 20 years
- A plan is in progress (not ready to be shared) for the Freight House shops. The vision is inspired by Ponce City Market in Atlanta
- Bradford School is planning to expand
- Not interested in making through street more pedestrian oriented
- Restaurants are doing well despite upcoming turnover

Highmark Stadium

- Around 3000 seat expansion is planned because the Riverhounds moved up in leagues
- Expansion may wrap around existing seats to preserve city view
- There is concern over parking with the expansion
- Youth development academy will be moving to Coraopolis. This will free up time/space for more concerts and events.

Sheraton

- Need better signage to get guests to transit station
- Hotel business has gotten harder in recent years – supply up, demand the same
- Most of the Sheraton's guests are groups (military, business, conferences, social groups)
- 50% of guests who use parking do not need in/out privileges – they use shuttle or walk because the transit system is not intuitive

Ideas

- Could free fare system be expanded to serve Station Square and Highmark Stadium? Who would sponsor?
- Think of the station beginning further out – for example, it would be good to know how to access Emerald Park trails from Station Square
- Signage from the West End to the incline would be helpful
- Access to Healthy Ride from station
- Better connections would encourage economic growth and new residents to move to West End neighborhoods
- Hold more (free or low cost) public events at Station Square to establish it as a destination. One participant noted that she often looks on Facebook for events around the city and rarely sees events in or around Station Square. She cited the examples of Jam on Walnut and yoga outside in Mount Washington. Events like these would bring more young people.

JUNE 7TH: EVENING SESSION

Safety

- It would be useful to have data on pedestrian conflicts around Station Square
- Cycling conditions are unsafe on Smithfield Street Bridge – Many cyclists use the west sidewalk along with a majority of pedestrians. Could cyclists use east sidewalk?
- Sidewalk on south side of Carson at the station is too narrow. The proposed railing would be helpful.
- A raised pedestrian bridge from the Monongahela Incline to the Freight House Shops would take away a lot of pedestrian issues, especially in summer
- Would a refuge island in Carson be useful instead of striping that is currently proposed?

Maintenance

- Brady St railing is in poor condition

Circulation

- There is currently no left turn proposed into the development from Carson. Could that turn be allowed during non-peak hours?
- The current transfer experience between the LRT and buses is not intuitive, discouraging tourists and people from other neighborhoods
- There is an ongoing conversation at the City about reversing the flow of Smithfield and Wood downtown.
- Suggestion – shrink the distance between transfers between modes OR make them read as a single hub
- Suggestion – provide supplementary shuttle service for incline, especially during the busy season

- Proposed access road
 - Could it be a dropoff?
 - Could it be used to loop buses coming off the bridge?
- The primary problem with the station is that the transit is in the wrong place. A more European model would have the station in the middle of development, not on the side.
- Current signal times are based on the time it takes for pedestrians to cross the street. A narrower street will reduce cycle length. Long cycle length is a major complaint about the intersection.

Trammell Crow Development

- How will the development activate Carson?
- What is PAAC's financial commitment to rebuilding the Carson/Smithfield intersection?
- The primary users of Station Square are regional tourists. Focus safety efforts on them.
- Push PennDOT to address the block of Carson to the west of Smithfield instead of stopping at Smithfield. Can the City make safety investments if PennDOT approves?
- The area needs consistent visual language in the street and the station. Design and circulation should be legible, with an eye towards safety especially at night.

COMMUNITY ENGAGEMENT

OCTOBER 10TH: MORNING SESSION

- Is the transition from the Smithfield Street Bridge part of this project or part of the new development? The sidewalk on one side of the bridge is technically part of the trail system, so there are a lot of bicycle-pedestrian conflicts. Bike Pittsburgh would like more work on the bridge-to-trail transition. The current angle is not ideal.
- The radius of the right turn from Carson Street to the bridge is difficult for pedestrian visibility. The proposed 3-second lead time for pedestrians could put them in a dangerous location in the crosswalk by the time cars start turning. Could that radius be tightened?
- Why not expand the sidewalk into the painted hatch section shown in front of the LRT station?
- Could there be a crosswalk connecting the incline and the Belgian block walkway on the northern side of Carson? Could that Belgian block area be widened?
- Will the inbound bus stop on Smithfield Street impede traffic?
- The protected left turn and lane reductions are both great proposals. Could there be a protected right lane onto the bridge?

OCTOBER 10TH: EVENING SESSION

- I use the incline and LRT connection regularly. I'm concerned about the bus-pedestrian conflicts coming off of the bridge to the incline and crossing from the incline to the T.
- There should be better service between the Duquesne and Monongahela inclines.
- I am a reverse commuter between the Terminal Building and Downtown. Bus service can be slow during rush hour. I'm concerned about the additional time it will take to walk between the bus stop and LRT station with the bus stop moved further up the bridge.
- I'd like to see more of a connection for the Mount Washington community in addition to the incline.
- There is often a line for the incline. That sidewalk should be wider.
- There should be seating at the Smithfield Street bus stop.
- Can there be a staircase from the Smithfield Street bus stop to Station Square shops?
- The new trail connection on the other side of the bridge is well under construction, so it would be nice for the display materials to show that.
- The incline house door swings out, which seems unsafe.
- City Planning Commission had a hearing today on the City's Climate Action Plan. I would like to see more greening consistent with the City's plan.
- There should be more public art in the discussion here. There are some good opportunities to use light or other media (ex – TBD under Ft Duquesne Bridge since 2015).
- Bus shelters should have phone charging stations or other 21st century amenities.

Port Authority Transit Oriented Development: Invited Stakeholders - Station Square	
Advocacy Organizations	Committee for Accessible Transportation (CAT)
	Disabilities Law Project
	Three Rivers Center for Independent Living
	Healthy Ride
	Green Building Alliance
	Bike Pittsburgh
	Pittsburghers for Public Transit
	Visit Pittsburgh
	Tree Pittsburgh
	Riverlife
Pittsburgh Community Reinvestment Group	
Planning and Regional Agencies	Allegheny County Economic Development
	Pittsburgh Department of City Planning
	Pittsburgh Department of Mobility and Infrastructure
	Allegheny Conference on Community Development
	Pittsburgh Water and Sewer Authority
	Urban Redevelopment Authority of Pittsburgh
	Pittsburgh Department of Mobility and Infrastructure
	DPW, Bureau of Transportation and Engineering
Office of the County Executive	
Southwestern Pennsylvania Commission	
Citizens	Beechview Area Concerned Citizens
Community Organizations	South Side Chamber of Commerce
	South Side Community Council
	Brashear Association (convenes South Side Planning Forum)
	Pittsburgh Downtown Partnership
	Mount Washington CDC
	South West Pittsburgh CDC
	Pittsburgh Downtown Community Development Corporation
	Forest City Enterprises
Trammell Crow Company	
Key Property Owners	Pittsburgh History and Landmarks Foundation
	Sheraton Hotel at Station Square
	Gateway Clipper Fleet
	McKnight Realty Partners (Terminal Way/High Line)
	Pittsburgh Riverhounds/Highmark Stadium
	City of Pittsburgh District 3
Public Officials	City of Pittsburgh District 2
	City of Pittsburgh District 6
	Allegheny County Council District 12
	Allegheny County Council District 13
	Office of Mayor
	Office of County Executive

Listed are the identified stakeholders for the Station Square General Planning Services meetings.

PortAuthority