



**PORT AUTHORITY OF ALLEGHENY COUNTY
LIGHT RAIL TRANSIT
STATION DESIGN GUIDELINES**

V.4.0 7/20/18

ACKNOWLEDGEMENTS

Port Authority of Allegheny County (PAAC) provides public transportation throughout Pittsburgh and Allegheny County.

The Authority's 2,600 employees operate, maintain, and support bus, light rail, incline, and paratransit services for approximately 200,000 daily riders.

Port Authority is currently focused on enacting several improvements to make service more efficient and easier to use. Numerous projects are either underway or in the planning stages, including implementation of smart card technology, real-time vehicle tracking, and on-street bus rapid transit.

Port Authority is governed by an 11-member Board of Directors – unpaid volunteers who are appointed by the Allegheny County Executive, leaders from both parties in the Pennsylvania House of Representatives and Senate, and the Governor of Pennsylvania. The Board holds monthly public meetings.

Port Authority's budget is funded by fare and advertising revenue, along with money from county, state, and federal sources. The Authority's finances and operations are audited on a regular basis, both internally and by external agencies.

Port Authority began serving the community in March 1964. The Authority was created in 1959 when the Pennsylvania Legislature authorized the consolidation of 33 private transit carriers, many of which were failing financially. The consolidation included the Pittsburgh Railways Company, along with 32 independent bus and inclined plane companies.

By combining fare structures and centralizing operations, Port Authority established the first unified transit system in Allegheny County.

Participants

Port Authority of Allegheny County would like to thank agency partners for supporting the Light Rail Transportation Station Guidelines, as well as those who participated by dedicating their time and expertise.

These guidelines were developed by the Port Authority of Allegheny County in collaboration with CDM Smith and Studio for Spatial Practice (SfSP). All maps and graphics were created by CDM Smith and SfSP.

**Port
Authority**

CDM Smith

**studio for
spatial practice**

Published April 2018.

CONTENTS

1.	SETTING THE STAGE	4			
	Why This Document?	6			
	LRT System & Facilities Overview	7			
	LRT System Map	8			
	How To Use This Document	9			
2.	STATION CATEGORIZATION	10			
	Categorization Methodology	12			
	Station Category Matrix	14			
	Station Categories	15			
3.	LRT STATION DESIGN GUIDELINES	20			
	3.1 General Principles:	22			
	Customer & Staff Comfort	24			
	Visual Consistency	26			
	Coherent Site Design	28			
	Durability & Maintenance	30			
	3.2 Primary Materials:	32			
	Concrete	34			
	Metals	36			
	Paint	38			
	Color Palette	39			
	Translucent/Transparent Materials	40			
	3.3 Common Elements:	42			
	Platforms	44			
	Platform Canopies	46			
	Walkways, Ramps, & Stairs	48			
	Guardrails, Handrails, & Gates	50			
	At-Grade Track Crossing	52			
	Between Car Barriers	54			
	Salt Storage	55			
	3.4 Station Property:	56			
	Public Entry Plaza	58			
	Site Lighting	60			
	Planting Design	62			
	Public Art	66			
	Adjoining Bus Shelters	68			
	Bicycle Parking	70			
	Bike-share Station	72			
	Passenger Drop-Off Area	74			
	Retail Kiosk	76			
	Commuter Parking Connection	78			
	3.5 Platform Amenities:	80			
	Seating	82			
	Leaning Bars	84			
	Platform Lighting	86			
	Windscreens	88			
	Trash & Recycling Receptacles	90			
	Advertising	91			
	Public Art	92			
	3.6 Technology & Signage:	94			
	Signage	96			
	- Identity Signage	98			
	- Station Identification Signage	99			
	- Directional Signage	100			
	- ADA Signage	101			
	Ticket Vending Machines	102			
	Information Display Units	104			
	Validators	106			
	Call Box / Emergency Buttons	107			
	Patron Notice Boards	108			
	Public Address System	110			
	Surveillance Cameras	111			
	Real-Time Arrival Information	112			
	Technology Integration	113			
4.	APPENDIX	114			
	4.1 Design Details and Product Data				
	Concrete Repair	116			
	Bench Removal	120			
	Guardrail Mounting	121			
	Bench Detail	122			
	Guardrail Detail	123			
	Color Application	125			
	4.2 Flashcards				
	How To Use Flashcards	128			
	IMAGE INDEX & CREDITS	132			

1



SETTING THE STAGE



WHY THIS DOCUMENT?

The Design Guidelines for the Light Rail Transit (LRT) system stations is an internal document for use by various departments of the Port Authority of Allegheny County (Port Authority or PAAC). This document is a reference guide to inform station improvements, whether it be repair, replacement, upgrade of an existing station, or design of a new station. The intention of the guidelines document is to become the basis of design decisions for all stations along Authority's LRT fixed guideways. This initiative has been implemented in coordination with the Station Improvement Program (SIP), the goals of which are to improve the Authority's image, increase ridership and revenue, and create opportunities for Transit Oriented Development (TOD).

The Design Guidelines were developed through multiple brainstorming meetings, story-boarding sessions, and three internal workshops. Each workshop invited representatives from all relevant departments throughout the Authority. The expertise of these representatives regarding our LRT system created the foundation for these guidelines. That expertise was combined with best practices in transit facilities to establish the principles of design in the final Design Guidelines.

Applying the design principles established in this document will create a cohesive design for the LRT fixed guideway, giving every station a common design vocabulary. While establishing this common vocabulary, the implementation remains flexible enough to allow each individual station to respond to its own context. By standardizing certain elements, and including best practices for repairing or replacing those elements, these guidelines contain efficiencies for maintenance and materials, and establish design goals for all stations.



Workshop #1, October 23, 2017



Workshop #2, December 14, 2017

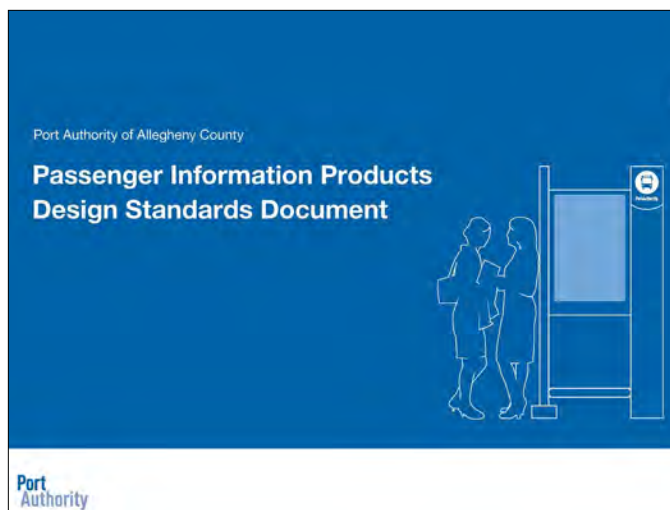

Recent strategic initiatives have created a range of planning guidelines for improving the Port Authority system. Left: *Transit-Oriented Development Guidelines* lays out a road map and best practices to most effectively utilize station property with the goal of increased ridership, improved land use, and integrated sustainability. Right: *Passenger Information Products Design Standards Document* sets guidelines for wayfinding, signage, text, and colors for the network.

LRT SYSTEM & FACILITIES OVERVIEW

The Port Authority's Light Rail Transit (LRT) system, also known as "the T," links downtown Pittsburgh with Pittsburgh's southern neighborhoods and southern suburbs. Although the LRT system has served the ridership community for 30 years, its design and construction has occurred in three major phases.

The Stage I system, comprised of the Downtown Subway, the Mt. Lebanon –Beechview Line, and the spur to South Hills Village, opened for service in 1987. The 10.5-mile Stage I LRT Project involved replacement of downtown streetcar trackage with a new subway, reconstructing the trolley line to LRT standards, construction of the South Hills Village rail car maintenance and storage facility, acquisition of 55 light rail vehicles (LRVs), construction of new park-and-ride lots, and installation of new catenary and signal systems. It is currently identified as the Red Line.

Under the Stage II LRT Project, the 5-mile Overbrook Line was completely rebuilt, 28 LRVs were added to Port Authority's rail fleet, new park-and-ride lots were built, a new catenary and signal system was installed, and further improvements were made to the Stage I system. The rebuilt Overbrook Line opened in 2004 and it is now part of the Blue Line service.

The North Shore Connector project extended the LRT system 1.2 miles from Gateway Station in downtown Pittsburgh to the North Shore. The project involved tunneling under the Allegheny River and through North Shore west of PNC Park, building a section of elevated alignment to the terminus next to the Carnegie Science Center and Heinz Field, and construction of the Allegheny and North Side stations and a new Gateway Station. It opened in 2012 and is served by both Red Line and Blue Line trains.

With design and construction occurring over three major phases within the past 30 years, the LRT system lacks standardization. The lack of standardization goes beyond look and amenities. It extends to the ability for the Port Authority to efficiently operate and maintain the LRT system.

This document focuses on the portion of the LRT system beyond the First Avenue Station in Downtown Pittsburgh. These guidelines cover 47 LRT stations includes the following lines:

- Red line – starts at South Hills Junction, follows Rt. 19, and ends at Overbrook Junction
- Blue line – starts at South Hills Junction, follows Rt. 51 & 88, and ends at Library end of line
- Combined Red Line and Blue Line between from South Hill Village to St. Anne's and First Avenue to South Hills Junction.



The LRT system contains highly diverse station facilities.
Top: Gateway Station
Middle: Dormont Junction
Bottom: West Library Station

LRT SYSTEM MAP

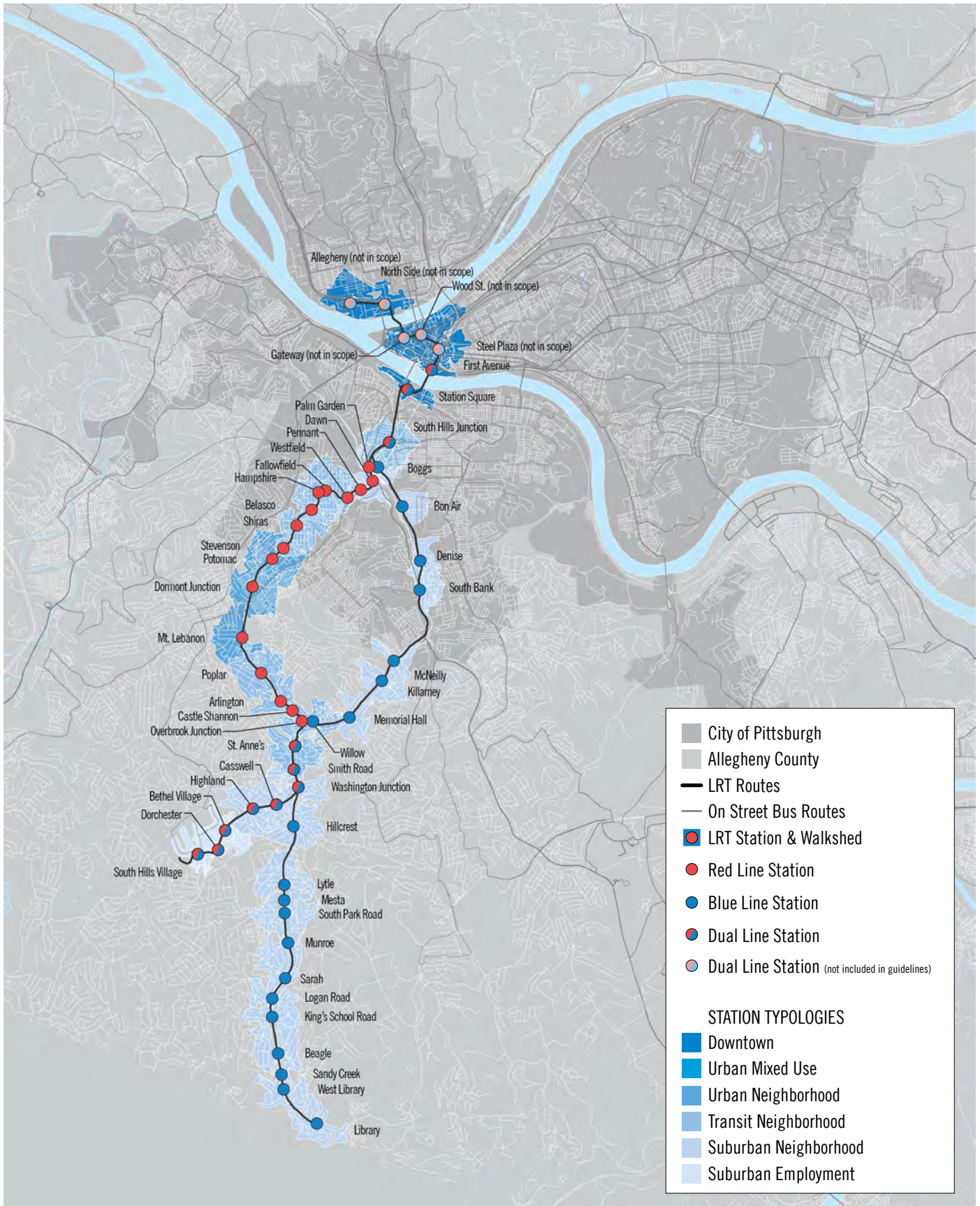

HOW TO USE THIS DOCUMENT

The Design Guidelines were developed for internal use by all Authority departments, with a particular focus on Engineering and Design, Station Maintenance, and Marketing. This document was also developed to be given to Authority consultants for use on station and station-related upgrade and design projects along the LRT fixed guideway.

1. Identify the station category.

The first step in developing the guidelines was to understand the many types of stations in the Authority's system. This section establishes the category types for each station to appropriately target recommendations to groups of stations. By utilizing existing data and ridership potential, each station was placed into a category for design. The methodology and subsequent categorization of station is explained in detail in Chapter 2 of this document.

STATION CATEGORY MATRIX

Station	Station Type	Category	Platform	Canopy	Structure	Access	Notes
Altoona	Station	1	1	1	1	1	
Beaver Falls	Station	1	1	1	1	1	
Chillicothe	Station	1	1	1	1	1	
Concord	Station	1	1	1	1	1	
Delaware	Station	1	1	1	1	1	
Easton	Station	1	1	1	1	1	
Franklin	Station	1	1	1	1	1	
Greenville	Station	1	1	1	1	1	
Highland	Station	1	1	1	1	1	
Lebanon	Station	1	1	1	1	1	
London	Station	1	1	1	1	1	
Madison	Station	1	1	1	1	1	
Marion	Station	1	1	1	1	1	
Meridian	Station	1	1	1	1	1	
Millersburg	Station	1	1	1	1	1	
Northwood	Station	1	1	1	1	1	
Paris	Station	1	1	1	1	1	
Rockwell	Station	1	1	1	1	1	
Shelby	Station	1	1	1	1	1	
Union	Station	1	1	1	1	1	
Waverly	Station	1	1	1	1	1	
Weston	Station	1	1	1	1	1	
York	Station	1	1	1	1	1	

CATEGORY 1

High Long Platform + High Mobility + High-Event Potential

Station: • Park Station • Union Station • South Hill Station

Station images showing platform, canopy, and interior views.

2. Identify the guidelines section of desired element.

Elements are categorized by six sections: General Principles, Primary Materials, Common Elements, Station Property, Platform Amenities, or Technology & Wayfinding. Each element describes:

- Existing : condition, type, material, challenges and opportunities that exist.
- Repair : recommended maintenance.
- Replace : lifespan when replacement is required.
- New : element placement, orientation, and number.

TICKET VENDING MACHINES

EXISTING

Review existing ticket vending machines for condition, type, material, and placement. Identify any issues or opportunities for improvement.

REPLACE

Replace existing ticket vending machines with new models that meet the Authority's requirements for accessibility, durability, and security.

NEW

Install new ticket vending machines in strategic locations to improve passenger convenience and reduce wait times.

Images showing existing and new ticket vending machines in station environments.

3. Apply Design Details and Product Data in the appendix.

In many cases, specific design details or products have been established to create a cohesive design that reinforces the identity of Port Authority stations while simplifying design and maintenance for agency staff. These details and product data sheets can be found in the Appendix. The items in the Appendix are a reference for maintenance replacement and should serve as the foundation for construction documents for design projects.

REPAIR TYPE M: EPOXY JOINT/CRACK REPAIR

DETAIL D

CONCRETE/ANODIZED BENCH REMOVAL

DETAIL E

Technical drawings showing cross-sections of concrete repair and bench removal with annotations and dimensions.

4. Utilize Flashcards in the appendix for easy reference.

In addition to the Appendix, this document also includes design flashcards, intended to be a quick reference to station design concepts. The flashcards are organized in two ways:

- By canopy type
- By element

1.02 STATION CANOPY : CURVE

SYSTEMS

High Long Platform + Category 10 + 11

DETAILS

Technical drawing showing the curve of a station canopy with various details and dimensions.

MATERIALS

Table listing materials and their specifications:

Material	Specification
Aluminum	6061-T6
Steel	A36
Concrete	3000 psi
Paint	Primer and Topcoat

2.





STATION CATEGORIZATION

CATEGORIZATION METHODOLOGY

Approach

The Port Authority LRT system is highly diverse, with stations of different sizes, different levels of ridership, different ages, and located in different types of communities. To give appropriate guidance, the stations have been organized into categories to account for this system diversity. While many design principles and guidelines apply to all stations, the station categories allow recommendations, particularly for station amenities, to vary by size and intensity of use. Although there are certain elements required at each station, as passenger counts increase, the numbers and types of amenities should increase to appropriately accommodate the passengers. The categorization methodology also provides a formula for re-categorizing stations based on future passenger growth.

The categorization methodology includes the following factors:

- Platform Height (high or low)
- Platform Length (long or short)
- Station Ridership
- Passenger Growth Potential

The basic station category is established using the platform height, length, and existing ridership. Potential for future ridership growth is then factored in to account for future change. Over time, it is expected that unforeseen growth, reduction in demand, or transit-oriented development (TOD) may cause stations to shift categories, allowing for different levels of investment and prioritization. The decision tree on the following page illustrates this process.

Platform Height

Platform height is used as the first step in categorizing the stations. The majority of stations have a high platform 15 inches above the rail, allowing for accessible entry into LRVs. Some stations in the system have a low or at-grade boarding condition that is not currently ADA accessible. The methodology allows for the recommendation of high platforms at locations with high ridership and high passenger growth potential.

Platform Length

Stations are further distinguished by their platform length. Around half of the stations have a long high-capacity platform over 100 feet in length, allowing simultaneous entry or exit into multiple cars. The remaining stations have a short platform of 20 to 25 feet.

Station Ridership

Observed peak boarding and alighting ridership counts are used to further distinguish the high long platform stations into three separate categories with differing intensities of use. It was determined that using total passengers per day was the most appropriate method to differentiate between the station categories. This provides the overall use of the station. The passenger peak times aligned with the total passengers per day within each category (for instance, the stations with high passenger counts per day had the higher counts of passengers during peak hours). Therefore, the peak-hour passenger count at any station did not vary enough to warrant moving a station to another category.

Riders are the most critical element in the system. As such, ridership is crucial, and the level of investment and amenities should be based on the passengers served.

Passenger Growth Potential

Passenger growth potential (PGP) anticipates the possibility of stations shifting categories due to future changes in ridership resulting from adjacent TOD, intermodal capacity, and future demographic changes. The PGP metric is comprised of a combination of:

- TOD Potential – Those stations that were defined in the TOD guidelines as having potential for increased development density
- Service Transfer – Stations with multi modal transfers
- Park and ride – Stations with park and ride lots
- Walkshed Growth – Stations with the zoning potential for increased walkshed population density

The PGP metric anticipates possible shifts to higher (and in some cases lower) ridership that could shift a station from one category to another as ridership, demographics, and TOD investment change over time.

STATION CATEGORY DECISION TREE

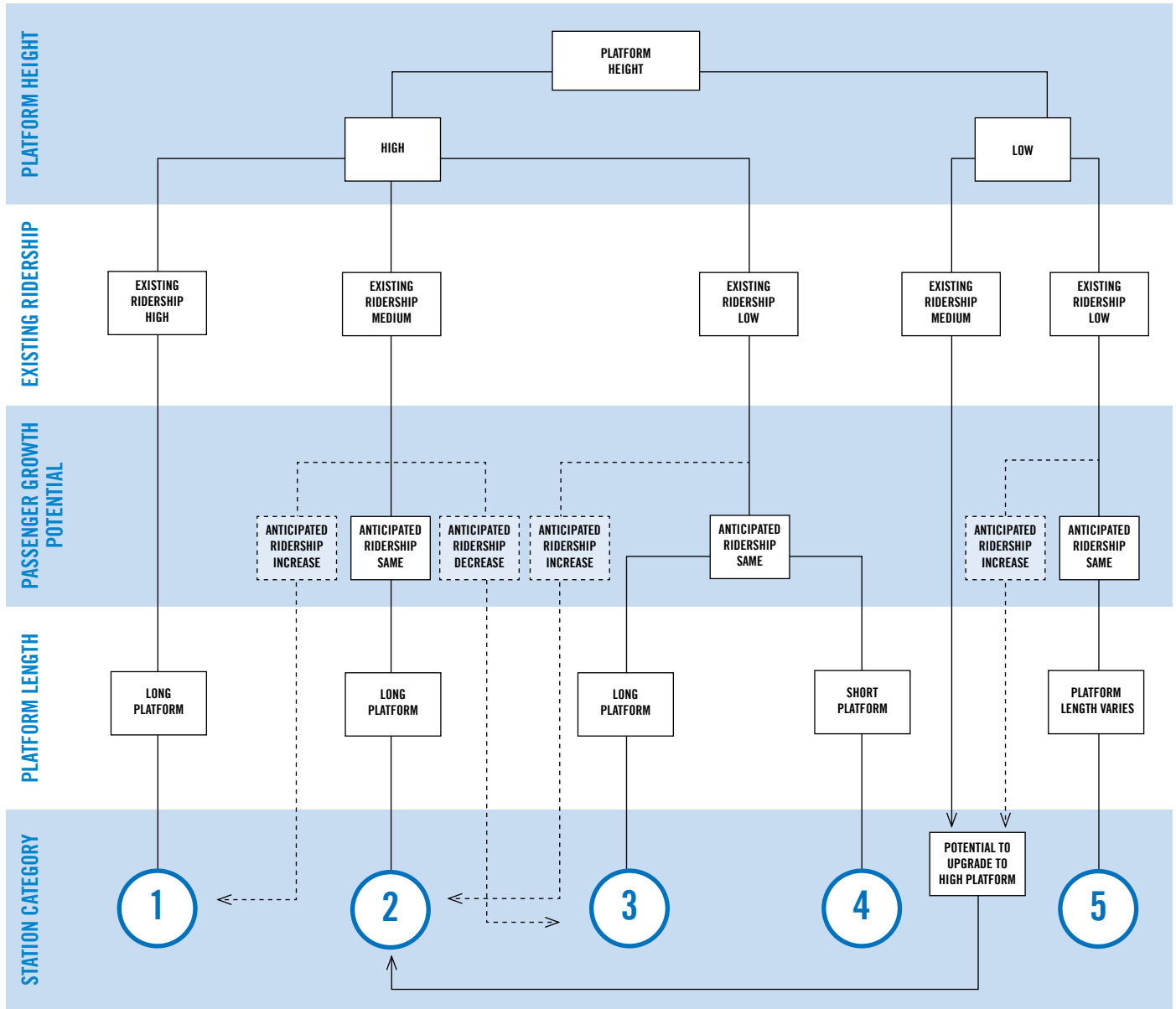

CATEGORY 1
High Long Platform
High Ridership
High Growth Potential



CATEGORY 2
High Long Platform
Medium Ridership
Medium Growth Potential



CATEGORY 3
High long platform
Low Ridership
Low Growth Potential



CATEGORY 4
High Short Platform
Low Ridership
Low Growth Potential



CATEGORY 5
Low Platform
Low Ridership
Low Growth Potential



STATION CATEGORY MATRIX

Station	Service Line	Station Category	Platform Height	Platform Length	Riders Per Day	Notes		
						TOD Type (from Transit-Oriented Development Guidelines)	Service Transfer	Park & Ride
Arlington	Red Line	5	Low	Long	341	Transit Neighborhood	No	No
Beagle	Blue Line	5	Low	Both	50	Suburban Neighborhood	No	No
Belasco	Red Line	5	Low	Short	239	Transit Neighborhood	No	No
Bethel Village	Blue and Red Lines	5	Low	Long	176	Suburban Employment	No	No
Boggs	Blue Line	3	High	Long	71	Suburban Neighborhood	No	No
Bon Air	Blue Line	3	High	Long	118	Suburban Neighborhood	No	No
Casswell	Blue and Red Lines	5	Low	Short	57	Suburban Neighborhood	No	No
Castle Shannon	Red Line	2	High	Long	998	Transit Neighborhood	Yes	Yes
Dawn	Red Line	5	Low	Long	31	Suburban Neighborhood	No	No
Denise	Blue Line	3	High	Long	189	Suburban Neighborhood	No	No
Dorchester	Blue and Red Lines	5	Low	Long	112	Suburban Employment	No	No
Dormont Junction	Red Line	2	High	Long	831	Urban Neighborhood	Yes	Yes
Fallowfield	Red Line	2	High	Long	520	Transit Neighborhood	No	No
First Avenue	Blue and Red Lines	1	High	Long	3569	Downtown	No	Yes
Hampshire	Red Line	5	Low	Short	315	Transit Neighborhood	No	No
Highland	Blue and Red Lines	5	Low	Long	93	Suburban Neighborhood	No	No
Hillcrest	Blue Line	5	Low	Short	86	Suburban Neighborhood	No	No
Killarney	Blue Line	2	High	Long	325	Suburban Neighborhood	No	No
Kings School Road	Blue Line	5	Low	Long	103	Suburban Neighborhood	No	No
Library	Blue Line	2	High	Long	1040	Suburban Neighborhood	No	Yes
Logan Road	Blue Line	5	Low	Short	104	Suburban Neighborhood	No	No
Lytle	Blue Line	2	High	Long	775	Suburban Neighborhood	No	Yes
McNeilly	Blue Line	3	High	Long	207	Suburban Neighborhood	No	No
Memorial Hall	Blue Line	2	High	Long	1811	Suburban Neighborhood	No	Yes
Mesta	Blue Line	5	Low	Long	52	Suburban Neighborhood	No	No
Monroe	Blue Line	5	Low	Short	49	Suburban Neighborhood	No	No
Mt. Lebanon	Red Line	2	High	Long	1076	Urban Neighborhood	Yes	Yes
Overbrook Junction	Blue and Red Lines	4	High	Short	234	Transit Neighborhood	No	No
Palm Garden	Red Line	5	Low	Long	188	Suburban Neighborhood	Yes	No
Pennant	Red Line	5	Low	Long	25	Suburban Neighborhood	No	No
Poplar	Red Line	5	Low	Long	235	Transit Neighborhood	No	No
Potomac	Red Line	2	High	Long	1015	Urban Neighborhood	No	Yes
Sandy Creek	Blue Line	5	Low	Short	51	Suburban Neighborhood	No	No
Sarah	Blue Line	5	Low	Long	60	Suburban Neighborhood	No	No
Shiras	Red Line	5	Low	Short	290	Transit Neighborhood	No	No
Smith Road	Blue and Red Lines	5	Low	Short	84	Suburban Neighborhood	No	No
South Bank	Blue Line	3	High	Long	183	Suburban Neighborhood	No	No
South Hills Junction	Blue and Red Lines	2	High	Long	1076	Transit Neighborhood	Yes	No
South Hills Village	Blue and Red Lines	1	High	Long	3422	Suburban Employment	Yes	Yes
South Park Road	Blue Line	5	Low	Short	123	Suburban Neighborhood	No	No
St. Anne's	Blue and Red Lines	5	Low	Long	877	Transit Neighborhood	Yes	Yes
Station Square	Blue and Red Lines	1	High	Long	2380	Downtown	Yes	No
Stevenson	Red Line	5	Low	Long	210	Urban Neighborhood	No	No
Washington Junction	Blue and Red Lines	2	High	Long	1526	Suburban Neighborhood	No	Yes
Westfield	Red Line	5	Low	Long	347	Transit Neighborhood	No	No
West Library	Blue Line	4	High	Short	294	Suburban Neighborhood	No	Yes
Willow	Blue Line	2	High	Long	782	Transit Neighborhood	No	No

CATEGORY 1



First Avenue



Station Square



South Hills Village



South Hills Village

High Long Platform + High Ridership + High Growth Potential

This category includes elevated concrete platforms more than 100 feet long; the average daily ridership is high; and the anticipated PGP potential is high.

These stations are the largest facilities south of the Central Business District. The nature and design of the stations vary due to the location, prominence, and context. They each contain separated concrete platforms with built-in seating. One of the stations is associated with a park and ride garage, while the other stations have public parking in the vicinity.

Stations

- First Avenue
- South Hills Village
- Station Square

CATEGORY 2



Potomac



Mt. Lebanon



Fallowfield



Lytle

High Long Platform + Medium Ridership + Medium Growth Potential

This category includes elevated concrete platforms more than 100 feet long; the average daily ridership is medium; and the anticipated PGP potential is medium.

These stations are a mix of Stage I and Stage II facilities. The nature and design of the stations vary, including both separated and center mounting platforms. Some of the stations are also associated with a park and ride lot. Several of the stations are based on a prototypical design matching Category #3 stations and include identical canopy structures.

Stations

- Castle Shannon
- Dormont Junction
- Fallowfield
- Killarney
- Lytle
- Library
- Memorial Hall
- Mt. Lebanon
- Potomac
- South Hills Junction
- Washington Junction
- Willow

CATEGORY 3



Boggs



Bon Air



McNeilly



Denise

High Long Platform + Low Ridership + Low Growth Potential

This category includes elevated concrete platforms more than 100 feet long; the average daily ridership is low; the anticipated PGP potential is low.

These stations are newer stations along the Stage II line. As the terrain is hilly, many of the separated concrete platforms are accessed by lengthy concrete ramps. Some of the stations are associated with a park and ride lot. All the stations are based on a prototypical design and include identical canopy structures. The outbound and inbound platforms are mirror images, containing a flat concrete waiting area, a curved overhead canopy with integral seating and glazed wind screens, site amenities, and indirect lighting on concrete posts having two different textures. The flat area of both platforms, approximately 8 feet wide, is constructed of following components: a concrete slab with control joints aligning with the base of the canopy framing columns; a dark-colored brick paver approximately 6" x 12"; and a light color 24" x 24" truncated warning pavers. The overhead canopy includes steel

framing, supported by offsetting concrete columns, and carries a perforated ceiling and narrow skylights aligned with the columns. The back of the canopy area includes a glazed wind screen supported by aluminum storefront type framing; the base sections have badly damaged finishes. One metal bench for seating is supported by concrete columns at each end of the canopy; there are two benches total at each platform.

Stations

- Boggs
- Bon Air
- Denise
- McNeilly
- South Bank

CATEGORY 4



Overbrook Junction



Overbrook Junction



West Library Station



West Library Station

High Short Platform + Low Ridership + Low Growth Potential

This category includes elevated concrete platforms 20 to 25 feet long; the average daily ridership is low; and the anticipated PGP potential is low.

These stations are older stations along the Stage I line. The short, separated concrete platforms (less than 20 feet long) are accessed by lengthy concrete ramps. Overbrook Junction is a transfer station between the Stage I and Stage II lines. Overbrook has a canopy structure, but West Library only has a bus shelter for cover.

Stations

- Overbrook Junction
- West Library

CATEGORY 5



St. Anne's



Beagle



Dawn



Shiras

Low Platform + Low Ridership + Low Growth Potential

This category includes at-grade concrete platforms of varying configurations and lengths; the average daily ridership is low; and the anticipated PGP potential is low. Currently, one station has ridership above 300 passengers per day (St. Anne's station). Under this scenario, the station could be considered for an upgrade to a high platform.

These stations are typically older stations along the Stage I line. They are typically in neighborhoods and are not associated with park and ride lots. They have several platform types, including long and short concrete platforms, but all stations have separated platforms. Some stations have canopies with a leaning rail, others have bus shelters, and some have no passenger covering element.

Stations

- Arlington
- Beagle
- Belasco
- Bethel Village
- Casswell
- Dawn
- Dorchester
- Hampshire
- Highland
- Hillcrest
- Kings School Road
- Logan Road
- Mesta
- Monroe
- Palm Garden
- Pennant
- Poplar
- Sandy Creek
- Sarah
- Shiras
- Smith Road
- South Park Road
- St. Anne's
- Stevenson
- Westfield

3.





LRT STATION DESIGN GUIDELINES

GENERAL PRINCIPLES

Overview

The built environment has a significant impact on how riders perceive their journeys, and contributes to their overall happiness and PAAC's reputation. The general principles set maintenance and design goals for future improvements to the PAAC LRT system.

The principles should be applied to all station improvement projects, from small repairs to new station construction. They should drive decision-making, and be used as a checklist throughout the design process. Applying the design principles from the start of each project will ensure high-quality design uniformity, and avoid unnecessary project delays. The entire project team --including PAAC staff, consultants, and contractors --should adopt these design principles early on to improve coordination and decrease confusion.

The 4 general principles are:

- Customer and Staff Comfort
- Visual Consistency
- Coherent Site Design
- Durability and Maintenance



Boston's MBTA Green Line, Longwood Station,
Low Platform



San Francisco's Muni Metro J Church Line, Church St. & 14th St. Station,
Low Platform



Pittsburgh's PAAC Allegheny Station, High Platform, Central Loading

Customer & Staff Comfort

Well cared for and tidy spaces make riders feel more comfortable and safe, positively reflecting on the overall PAAC brand and service.

Visual Consistency

Station maintenance, repair and redesign efforts should strive to increase visual consistency across the PAAC LRT system. Future station improvements should seek to increase the visual consistency the outlying Red Line and Blue Line stations as a general guiding principle.

Coherent Site Design

The area surrounding the station property has an equally important influence on the PAAC brand. In addition to providing the front face of the station to a passerby, the site design also connects the station to the existing surrounding public realm.

Durability & Maintenance

Well-designed stations consider the life-cycle of existing and new materials and products, while also designing in flexibility to allow stations to better respond to future challenges and opportunities.

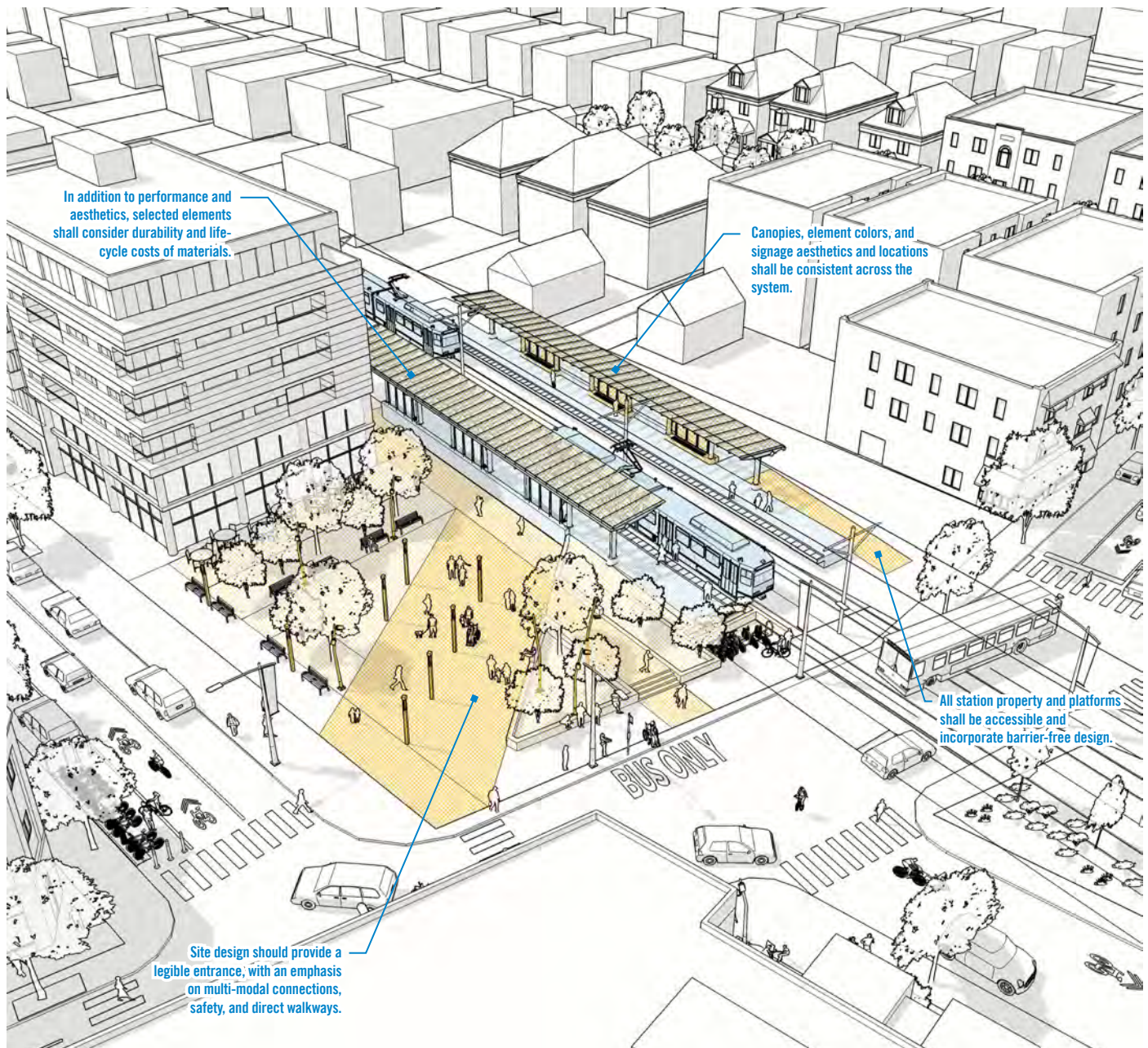

CUSTOMER & STAFF COMFORT

Well cared for and tidy spaces make riders feel more comfortable and safe, positively reflecting on the PAAC overall brand and service.

Particular attention should be placed towards riders who have specific needs --groups such as families, the elderly, and those with disabilities. Universal design principles should be incorporated at all stations.

Customer comfort should be addressed at all stages of a rider's journey. From actively riding the system to waiting for train arrivals, customers gauge their ride experience in totality.

In addition, well-designed stations support the efficiency of staff and crew to carry out their duties, reducing confusion and stress caused by inherent station design flaws that can hinder the use of equipment and tools.

For staff, station design also should allow for the appropriate use and storage of equipment throughout the different seasons of the year.

Public Safety

Safety is a primary consideration of the user experience. Stations and platforms should offer high-visibility and transparency; use of translucent materials, pedestrian-scale lighting, and security equipment should be well-integrated into the design.

For stations located out-of-sight of the public street or far away from other transit riders, special care should be made to create unobstructed sight lines between the platform, the public right-of-way, and the areas in-between. Walkways linking the platform to the public sidewalk should be well-lit as well, with ticket and information kiosks featured with distinct safety lighting.



New entry & lighting at Gateway Station, Pittsburgh

Accessibility

Transit is an essential regional asset, and people of all ages and abilities must be accommodated when planning and designing new station improvements. Improvements to existing stations should seek to enhance accessibility as is feasible. Improvements should be designed to consider people of all ages and abilities with regard to accessing the site, traveling to the transit station, and connecting to the street from the transit station. Sidewalks within the station area should have a grade of less than 5% and a cross-grade of less than 2%, wherever possible. All corners and pedestrian crossings should have fully-compliant curb cuts connecting to marked crosswalks. All new station designs shall comply with relevant accessibility standards, including the FTA's adopted Access Board's Americans with Disabilities Act Accessibility Guidelines (ADAAG).



New direct accessible walkways at East Liberty Station, Pittsburgh

Rider Comfort

A major factor affecting ridership is the rider's comfort during their whole journey. One way to improve a rider's comfort in using the system is to provide investments and amenities that make the rider experience less stressful and more convenient. Simple physical amenities --such as seating and windscreens--are low investments with high impact on ridership, and they should be provided. New technologies and aesthetic elements --such as charging stations, WiFi hotspots, landscaping, and public art--require higher investment but yield positive experiences. These additional amenities could be selectively implemented and placed at appropriate stations.

As transit evolves over time, station designers should reference and research similar LRT systems to explore best practices and new station amenities executed by similar national LRT systems.



Integrated seating, shade, and planters at Sycamore Main Station, Phoenix

Climactic & Seasonal Changes

Station design should respond to climate and weather to provide comfort to riders. Considerations for sun, wind, rain, and snow should be addressed both at the platform and the site design approaching the station.

In addition to station elements such as windscreens and canopies to protect riders from the elements, a station maintenance plan needs to be in place to address seasonal responsibilities like snow removal and autumn leaf removal.



New canopy heaters at Central Station, St. Paul

Staff Considerations

Stations also should consider the comfort of maintenance staff and train crew. Less stressful and confusing environments allow staff to focus on serving the riders and carrying out their duties. With safety being a top priority, station design should allow staff to easily survey and patrol platform areas with clear and unobstructed sight lines.

Because of their specialized knowledge, staff and crew should be involved in the design process of any station project. Special attention should be paid to their maintenance and rider safety concerns.

For stations that feature a rest-stop or layover, amenities for train operators and crew should be provided, including toilet and snack facilities.



Non-stressful work environment allows staff to concentrate on providing the best, safest service. Station Square, Pittsburgh.

VISUAL CONSISTENCY

Station maintenance, repair, and redesign efforts should strive to increase visual consistency across the PAAC LRT system. Having been built over time, the LRT system stations are highly diverse, with varying canopies, furniture, lighting, and color schemes. Although there are a few unique site-specific stations, such as First Avenue, the majority of the LRT system stations were constructed as a series of distinct families designed as the system was upgraded and expanded. Future station improvements should seek to increase the visual consistency of the outlying Red Line and Blue Line stations as a general guiding principle.

While the guidelines aim to create a level of consistency across the PAAC brand, it is also essential to recognize the diversity of the system and the importance of stations being individual. A balance is needed between network consistency and local specificity, integrating stations into the adjacent community and neighborhood.

The visual consistency principle outlines key strategies for increasing coherence and improving user experience across the LRT system as future station maintenance, improvements, reconstruction and expansion occurs.

Consistent & Appropriate Signage

Signage standards should be consistent across all stations in the system, with signage amounts and types that are appropriate for the station category. All new station and wayfinding signage should follow the *Passenger Information Design Standards Document* to create graphically consistent elements. Principles for the types, amount, and location of signage at LRT stations are outlined in the Technology and Wayfinding chapter of this document. The new family of station information display units is illustrated at right.

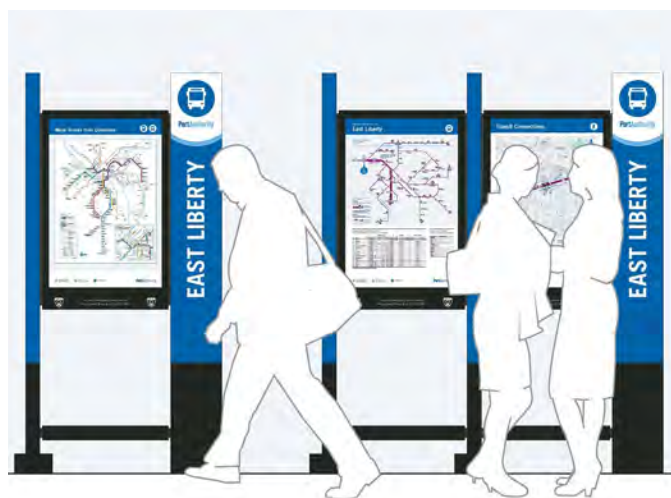

New PAAC station information display family

Uniform Color Usage

Consistency and repetition of colors, in both signage and physical elements, reinforce both legibility for riders and the PAAC brand. Future station improvements should implement new color palette guidelines to canopies, railings, fencing, furniture and lights. This document, as well as the *Passenger Information Design Standards Document*, set the standard for uniform PAAC colors. Principles for the application of the color palette at LRT stations are outlined in the Color Palette section of this document.

PAAC Blue
PMS 300 C
CMYK 100-50-0-0

PAAC Black
PMS Black C
CMYK 0-0-0-100

PAAC Light Blue
PMS 292 C
CMYK 59-11-0-0

PAAC Gray
PMS XXX C
CMYK 0-0-0-70

PAAC Light Gray
PMS XXX C
CMYK 0-0-0-30

Improved Canopies & Furniture

Future station improvements should be designed to create a more consistent platform experience for riders. New standards for station canopies and furniture outlined in this document should be applied as elements of existing stations are replaced or new stations are constructed. In limited cases, special site-specific station canopies may be deemed desirable by PAAC staff, but the general design principle is to increase visual and architectural consistency.



New canopy at East Liberty Station, Pittsburgh

New Lighting Standards

A consistent standard of lights in and around the station allows an ease of maintenance and replacement for staff. Additionally, the location of lighting helps to increase ridership by providing a standard perception of safety and visibility for the PAAC brand.

Lighting should also be used to highlight key information important to the rider's experience, such as information kiosks or ticket booths.



Site lighting at University of Washington Station, Seattle

Clutter Free Spaces

Clutter is the unwanted layer of redundant, outdated elements or non-essential items within the station --often accumulated over time --that can distract customers from efficiently navigating the station and reading key information and signs. Clutter can greatly inhibit a rider's focus and undermine the clarity of the station, and this can affect the quality of the entire journey and their perceptions of journey time. Of particular concern are elements that block circulation or sight lines. Station improvements should involve an assessment of existing elements to identify items that are either unnecessary or redundant including outdated signage, advertising, furniture, and technology and affiliated conduits. Station improvements should include the removal and consolidation of these elements. Station improvements should also strive to mitigate clutter as new station elements are introduced onto the platform and adjacent circulation paths.



Left: Conduit and electrical boxes clutter the platform at Mt. Lebanon Station. Right: Electrical and data wires are integrated into structures at North Side Station.

COHERENT SITE DESIGN

The area surrounding the station property has an equally important influence on the PAAC brand. In addition to providing the front face of the station to a passerby, the site design also connects the station to the existing surrounding public realm.

For staff and maintenance crew, a well-thought-out and efficient site design facilitates easy upkeep and care, saving time and resources. A maintenance plan for each station and its surrounding site can direct staff on what and where to maintain them, and show them which station areas require higher priority.

The rider experience should be considered well before the rider steps foot onto the station property. This consideration recognizes the importance of the entire journey of a rider, and how the PAAC brand plays a larger role in that experience. By designing past the station property boundaries, the PAAC brand can improve ridership and increase exposure.

The first consideration for the site design of a station is to focus on the users. Different stations serve different riders, with different needs and expectations. A station should respond to those requirements while understanding the needs of the wider local community.

Some common users groups include:

- Daily work-force commuters
- School children
- Tourist
- Special events spectators
- Shoppers

Legible Entrances

As the first space that a rider interfaces with, the surrounding site design should allow the station and its entrance to be easily accessed and viewed from the street, helping with locating and security.

The entrance to the station property should be welllit with signage. Stations located near local business districts or popular public spaces should also consider placing signage in these high-traffic corridors to help patrons locate the nearby station.

The entrance and pedestrian travel paths to the station should be well-connected and accessible to the surrounding area. These areas should include wide sidewalks, curb cuts, high-visibility crosswalks, and direct paths.



Entrance and identity signage at Hollywood & Vine Station, Los Angeles

Direct Walkways & Sight Lines

The primary walking path to the transit station should be as simple and direct as possible, while still maintaining accessibility for those with disabilities. To meet accessibility requirements, many stations in the PAAC's Blue and Red lines have long, circuitous, and indirect paths that lead a rider from the public sidewalk to the platform. While some stations have steep terrain and topography, a more direct and clear accessible path of travel is recommended for both ease of maintenance and perceived rider convenience.

If appropriate, stations should integrate elevators to help bridge extreme elevation changes, thus avoiding angular and indirect ramps.

Walkways widths should exceed minimum ADA standards, creating a comfortable and spacious pedestrian experience. Station furniture or amenities shall not be placed in the walking path, and should be sited with a buffer away from the walking path.



Direct platform access with integrated elevator at Leichhardt Station, Sydney

Multimodal Connectivity

Connections to other modes of transportation should be easy to find, locate, and access. This includes clear connections and signage to:

- Park and Ride parking lots
- Passenger drop-off curbs
- Connecting local bus lines
- Bicycle lanes and bicycle infrastructure

For station properties that have appropriate space, designs should integrate some multimodal options directly on the property --such as bike-share stations or adjacent bus shelters. Direct walkways, lights, and signage leading between parking lots and the stations should be provided.



Connecting bus routes at Culver City Station, Los Angeles

Site Grading & Landscape

Sidewalks within the station area should have a grade of less than 5%, wherever possible. All corners and pedestrian crossings should have fully compliant curb cuts connecting to marked crosswalks.

Additional station areas should feature pervious, landscaped areas. Landscape elements are some of the more difficult and time-consuming areas of a station property to maintain. Planting types, species, and location of plantings should be standardized so maintenance staff can execute a more efficient and effective landscape maintenance plan, with consideration for seasonal changes. Steep landscape sites should consider erosion and methods to reduce its effects. The consistency of landscape elements across the network also enhances the aesthetic appeal of the station area, adding positively to the rider experience.



Native plantings in landscaped paths at East Liberty Station, Pittsburgh

Visibility & Lighting

The level of visibility is a big indicator of how safe an area feels. Without visual access to other people and activity centers, a feeling of isolation can encourage real or perceived danger. Consequently, the visibility to and from walking connections should be maximized from all angles. By increasing visibility in both directions, to and from connections, surveillance is added to support public safety. Lighting should be significant to allow visibility of walkable areas with particular attention to pathways, stairs, entrances/exits, parking areas, and all areas where individuals may gather such as at station platforms and around ticket vending machines. Lighting should not be so bright that it creates deep shadows, glare, or discomfort for viewers. Light fixtures should not cause obstructions to visibility but should be at height to allow visibility of faces of those in the space.



Platform and site lighting at Veterans Way/College Ave. Station, Phoenix

DURABILITY & MAINTENANCE

Well-designed stations consider the life-cycle of existing and new materials and products, while design flexibility allows stations to better respond to future challenges and opportunities.

A primary benefit of carefully selecting materials based on their whole life is the reduced cost and time in the maintenance and replacement of elements by staff. As a direct effect of material durability, stations experience less service interruption, fewer platform closures, and less maintenance interference, all of which enhance the rider experience.

When examining life-cycle considerations for a material, research the sourcing of materials --through the decommissioning and all stages in-between --should be researched. More robust materials might be more desirable due to lower replacement costs and lower maintenance costs, but they will not have a desired effect without an equally robust inspection, maintenance, and replacement plan.

Material Life-span

All materials and assemblies should be of a tough, durable grade, selected for resistance to outdoor conditions and to daily public usage. Consider a material's finish, susceptibility to moisture, scratch-resistance, salt-tolerance, and exposure to the elements. Depending on the location of the material, consider the effects of graffiti and vandalism on its life-span and repair needs.

Considerations for materials should include:

- Sourcing
- Delivery
- Cost
- Manufacturing process
- Installation
- Easy access
- Parts replacement
- Performance

Protective coatings and finishes increase the life-span of a material, and they provide positive cost benefits.

Lastly, with an inspection, maintenance, and replacement plan in place, a decommissioning plan should also be developed to address the performance point of when an element has surpassed its useful life. If deemed not usable any further, then how does the decommissioned element get disposed of environmentally, responsibly, and cost worthy.

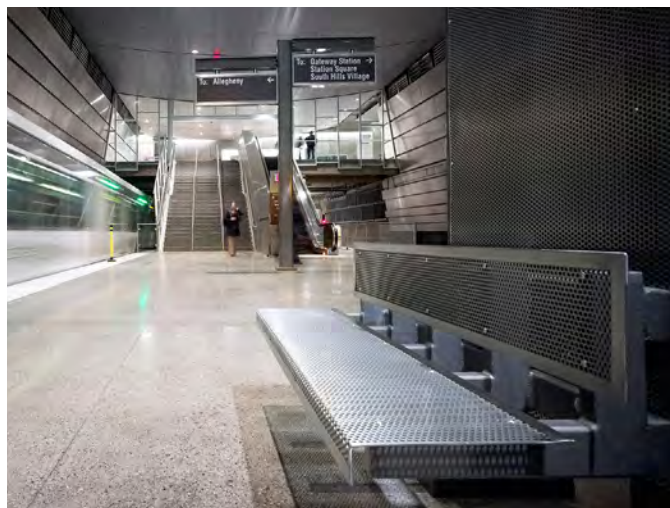

Stainless steel perforated bench at North Side Station, Pittsburgh

Modular Components

As opposed to customized systems, modular, prefabricated systems provide a reduction in cost, flexibility in design, and shorter learning time. Repetitive, interlocking elements --such as ground pavers, guard rail panels, and signage assemblies --should utilize modular systems and products. Materials for modular systems can be ordered in bulk and kept in stock, cutting down on lead times and production time.

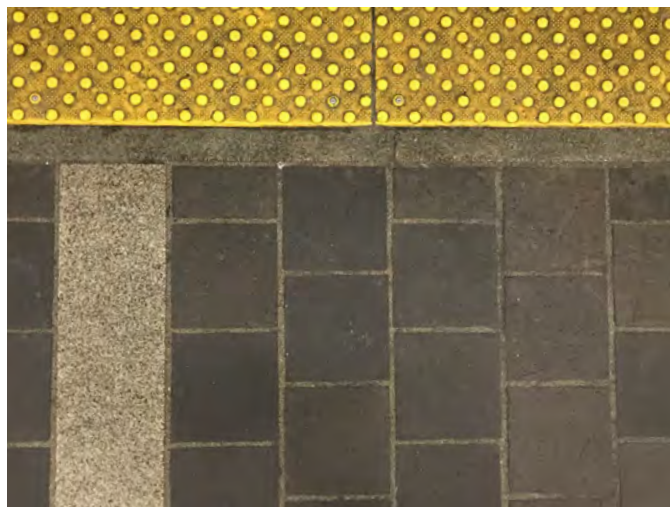

Modular floor tiles on a light rail platform

Ease of Access & Replacement Strategy

Easy, secure access to systems should be considered early in the design process to ensure that maintenance and replacement is not remote or blocked by another element.

For electrical systems, easily located access panels should be incorporated into the design of embedded internal wiring in light poles or vertical structural elements.

Replacement parts should be quick to source, easy to find, and simple to reproduce if they are produced in-house.



Standard materials and colors at East Liberty Station, Pittsburgh

Keeping It Clean

Stations should feature materials that are hard to get dirty or that look good even when dirty. Dark-textured surfaces show less dirt and markings than bright flat ones. Fabrics should not be used. When cleaning is required, surface materials should be easy to wipe down or require uncomplicated equipment and processes.

Protective coatings, such as anti-fingerprint, scratch-resistant, and anti-graffiti coatings, should be used when possible to reduce maintenance and cleaning needs.

Making spaces that are open and have less corners for snow and dirt to accumulate helps keep stations and platforms tidy. Stations should be designed with cleaning equipment in mind.



Tough materials and protective coatings at Gateway Station, Pittsburgh

Seasonal Considerations

Metals, while durable and long-lasting, are susceptible to the effects of snow, ice, and de-icing salt. Care should be taken to make sure any metal materials do not touch the ground, and are protected from winter deterioration.

In addition, extreme cold weather causes metals to expand and contract. Metals embedded into concrete --such as railings and light posts --need to be properly prepared to not cause concrete cracking and failure at the connection point.

De-icing salt and thawing processes that cause the least damage to station property and platform surfaces should be selected and applied only when necessary. Masonry surfaces, mortar joints, and surrounding vegetation should be protected from excessive de-icing exposure. In the spring, sidewalks should be washed down to disperse residue.



Snow removal at SE Washington Ave., University of Minnesota, Minneapolis

PRIMARY MATERIALS

Overview

While station elements vary widely by size and type, their composition and materiality are often the same. These primary materials should be specified and applied consistently throughout the system, both for visual and branding coherence, as well for ease of maintenance and planning. The materials should be selected based on their durability, aesthetic quality, cost, and availability.

Because these materials are the basis and foundation of the elements described in this design guideline, all PAAC staff, consultants, and contractors, should be familiar and proficient with the application and execution of these materials.

The 5 primary materials explained are:

- Concrete
- Metals
- Paint
- Color Palette
- Translucent / Transparent Materials



Fulton North Central Station, Houston

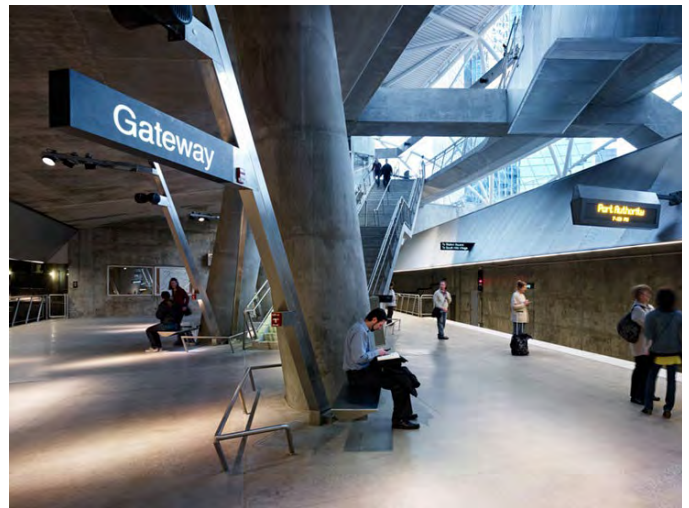

Gateway Station, Pittsburgh



Minneapolis's Metro Transit Blue Line, 50th St. - Minnehaha Station, High Platform

Primary Materials

- A Concrete
- B Metals
- C Paint
- D Color Palette
- E Translucent / Transparent Materials

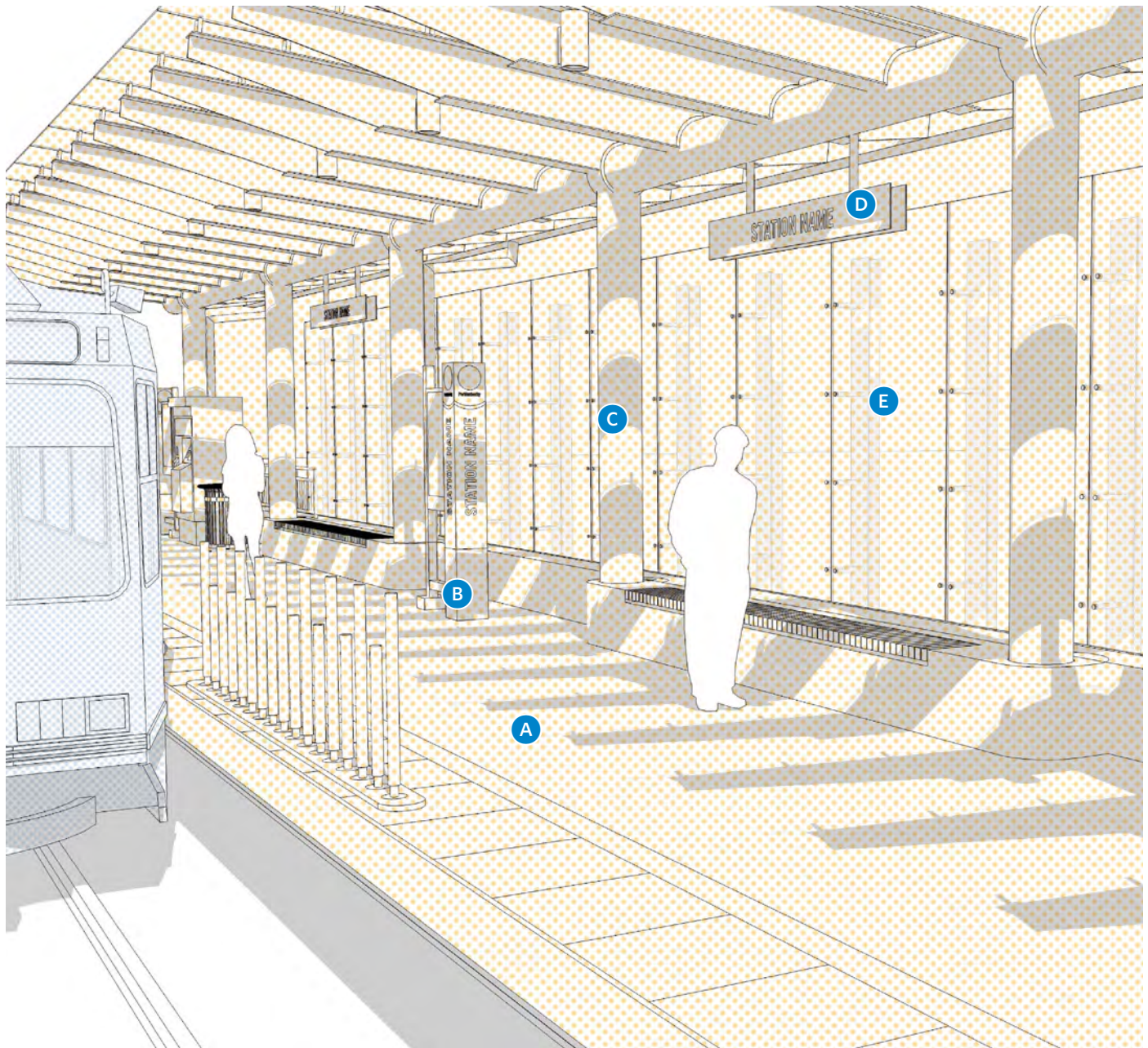

CONCRETE

General Considerations

Concrete is the primary material for station platforms, ramps, stairs, and sidewalks. Two major considerations when designing concrete surfaces and structures are the repetitive freeze-thaw cycle of southwestern Pennsylvania winters and the repetitive application of salt for safety. For snow and ice removal operations, staff utilize hand shovels and, when possible, snow blowers and snow brushes. For safety, PAAC staff salt all platforms and walkways leading up to platforms. All steps need to be hand-shoveled, and this takes considerable time where there are drastic grade changes. During the warmer months, the maintenance staff power-wash the platforms by utilizing portable water tanks and compressors. The high platforms are the focus of power-washing.

Bonding Agents

Bonding agents should be used when patching concrete because the transfer of forces between the existing concrete and patch often places the interface between existing concrete and patch in shear. Thermal cycling also causes shear stresses at bonding surfaces because surface patches heat up and cool down more easily than the concrete substrate. Bonding agents help resist the tendency of these shear stresses to separate the patch. A simple mortar scrub coat is the easiest bonding agent applied to existing concrete where patch material will be placed. Manufactured latex and epoxy bonding agents can provide higher bond strengths than a mortar scrub coat, and some can allow the patch to be placed as late as 24 hours after applying the bonding agent. Epoxy bonding agents are suitable for exterior use to bond fresh concrete or mortar to hardened concrete or bond hardened concrete to hardened concrete by crack injection or adhesion. They can also be applied to reinforcing steel as a rust-preventive coating because they will keep water and chlorides from contacting the steel.

Sealers & Overlays

Sealing concrete against water penetration can be an effective way to protect it and the steel reinforcement from weather damage. Penetrating sealers are the least-expensive materials used in this approach but they are only effective if the concrete is in good condition. Penetrating sealers fall into two categories: water repellents such as siloxanes and silanes, and waterproofing sealers such as low-viscosity epoxies and high-molecular-weight methacrylates.

Joint Sealants

Joint sealants provide continuity and weather-tightness across small gaps in construction, such as control, contraction, and material expansion joints, and at junctures between dissimilar materials. They are wet-applied using guns or pumps.

Factors that affect or relate to joint-sealant selection include the following:

- **Exterior Exposure:** For exterior applications, sealants must resist the effects of exposure to ultraviolet (UV) light, ozone, heat, water, temperature extremes, air pollution, and cleaning chemicals.
- **Traffic Applications:** If exposed to foot and vehicular traffic, sealants must resist abrasion, tearing, puncturing, and other forms of damage caused by sharp objects such as spike heels, pebbles, and debris.
- **Joint Substrates:** Joint sealants may not adhere to certain substrates or may react to certain substrates in a way that leads to eventual adhesive failure. Sealants may also react with certain substrates to produce staining or color changes, a consideration of particular importance with porous substrates, such as marble and limestone. If incompatible sealants come into contact with each other, sealant failure may result.
- **Mechanical of Joint Movement:** Joint sealants must withstand tension and compression caused by expansion and contraction of the adjacent joint walls due to thermal movement. For lap joints, additional stresses and strains are caused by one substrate sliding in relation to the other, thus inducing shearing forces in the sealant. Expansion, contraction, and sliding can occur either separately or in combination.
- **Expected Service Life:** Silicones generally have the longest expected service life, followed by urethanes and then polysulfides. Regardless of which sealants are selected, they will have to be replaced or repaired eventually.
- **Tooling Time:** Tooling time may become important if work schedules are accelerated and where joint sealants are exposed to traffic before fully curing or are subject to dirt pickup or other harmful effects caused by construction operations or local environmental conditions.
- **When specifying elastomeric performance requirements,** designers should reference ASTM C 920, Specification for Elastomeric Joint Sealants. This specification includes type, grade, class, uses related to exposure, and uses related to joint substrates.

REPAIR

The selection of products can have a significant effect on the success or failure of concrete repairs. Products must be selected to suit the specific conditions to which the repair will be subjected. Repair materials for exterior use must be highly water-resistant, freeze-thaw resistant, and able to accommodate a large temperature range.

Concrete patching and repairs begin by removing deteriorated concrete and must be done without damaging the stable concrete and reinforcing steel that are to remain. Patching and repairs should be done in a manner that will allow the repair to function structurally as part of the repaired concrete. It requires that repaired areas be simple outlines without sloping or feathering the concrete edge. Surfaces to receive repair materials must be sound and clean and should have a texture, usually called a profile, that will provide a mechanical bond between the repair and the existing concrete.

For small repair areas, patching mortars are ideal. For larger areas, cast-in-place concrete is preferred. Rapid-strengthening patching mortars, sometimes called rapid hardening or high early strength and distinct from rapid setting, can develop significant compressive strengths in a matter of hours, not days. ASTM C 928/C 928M indicates compressive strength values tested at 8 hours as well as those for 1, 7, and 28 days.

1. Polymer-modified patching mortars are especially effective for thin repairs because the latex not only improves bonding but also improves water retention during curing.
2. Silica fume-containing repair mortars are useful to increase compressive strength and decrease water permeability, but they can also increase shrinkage.
3. Concrete may be the most effective patching material for thick repairs, although placement may be difficult due to the confined spaces created by formwork and existing concrete.

REPLACEMENT

The determination of when and if concrete replacement over patching is required is somewhat of a subjective analysis. During site evaluation, careful consideration should be given to the existing concrete condition, including:

- Depth of concrete cracking and spalling is well into the slab and the structural integrity of the overall concrete is in question.
- Exposure of concrete reinforcement including welded wire fabric and steel rebar is such that the steel reinforcement is greatly compromised, requiring extensive rebar and fabric repairs.

- Percentage of surface repairs required over the entire platform exceeds more than half the exposed surface.
- Condition of pavers and warning pavers are excessive and require replacement of more than half the concrete or warning pavers.

REFERENCES

Sealers and Overlays:

American Concrete Institute

www.concrete.org

Concrete Repair Bulletin ICRI

www.icri.org/publications/bulletin.asp

International Concrete Repair Institute

www.icri.org

Portland Cement Association

www.cement.org

Joint Sealants:

Adhesives.org

www.adhesives.org

Adhesives and Sealants Council

www.ascouncil.org

Adhesives and Sealants Industry Magazine

www.adhesivesmag.com

Sealant Engineering and Associated Lines

www.sealgroup.org

Sealant Waterproofing and Restoration Institute

www.swrionline.org



Example of Corroded Concrete at an Existing Station.

METALS

General Considerations

Metals are the primary material for canopies, guard rails, and hand rails. Designers should choose the right metal for the project based on considerations that include metal type, proper and limitations. Metal types include steel, stainless steel, aluminum, and copper, all of which have a good range of properties, are easily available, and are reasonably priced. Although other alloys and metals exist (titanium, bronzes, pewter, etc.), they are typically used in specialized applications. For the normal exterior application, steel, stainless steel, and aluminum, as well as copper in specialized cases, should be the metals of first consideration.

Metals have different properties, including the following, that should be considered:

- **Ductility/Formability:** The ability to form metal into different shapes with hand tools and field equipment.
- **Weldability:** The ease of welding a material. The easier to weld materials require less preparation and less expertise with a welder. The harder to weld materials require more advanced welding techniques, and perhaps special considerations like additional gas purging, preheating, or exotic weld gases.
- **Machinability:** The ability to cut a metal with a blade. The high machinable metals can be cut at high speeds and with less expensive band saw blades, milling tools, or drill bits.
- **Tensile strength:** The amount of force you need to exert to snap a metal. When some are looking for a “stronger” metal, they usually mean they want a metal with a higher tensile strength.

Metals for consideration have certain positives (+) and limitations (-) which include:

Steel

- + Least expensive of metals
- + Versatile and moderate on all properties
- + Readily available in various structural shapes
- Susceptible to rust and needs to be protected with appropriate finish
- Harder to cut than aluminum especially in a field setting

Stainless Steel

- + Most durable and protected metal of the class — will not rust unless exposed to acid due to chromium or nickel content which forms a transparent oxide layer
- Heavy in weight
- Difficult to fabricate and maintain stainless finish, which could affect the corrosion resistance
- Warps easily when welding and loses rust protection after welding

Aluminum

- + Lightweight material
- + Oxide layer protects from rust as long as it is separated from other metals
- + Easy to machine
- + Readily available in various structural shapes
- Hard to weld
- Higher cost
- +/- Easily formable, but work hardens quickly, may need to use a torch to temper metal while hammering



Examples of corroded metals at existing stations. Top: Steel and aluminium combined in a windscreen assembly with paint failing where steel meets the platform surface. Bottom: A factory painted light post with significant corrosion from salt exposure.

Steel

Steel is an economic and practical material for use in decorative and structural applications. If steel is exposed to wear or the exterior elements, then special consideration should be given to the appropriate finish and paint system. A steel finish should be chosen based on the metals location and exposure. Painting, shop-painted, and high-performance coated are described under the paint section.

Hot-dip galvanizing provides protection for steel items against normal corrosion, especially when applied after fabrication. Unlike zinc-rich coatings, hot-dip galvanizing does not depend on a resin binder, which can deteriorate over time, and it coats and protects interior surfaces of hollow items. When designing metal fabrications for galvanizing after fabrication, conditions that require field welding should be avoided. Items should be designed in segments that can be transported easily and that will fit into the galvanizing tanks. Hollow shapes require vent and drain holes to allow the cleaning solution, air, and molten zinc to flow freely into and back out of the items. These holes can often be located so that they serve to drain the completed item of condensation and other water that might otherwise accumulate. These holes can be filled with zinc plugs that are finished to match the rest of the surfaces.

Powder coating is a process for applying a protective coating that eliminates the need for solvents, and therefore most volatile organic compounds (VOCs), and helps maintain the raw material. After cleaning, the metal object is placed in a chamber where it is given a static electric charge and sprayed with a powder coating that is given the opposite static charge. The object is then heated to fuse the resin particles usually in a thick and somewhat resilient evenly spread coating.

Stainless Steel

Stainless steel is well-suited where corrosion resistance is a major concern. The two options for stainless include Type 304 and Type 316. Type 304 is typically used for architectural applications, and can resist corrosion, but 316 is more resistant, especially to certain chemical exposure. Type 316 is about 20% more expensive than 304. Stainless steel can be finished in a mill finish, polished, brushed, or abrasive. Stainless sheets can also be colored by immersion in molten salt and acid baths producing yellows, blue, red, green, and purple transparent oxide films on the surface.

Aluminum

Aluminum is a lightweight and corrosive resistant metal that comes in many finishes. For interiors, a 0.010 mm-thick anodic coating is adequate, but for exterior applications, a minimum 0.018 mm-thick anodic coating is recommended. Fluoropolymer coatings are used for exterior decorative aluminum items and comply with the requirements for high-performance coating specified in AAMA 2604 and superior performance coating specified in AAMA 2605. Baked-enamel and powder-coat finishes comply with AAMA 2603 and are intended for applications that are not subject to high wear and used

mostly for interior use. Also, siliconized polyester coatings are available to match the appearance of fluoropolymer coating but are not as durable when used in the exterior environment.

Copper

Copper metals are unique among architectural metals because they are integrally colored with a distinctive hue as opposed to aluminum and stainless steel, which are essentially achromatic in color. The color of copper alloys varies depending on the alloy used. Coppers are often given a directional satin finish or a mirror polish and then lacquered, or they are given a conversion finish. Lacquered and conversion finishes tend to wear off when applied to surfaces that get frequent hand contact and generally will not be as attractive in those applications as a smooth uncoated finish that is maintained by periodic cleaning and polishing.

REFERENCES

- American Architectural Manufacturers Association:
 AAMA 611-1998: Voluntary Standards for Anodized Architectural Aluminum
 American Institute of Steel Construction
 AISC 360-2010: Specifications for Structural Steel Buildings
 American National Standards Institute
 ANSI A14.3-2002: American National Standard for Ladders-Fixed-Safety Requirements
 American Welding Society:
 AWS D1.1/D1.1M-2010: Structural Welding Code - Steel
 AWS D1.2/D1.2M-2008: Structural Welding Code - Aluminum
 AWS D1.6/D1.6M-2007: Structural Welding Code - Stainless Steel
 ASTM International:
 ASTM A 27/A 27M-10: Specification for Steel Castings, Carbon, for General Application
 ASTM A 36/A 36M-08: Specification for Carbon Structural Steel
 ASTM A 47/A 47M-99; Reapproved 2009p: Specification for Ferritic Malleable Iron Castings
 ASTM A 48/A 48M-03; Reapproved 2008p: Specification for Gray Iron Castings
 ASTM A 53/A 53M-10: Specification for pipe, Steel, Black and Hot-Dipped, Zinc-Coated, welded and Seamless
 ASTM A 123/A 123M-09: Specification for Zinc (Hot-Dip Galvanized) Coatings on Iron and Steel products
 ASTM A 153/A 153M-09: Specification for Zinc Coating (Hot-Dip) on Iron and Steel Hardware
 ASTM A 240/A 240M-11a: Specification for Chromium and Chromium-Nickel Stainless Steel plate, Sheet, and Strip for pressure vessels and for General Applications
 ASTM A 276-10: Specification for Stainless Steel Bars and Shapes

PAINT

General Considerations

For exterior painting, the Master Painter's Institute (MPI) standard establishes consistent terminology and unbiased product performance that should be met by any paint manufacturer that is utilized. To ensure the use of MPI-approved paints, the Contractor should include a printout of the MPI Approved Products list for each category of scheduled or specified paints.

Surface preparations are critical to coating performance. Moisture, dirt, grease, mill scale, rust, concrete dust, or other foreign materials create barriers between substrates and coating. Surfaces must be dry, clean, and in sound condition before paints are applied. The basis standards for preparing substrates are established by the Society for Protective Coating (SSPC) and the National Association of Corrosion Engineers International (NAACE).

Surface Preparation

	Iron or Steel	Galvanized	Aluminium	Pre-Finished Metals	Stainless Steel	Non-Ferrous Metals	Plastic - PVC/FRP	Concrete	Previously Painted Surfaces
SSPC-SP1 Solvent Cleaning	●	●	●	●	●	●		●	●
SSPC-SP2 Hand Tool Cleaning	●	●							
SSPC-SP3 Power Tool Cleaning	●	●						●	
SSPC-SP11 Power Tool Cleaning to Bare Metal	●								
SSPC-SP7/NAACE 4 Brush-Off Blast Cleaning	●	●	●	●	●	●		●	●
SSPC-SP14/NAACE 8 Industrial Blast Cleaning	●								
SSPC-SP6/NAACE 3 Commercial Blast Cleaning	●								
SSPC-SP10/NAACE 2 Near-White Blast Cleaning	●								
SSPC-SP5/NAACE 1 White Metal Blast Cleaning	●								
SSPC-SP12/NAACE 5 High- and Ultrahigh-Pressure Water Jetting Prior to Recoating	●			●			●	●	●
SSPC-SP13/NAACE 6 Surface Preparation of Concrete								●	

Alkyd Paint Systems

Alkyd systems are general-purpose systems for use in all applications where moderate chemical and physical-resistance properties are adequate. Avoid using alkyd coatings on concrete and masonry surfaces subject to constant dampness or saturation with water because these conditions might blister the coating systems. Latex systems are more resistant to alkalis than alkyds. Alkali-resistant primers are solvent- or water-based paints for use on alkaline surfaces, such as plaster, vertical concrete, and masonry. Surface-preparation methods can include hand- and power-tool cleaning and pressure washing. Finish coatings applied over these primers include conventional latex and alkyd paints.

Latex Paint Systems

Latex systems have replaced alkyd systems as general-purpose systems in many locations due to their lower VOCs. Latex paints are not as abrasion resistant as alkyd paints, but they are more flexible. Latex primers do not penetrate as well as alkyd primers, and will allow water-soluble stains to bleed through from the substrate. Water-based light industrial coatings have better physical and chemical resistance than typical latex paints. They have better UV resistance than alkyds and are a good choice for replacing alkyds where VOC content limits require a water-based paint.

Enamel Paint Systems

Quick-drying enamel systems have resistance to corrosion, chemicals, and solvents comparable to conventional alkyd systems. They are often used on structural and ornamental steel in commercial and light-industrial locations, because of their fast-drying properties. Quick-drying alkyds generally are made from medium to short oil-modified alkyd resins. In some cases, the modifier can be a styrene or vinyl toluene polymer. Quick-drying alkyds are most often applied using spray equipment, but brushes and rollers can be used in small areas. Where used on steel, quick-drying primers require a higher level of surface preparation than slower-drying primers, because they do not "wet-out" the steel surface as well. For steel, primers are often specified to be applied in the fabricating shop and then touched up and finish coated on site.

Aluminum Paint Systems

Aluminum paint systems use aluminum paint as the topcoat and intermediate coat if any. Aluminum paint is an aliphatic solvent-based coating made from a varnish or an alkyd binder combined with aluminum pigment. Aluminum paint systems are used on interior and exterior wood, metal, and bituminous-coated surfaces, and occasionally on prepared masonry surfaces as a stain-blocking coating and sealer. They should be specified for use only in areas subject to low contact and abrasion.

REFERENCES

Master Painters Institute:

MPI Approved products lists. (www.paintinfo.com)

MPI Architectural Painting Specification Manual. 2012.

The Society for Protective Coatings:

SSPC-PA 1-2000 (Revised 2004): paint Application Specification No. 1: Shop, Field, and maintenance painting of Steel

SSPC-SP 2-1982 (Revised 2004): Surface preparation Specification No. 2: Hand Tool Cleaning

SSPC-SP 3-1982 (Revised 2004): Surface preparation Specification No. 3: power Tool Cleaning

COLOR PALETTE

Existing Color Palette

The LRT system has 52 different station stops. This particular guideline applies to the 47 distinct stations south of and including the First Avenue station. Many of the 47 stations vary in design, size, configuration, and aesthetic. A consistent, cohesive brand/color palette for the LRT has not been established. This presents challenges in terms of maintenance, operations, messaging, etc. Maintenance staff have a multitude of colors they must stock and manage. Signage and marketing staff cannot create a unified color scheme that can work at every location.

Approach

Color selection has a strong influence on paint performance. The amount of ultraviolet (UV) light absorbed or reflected by the color affects how long a paint job will last.

While dark colors can provide a pleasant contrast and draw attention to architectural detail, they are much more prone to fading. Dark colors also pose more maintenance problems. Dark colors absorb heat and suffer more moisture problems than lighter shades. That's why lighter colors last longer and fade less than dark colors.

Neutral colors often serve as the backdrop in design. They are commonly combined with brighter accent colors. However they can also be used on their own in designs, and can create very sophisticated layouts.

Inorganic colors (beiges, browns, tans, and other earth-tone colors) are more stable on exterior exposure. The pigments used in these colors are less likely to break down than the pigments in organic colors such as reds, blues, greens, and yellows.

To refresh and standardize the Port Authority signage throughout the system, PAAC has developed new signage standards. Within the signage standards, six colors have been selected for use in various locations. The primary signage colors are two hues of blue and a black. The secondary colors are for use in differentiating the various busway lines. The signage color standards should be built upon by integrating and enhancing the colors selected for use at LRT station. The PAAC approved colors should be complemented with either more of the same colors or hues or neutrals and possible accent colors that enrich the rider experience.

NEW

In an effort to provide a consistent and cohesive color palette, PAAC has adopted a color palette that addresses the subjects listed above.

Metals:

- New Stainless Steel - Do not paint
- Existing Horizontal Elements:
Guards and Rails - Gray
- Vertical Elements:
Canopy Steel - Gray
Light Poles - Gray

Other Elements / Materials:

- Canopy Cover - Light Gray
- Furniture - Black
- Signage:
Background - Blue
Text - White
Accent - Light Blue

PAAC Blue PMS 300 C CMYK 100-50-0-0	
PAAC Black PMS Black C CMYK 0-0-0-100	PAAC Gray PMS XXX C CMYK 0-0-0-70
PAAC Light Blue PMS 292 C CMYK 59-11-0-0	PAAC Light Gray PMS XXX C CMYK 0-0-0-30

TRANSLUCENT / TRANSPARENT MATERIALS

General Considerations

Translucent materials are often used throughout transportation projects. They are utilized in several applications: windscreens, canopy roofs, signage, etc. The two most prevalent translucent materials are plastic glazing and float glazing. Multiple kinds of plastic glazing and float glazing exist and each has pros and cons that should be considered when using the materials within station design.

MATERIAL CHARACTERISTICS

Glass

Glass used in architectural applications is generally called flat glass. This term includes float glass, plate glass, sheet glass, and various forms of rolled glass. The term monolithic glass is used to refer to glass that consists of a single ply or lite, to distinguish it from laminated or insulating glass. Minimum and maximum glass sizes may depend not only on the thickness of the glass but also on limitations imposed by fabrication, handling, and installation. The industry recommends a maximum length-to-width ratio of 6:1.

Laminated Glass

Laminated glass consists of two or more plies of glass bonded together with an interlayer material. A choice of laminated-glass products is available to suit many glazing applications, such as safety glazing and overhead glazing. Three different materials can be utilized in the laminating process: polyvinyl butyral and ionomeric polymer sheet, which are bonded to glass lites under heat and pressure in an autoclave, and cured resins, which are pumped or poured into a space of specified thickness between two lites and then cured under UV light or heat.

- Polyvinyl butyral is the most widely used interlayer and is available in clear, color-pigmented, and pattern-imprinted sheets. The sheets can also be combined in multiple layers to achieve different effects.
- Ionomeric polymer interlayer material, also called Ionoplast, was developed to provide a tougher material for windborne-debris-impact resistance. It is far stiffer than polyvinyl butyral and provides better structural coupling between the glass plies than polyvinyl butyral does. Ionomeric polymer interlayer material is also less vulnerable to moisture exposure, which makes it the preferred interlayer for structural-sealant-glazed applications and applications where the edge of the glass will be exposed to the weather.
- Cured resins are less expensive for manufacturers than polyvinyl butyral sheet because there is no outlay of capital for an autoclave. Polyethylene terephthalate film can be used between cured resin layers to reinforce the laminated glass if needed for windborne-debris-impact resistance.

Safety Glazing

Safety glazing is required for locations subject to human impact. The International Building Code (IBC) and the International

Residential Code (IRC) have jurisdiction over glazing installed in buildings, but the majority of the glazing within the light rail system is not associated with a building.

Safety glazing typically requires fully tempered glass or laminated glass. For laminated glass used as safety glazing, a 0.015-inch or 0.030-inch (0.38- and 0.76-mm) interlayer thickness is usually required. Other Thickness can be required depending on the category mandated by code.

- CATEGORY I: Impact safety level designated by “code of federal regulations” part 16. (16 CFR). “Category I” glazing materials are subjected to impact of 100 lb. bag swung from 18” drop height (approx. 150 ft/lb impact), with no single piece of glazing material greater than 9 square feet in surface area. Cat I resembles an 85 lb. child running into the glazing material.
- CATEGORY II: Impact safety level designated by “code of federal regulations” part 16. (16 CFR). “Category II” glazing materials are subjected to impact of 100 lb. bag swung from 48” drop height (approx. 400 ft/lb impact), with any piece of glazing material greater than 9 square feet in surface area. Cat II resembles a full-grown adult running into the glazing material.

Plastic Glazing

The main plastic glazings are acrylic and polycarbonate. Acrylic sheets are composed of polymerized acrylic monomers; at least 80% of these are methyl methacrylate. Monolithic forms for glazing include transparent colorless, transparent tinted, translucent white, and semi-opaque color sheets.

Acrylic

The optical quality and light transmittance of cell-cast, clear acrylic sheets are comparable to clear float glass. Acrylic plastic sheets are more resistant to impact than annealed glass but are less rigid and abrasion resistant. Acrylic plastic sheets are 23 times less rigid than glass.

Polycarbonate

Polycarbonate sheets are composed of unfilled polyester plastics. Monolithic forms for glazing include transparent colorless and transparent tinted with and without coatings and other treatments to make them more resistant to abrasion and yellowing. Polycarbonate sheets are more impact resistant than acrylic sheets but are less rigid. The light transmittance of clear polycarbonate is 88%, making it less transparent than ultraclear glass. For weight and water-vapor transmission, their properties are similar to acrylic sheets. Both acrylic plastic and polycarbonate plastic sheets weigh about half that of glass of the same thickness. Plastic glazing products are combustible, so precaution should be exercised in their use.

REPAIR

Due to the nature of glazing materials there are limited methods to repair damaged or defaced materials; most must be replaced. However, if designed properly the amount of replacement can be minimized. For example, the glazing that is within the reach of patrons is more likely subjected to damage (scratching, breaking, and/or graffiti). It is recommended that laminated glazing be utilized in those locations. Although it can be cracked with a great deal of force, it can be easily cleaned of graffiti and is more resistant to scratching as these are more likely to occur than breaking.

REPLACEMENT

It is recommended that damaged and/or defaced glazing units be replaced in kind as needed. If it is determined that the amount of damaged glazing material is significant enough to warrant full replacement of an entire element (ie. windscreen), it is suggested that the designer consider an alternate glazing system for use within the new element.

NEW

It is recommended that solid polycarbonate translucent panels be utilized for new canopy roofs. This will provide the maximum daylighting while providing protection from direct sunlight and other weather elements. At locations where the riders can touch, such as windscreens and other advertising locations, it is recommended to utilize clear laminated glazing. This will provide protection from the elements while allowing visibility for passenger safety, durability, and lower maintenance for PAAC staff.

REFERENCES

Model Building Codes

International Code Council. International Green Construction Code. Washington, DC: ICC, 2012.

Association Publications

American National Standards Institute. ANSI Z97.1: Safety Glazing Materials Used in Buildings - Safety Performance Specifications and Methods of Test. Washington, DC: ANSI, 2004.

ASTM International. ASTM C 1651: Test Method for Measurement of Roll Wave Optical Distortion in Heat-Treated Flat Glass. West Conshohocken, PA: ASTM, 2011.

_____. ASTM C 1652/C 1652M: Test Method for Measuring Optical Distortion in Flat Glass Products Using Digital Photography of Grids. 2006.

Glass Association of North America. GANA Sealant Manual. Topeka, KS: GANA, 2008. (Available at www.glasswebsite.com)

_____. GANA Guide to Architectural Glass. 2010. (Available at www.glasswebsite.com)

Safety Glazing Certification Council. SGCC Certified Products Directory - Safety Glazing Material Used in Buildings. Sackets Harbor, NY: SGCC, (Updated semiannually). (P.O. Box 730, Sackets Harbor, NY 13685; 315-646-2234)

Websites

Glass Association of North America: www.glasswebsite.com

Glazing Industry Code Committee: www.glazingcodes.org

Insulating Glass Certification Council: www.igcc.org

Insulating Glass Manufacturers Alliance: www.igmaonline.org

Lawrence Berkeley National Laboratory; Environmental Energy Technologies Division; Building

Technologies Department; Windows & Daylighting Group: <http://windows.lbl.gov>

National Fenestration Rating Council: www.nfrc.org

National Glass Association: www.glass.org

Safety Glazing Certification Council: www.sgcc.org

Standards Design Group, Inc.: www.standardsdesign.com

COMMON ELEMENTS

Overview

Common elements are essential to every station regardless of station category or site context. While the size of platforms and canopies varies from category to category, the majority of the common elements are constant for all stations.

Common Elements

- Platforms
- Platform Canopies
- Walkways, Ramps, and Stairs
- Guardrails, Handrails, and Gates
- At-Grade Track Crossing
- Between Car Barriers
- Salt Storage



Common elements at North Side Station, Pittsburgh



Common elements at Expo Park Station, Los Angeles



Common elements at Tukwila International Boulevard Station, Seattle

Common Elements

- A** Platforms
- B** Platform Canopies
- C** Walkways
- D** Ramps
- E** Pedestrian Guardrails
- F** Handrails
- G** Stairs
- H** At-Grade Track Crossing
- I** Between Car Barriers

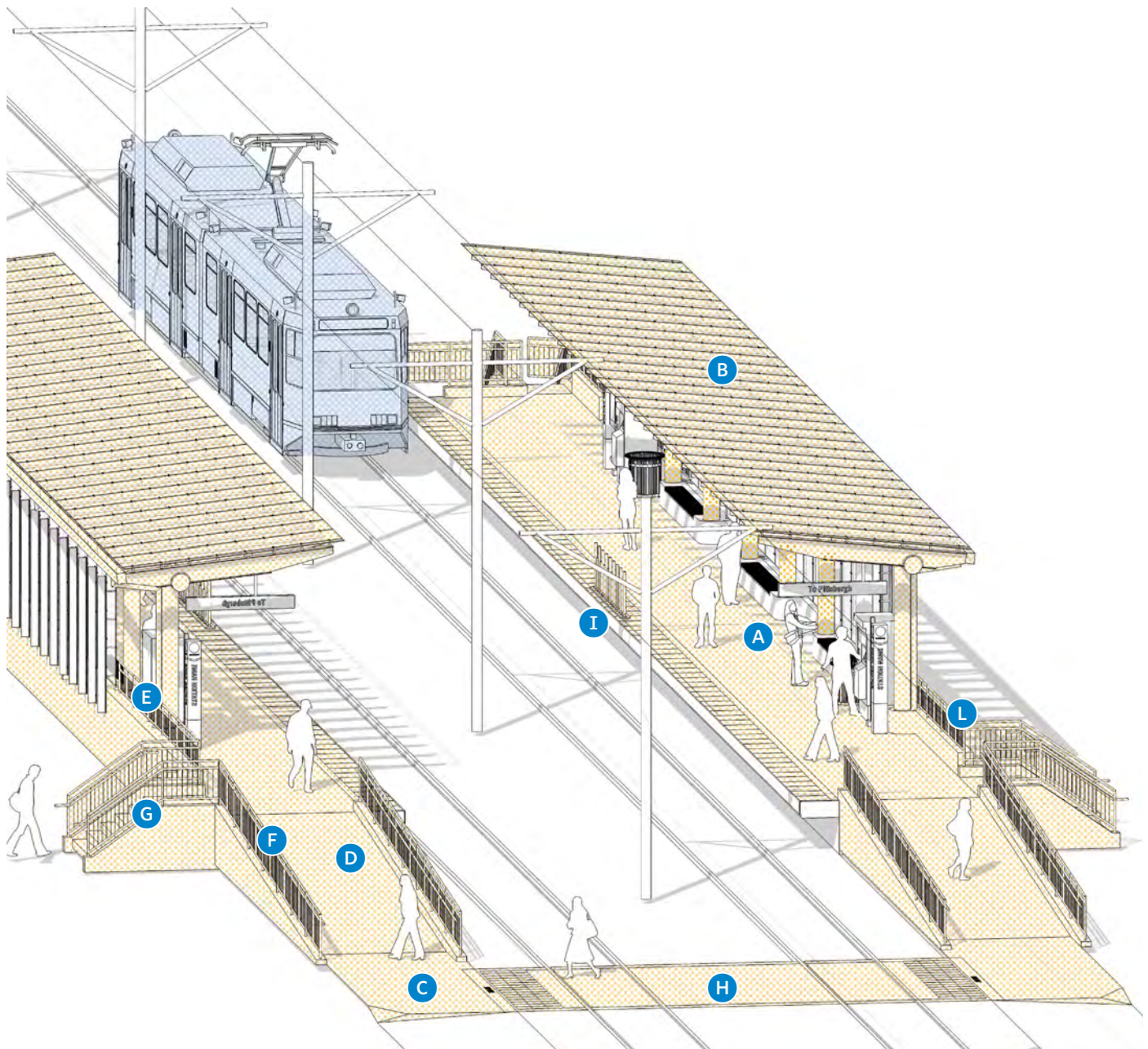

PLATFORMS

The platform is the ingress and egress point to the light rail vehicle. Light rail vehicles, platforms, streets, and walkways all work together as a system to provide accessible boarding in an efficient manner. The platform placement and ease of direct access, along with the platform length and height, are all important factors to consider when developing a station that will improve transit speed times and enhance the appearance of the station.

EXISTING

Types

Different types of existing platforms include elevated and at grade, as well as long and short platform lengths. Most of the stations are separated into distinct inbound and outbound side positioned platforms, but there are several stations that are center positioned, which allows both inbound and outbound passengers to alight from a single platform.

Material

The materials for the various platforms include concrete, asphalt, and concrete pavers. Most of the platform edges have either an integrated warning strip of scored concrete or a flush/surface-mounted tactile warning paver.

Challenges

Maintenance of the platforms is driven by winter operations and providing safe patron conditions. The use of salt during snow and ice events results in contributing to the winter freeze-thaw and temperature change, all of which affect the platform surface. When existing platform surfaces are in poor condition with cracks, spalling, uneven surfaces, and sagging platform edge conditions it affects both accessibility and safety for the passengers.

Opportunities

Replacing platforms or portions of platforms can improve safety, accessibility, and a platform's aesthetic appearance.



Existing elevated, long Dormont Junction platform and canopy

REPAIR

Repairing the platform surface should be considered when the surface level change is greater than a half-inch and the overall surface condition is less than 50% damaged. The repair material should match the adjacent surface and provide a level conditions with no elevation changes greater than a half-inch unless ramping is provided. The surface should be stable, firm, and slip-resistant and comply with accessibility standards.

When the platform edge is uneven and the gap is greater than 3 inches, it should be adjusted. The platform gap is the space between the light rail vehicle and the edge of the station platform often created by geometric constraints. The ideal platform would be straight and align perfectly with the light rail vehicle. A small gap between the vehicle and the platform is necessary to allow the train to move freely without rubbing against the platform edge. Accessibility requirements mandate a critical distance for the gap be no greater than 3 inches between the vehicle and the platform edge and the height of the vehicle floor shall be within 5/8-inch of the platform surface.

REPLACE

Replacing of the platform completely, or just the top surface, should be considered where there is significant heaving or settling, or where the platform surface is compromised by more than 50%. If it is determined that the entire platform needs to be replaced due to structural issues or a major reconstruction, then an evaluation of the platform size and configuration should be considered to align with accessibility needs and passenger volume.

In many cases, the existing platform edge has settled or is beyond repair and needs to be replaced in its entirety and with a solid concrete edge. The high platforms have been designed to provide adjustability to the platform edge to meet ADA requirements. The current design includes concrete pavers set into a sand bed with a continuous stainless-steel plate along the outermost edge. There is a minimum half-inch gap between the stainless-steel plate and the pavers that is filled with a bead of sealant. As the gap changes, the pavers can be modified to correct the gap, but the design allows for water to penetrate and erode the sand bed causing settlement. To avoid the regular maintenance issues related to warning paver settlement, it is suggested that platform edges be replaced to remove the recessed pavers and sand bed. The new design would require rebuilding the cantilevered edge to make it a solid concrete slab level with the platform. Fiberglass warning pavers should be surface mounted to the concrete. Any future adjustments should be handled by realignment of the track beds.

NEW

Placement & Orientation

Platform placement and orientation depends upon the available site constraints and limits available for the station and LRT track alignment requirements. However, careful consideration should occur when developing passenger circulation and access lines to the platform in relation to the surrounding walkways and streets.

Size & Configuration

When planning a new platform, the sizing and dimensions established are modeled after existing system platforms and must also meet any life safety standards and ADA accessibility requirements for clearances. Stations with high numbers of riders congregating at one time require a wider platform. These stations typically should have a minimum platform width of 9'-0". The smaller stations have lower ridership counts and therefore can have smaller widths. These stations typically should have a minimum width of 8'-0". Greater depths are desirable when feasible. The platform length should accommodate a 2-car train length (current 2-car train model length is 180'+clearances). For Category 4 and Category 5 stations, this length might not be feasible due to site restrictions.

Construction

All boarding platforms within the system, although varying in shape and size, shall be constructed of concrete. The high platforms should be constructed with an elevated slab that is supported by cast in place concrete retaining walls. The elevated slab should be aligned with the rear retaining wall, but extends cantilevered over the front wall. The cantilevered slab edge should extend approximately 24 inches beyond the face of the wall and have either surface applied detectable fiberglass warning pavers or recessed detectable concrete warning pavers.

Accessibility

The station design shall comply with relevant accessibility standards, including the FTA's adopted Access Board's Americans with Disabilities Act Accessibility Guidelines (ADAAG). All accessible entrances shall, to the maximum extent practicable, coincide with those used by most of the public. Where the circulation path is different, signage complying with ADAAG shall be provided to indicate direction to and identify the accessible entrance and accessible route. Platform barriers complying with ADAAG requirements shall be provided.

Material

The preferred platform material is concrete. Concrete guide specifications are shown in the structural specification drawing.

Warning Pavers

All platform edges require the integration of a visually contrasting tactile warning strip of 24 inches wide to ensure rider safety. Platform edge strips shall conform to ADAAG Section 705, Detectable Warnings and 406, Curb Cuts. Fiberglass detectable warning pavers are preferred because they are less expensive, require less maintenance, and are easier to replace if damaged. The warning pavers shall have a contrasting color from the concrete platform to provide a visual contrast per ADA guidelines. If necessary, a 6 inch wide dark band can be added adjacent to the pavers to provide the visual contrast. The dark band should be constructed of a durable low maintenance material, such as integrally colored concrete or pavers.

Platform Dimensions

Station Category	Platform Width	Platform Length
	Minimum	Minimum
Category 1	9'	180'
Category 2	9'	180'
Category 3	8'	180'
Category 4	8'	180'*
Category 5	8'	180'*

* Extend existing platform length if feasible.

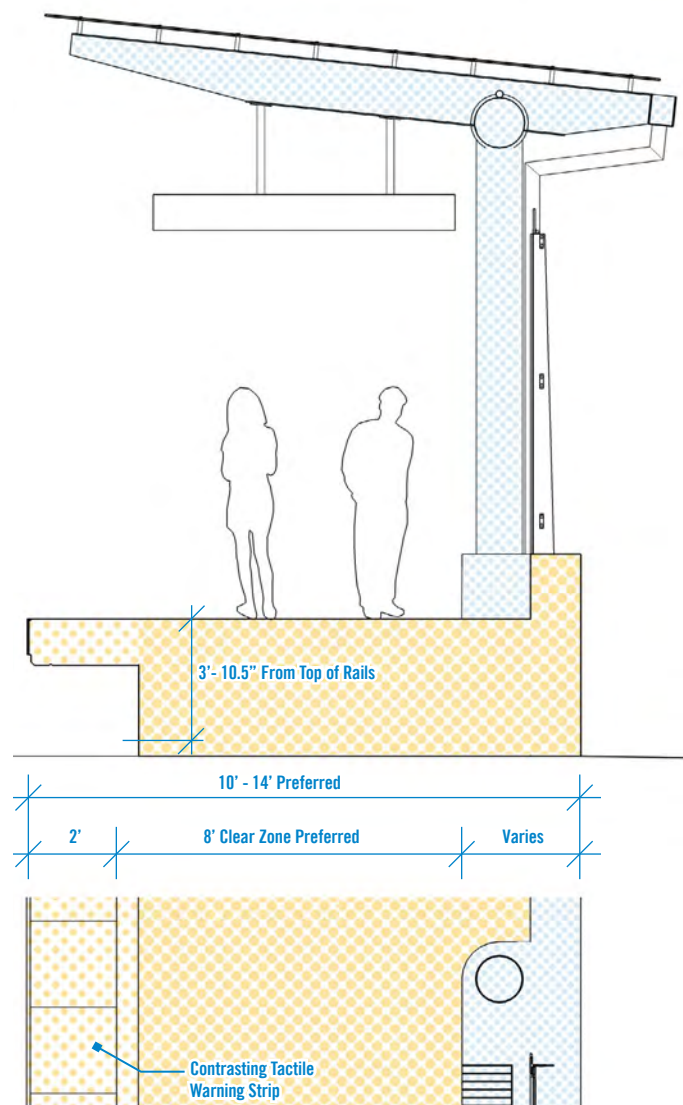

New Platform Typical Section and Plan Detail

PLATFORM CANOPIES

Canopies are typically placed over seating or designated waiting areas at stations. Canopies can serve multiple functions at a station: they can help define a station's aesthetic and character, and they can help provide protection from the weather and improve overall comfort for the passengers providing cover from rain, snow, and sun.

EXISTING

Types

There are different types of existing platform canopies shelters within the overall system. The sizes and shapes vary greatly between stations with many of the stage I shelters being simple shed roof structures with painted tube steel frames and stage II canopies that are arched with an eyebrow glass storefront front edge to help add weather protection and are supported by cast-in-place exposed aggregate columns. There is some consistency within the stage II canopies and few of the stage I stations but many stations are not consistent with canopy structures ranging from single slope shed roofs, arched frames, gable roofs and even flat roofs.

Materials

The materials for the various platforms canopies include steel for columns and roof framing, and aluminum for the roof structures and fascia. Concrete columns are utilized at some of the flat canopies and concrete pilasters at the stage I & stage II stations and have varying surface and color treatments.

Challenges

Over time, canopies need to be maintained and can go through significant additions of conduit to support lighting and data requirements. Periodically, old, unused, or abandoned conduit should be removed so re-painting of steel supports can occur.

Opportunities

Canopies needing major repairs or replacement provide an opportunity to introduce translucent roof panels that can provide a more open and airy environment for the platform users.

REPAIR

The existing canopies are mostly steel framed with painted columns and roof framing that require periodic re-painting (see the Paint write-up in the Common Materials section for surface preparation and suggested paint types). For consistency, see the Color write-up in the Common Materials section which provides an overview of the various colors that a canopy should be painted. If there are horizontal roof framing members of a canopy, "Bird Spikes" should be considered at those members to help reduce nesting and bird droppings on the platforms.

REPLACE

Replacement of a portion of a canopy or element of a canopy should only be considered if there is no plan to provide an entirely new canopy at that station or if the portion of replacement cannot

be made with a simple repair. Replacing a canopy in-kind would be highly unlikely and not recommended.

NEW

Placement & Orientation

The canopy placement should be positioned to most effectively protect the passenger from weather with respect to the platform edge and LRT boarding, by avoiding a large gap between the canopy edge and the LRT vehicle. The long edge of the canopy should parallel the platform edge and maximize the canopy protection for as much of the LRT vehicle openings as possible. For platforms with shorter canopies, they shall be biased towards the front of the platform, or the location where a 1-car train stop for boarding and alighting.

Size & Configuration

Canopies should be designed to accommodate the number of passenger using the station plus sized to reflect the service needed and future increased demand. Canopies should be designed so waiting passengers can easily see oncoming vehicles with no obstructions on the ends of the canopies. The canopy framework or roof support structure should avoid lending itself to climbing or hanging and shall be located above 9'-0". Ideally, the canopy length shall cover the length of a 2-car train, which shall be the case for Category 1 and Category 2 stations. For Category 3 stations, if the canopy length cannot accommodate a 2-car train, then it shall at a minimum accommodate a 1-car train, and be biased towards the front of the platform, or the location where the train stops for boarding and alighting. Category 4 and Category 5 stations shall provide a canopy which feasibly fits its platform conditions. The canopy roof shall slope away from the vehicle when possible, or provide a gutter to avoid drip lines on the platform edge. The canopy front edge shall be no closer than 18 inches from the vehicle when parked at the platform edge. Canopies with very high roofs and no side walls provide little protection from the wind or rain and should be avoided.

Materials

New canopy materials should maintain the overall existing system materials and be consistent. Canopies should utilize either steel or concrete columns, and at a minimum, a concrete base to avoid contact with rock salt during the winter months. Canopy roofs should be steel-framed with a protective coating and consider translucent roof panels that provide diffused light making the platform space feel open and airy while still providing rain and sun protection. Stainless steel or aluminum should be utilized for trim, fascia, gutters, and downspouts.

Conduit Management

Conduit is required to provide power and data needs to the canopy lights, speakers, and display boards. Conduit should be minimized as much as possible and always be placed at the top edge or back side of structural members to avoid sight lines from the predominant viewing angle, front, or platform edge.



Station canopy at East Liberty Station, Pittsburgh

Canopy Dimensions

Station Category	Canopy Length
	Minimum
Category 1	2-Car Train
Category 2	2-Car Train
Category 3	1-Car Train*
Category 4	1-Car Train*
Category 5	1-Car Train*

* Extend to cover platform length if feasible.

Preferred Canopy Design

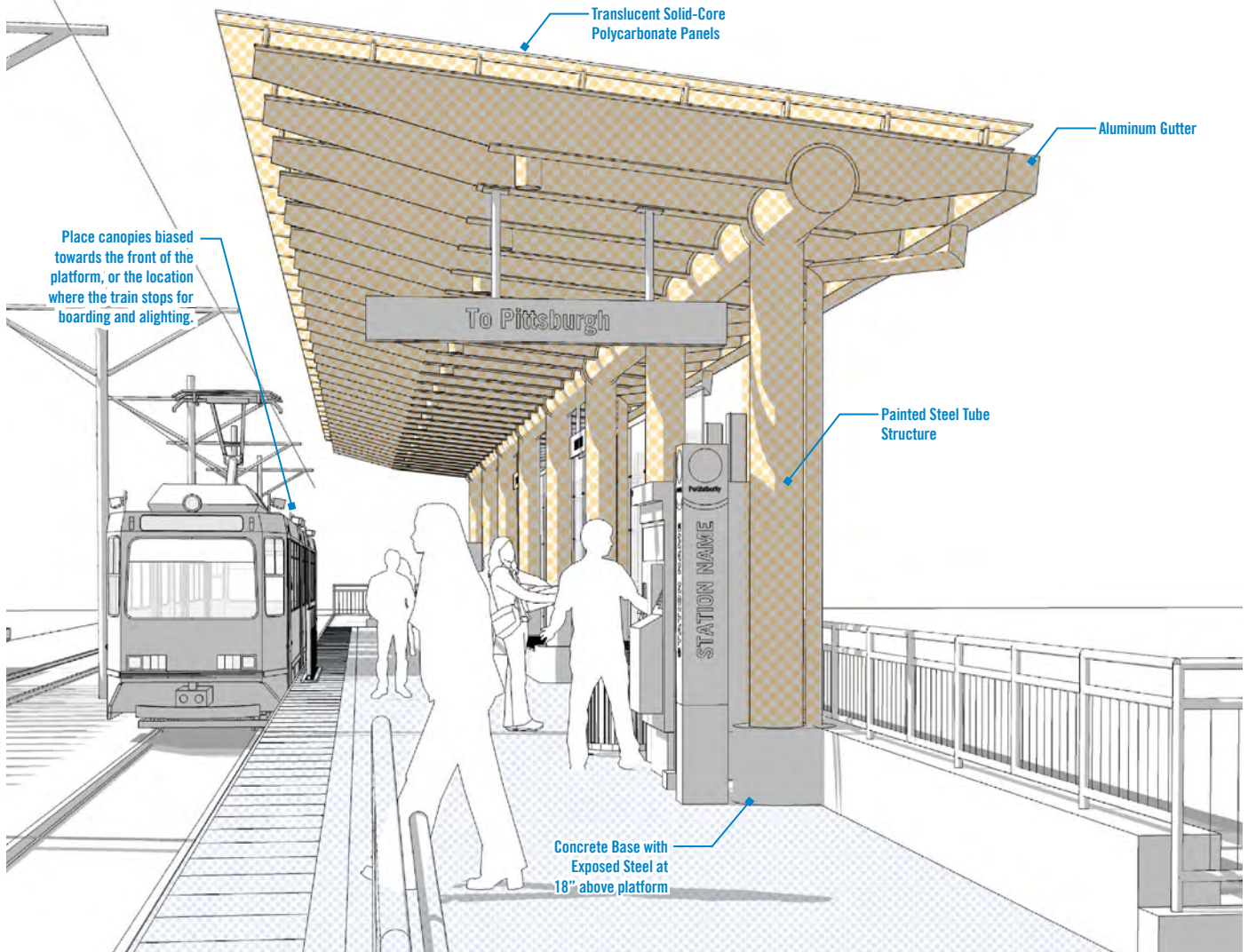

WALKWAYS, RAMPS, & STAIRS

The walkways, ramps, and stairs serve to support access to and from the platform and the LRT vehicle boarding area but also help to transition the passengers from the busy streets and sidewalks into the station entrance and LRT environment. This transition should be simple, clear, and accessible and can provide an opportunity for ease of movement of pedestrians and cyclists while promoting the station space.

EXISTING

Types

The existing walkways, ramps and stairs are in various states of disrepair and made of varying materials. They were installed during different periods, largely with the intent of providing the most basic access to the platform.

Material

The materials for the various walkways, ramps, and stairs are primarily of either concrete or asphalt.

Challenges

Due to the heavy use of salt during the snowy winter months the walkways, ramps, and stairs are in many cases are heavily corroded and need to be replaced.

Opportunities

Replacing walkways, ramps, and stairs provides an opportunity to reconfigure and improve access and accessibility to the station and platforms.

REPAIR

Repairing the walkways, ramps, and stairs depends on the type of material and condition of the surface. Much like the platforms, if a concrete or asphalt surface is heaving, spalling, or has large cracks for 50% or less of the surface, then repairing the surface may be appropriate.

REPLACE

Replacing of the walkways, ramps, and stairs is recommended when 50% or more of the area or surface is in poor conditions or is not level and safe. Similar to platforms, walkways, ramps, and stairs must be safe and meet accessibility standards, while not having cracks or vertical difference of more than a half-inch.

NEW

Placement & Orientation

Walkways shall be provided to help connect the station platform with other elements surrounding it, such as ramps, access and egress points, drop-off and pick-up areas, parking, bus stops, and local municipal, county, or PennDOT sidewalks and walkways. Walkways should connect these elements as directly as

possible, avoiding circuitous and lengthy routes or switchbacks which could lead to passenger confusion. Isolated and remote or hidden pedestrian walkways should be avoided. Where avoidance is not feasible, walkways should be as open as possible and well-lit. Walkways should have a continuous common surface, not interrupted by steps or abrupt changes in elevation. Wherever walkways cross other walkways, driveways, or parking lots, they should blend to a common level.

Ramps are a quick and safe way to gain access to a raised platform, or navigate grade changes, and are preferred over stairs, which are more difficult to maintain in snow and ice. Each raised platform shall have at least one access ramp that meets accessibility requirements, and provides a clear means of egress from the

Walkway Dimensions

Lower Density Streets	5-foot Min. Width
All Other Density Areas	6-foot Min. Width
Leading to a Platform Ramp	6-foot Min. Width
Separating Platform From Parking	6-foot Min. Width
Maximum Slope of a Walkway	1:20 or 5%
Maximum Cross Slope of a Walkway	1:48 or 2%

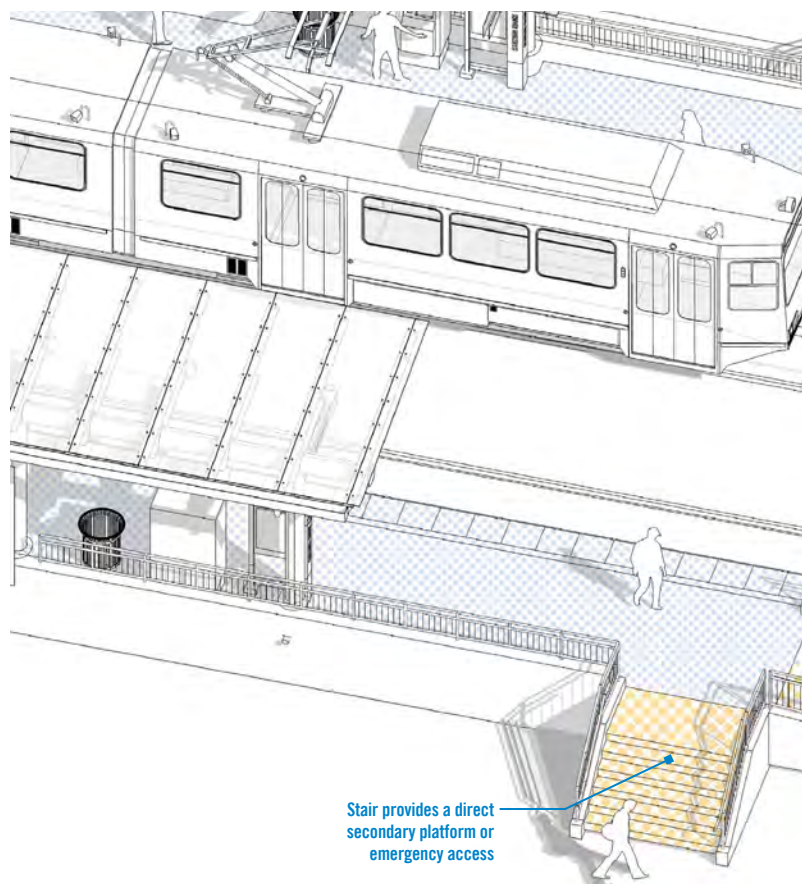

ramp to a safe distance from the vehicle and platform which may be the station point of entry or crosswalk. Ramps should be built to be smooth and without vertical rise and a maximum slope of 1:12 from sidewalk to platforms or other site elements. Ramps are preferred to be 1:20 or less so to avoid the need for handrails.

Ramps leading onto a platform shall be flanked on each side with a concrete curb to raise the guard and handrail off the ramp surface to help minimize wintertime salt exposure on the metal rails. Critical dimensions that may apply to ramps are below.

Stairs shall be positioned at the end of the platform, or in the middle of a platform. The platform stairs should avoid a change in direction and be straight stairs running in the most direct line

of travel and egress for safe exiting. Stairs shall meet all applicable building codes and ADA accessible guidelines for width, rise, tread width, and handrail requirements. Stairs leading onto a platform shall be avoided unless there is insufficient area to accommodate a ramp. The stair width shall be determined by the number of occupants egressing the platform, and stair design should follow the requirements below.

Materials

The preferred material for new walkways, ramps, and stairs shall be concrete. Refer to the “Primary Materials: Concrete” in Section 3.2 of these LRT Station Design Guidelines for additional information.

Ramp Dimensions

Slope of Ramp	Not to exceed 1 foot in 12 feet Max.
Slope of Ramp	Preferred 1 foot in 20 feet
Landings	Slope <5% every 2’-6” Rise in Elevation
Surface	Slip-resistant per ADAAG
Width Minimum	5 feet
Width Preferred	6 feet

Stair Dimensions

Standard Width for Public Use	5 feet Minimum
Public Use Preferred Width	6 feet Minimum
Service Stair Width	3 feet 8 inches
Treads and Risers	Per Building Code
Treads and Nosing	Slip-Resistant Surface
Treads Nosing	Strip of Clearly Contrasting Color

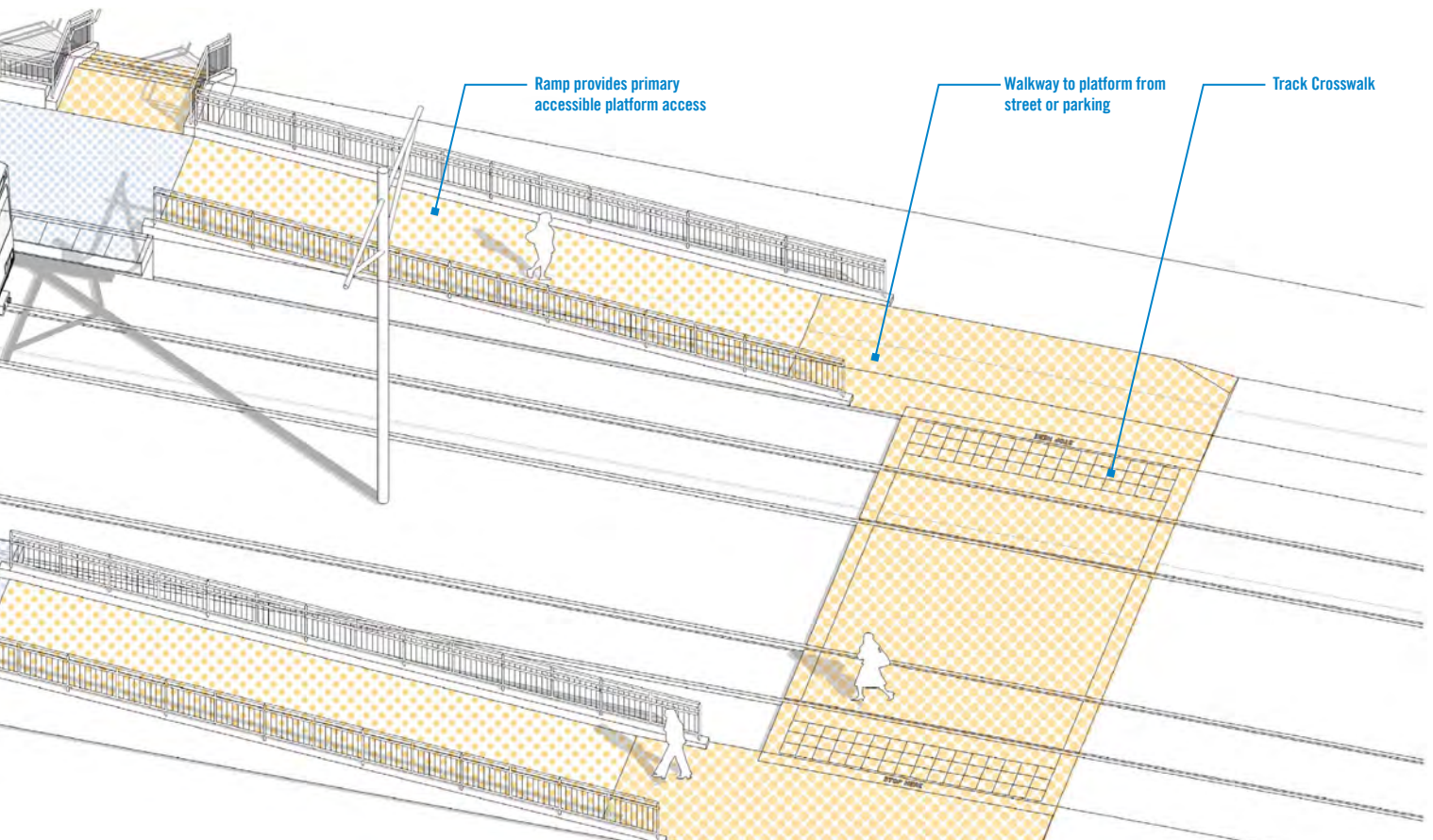

GUARDRAILS, HANDRAILS, & GATES

The station site and platform are equipped with guardrails, handrails, and gates as a means of protection against accidental falls, change in elevation, or to help direct passengers to and from the station in the safest manner possible. The building code, life safety standards, and accessibility guidelines provide a basis for guardrails and handrail requirements, and designers must be aware of various physical needs and abilities of patrons to ensure facilities provide universal access.

EXISTING

Types

There are several types of pedestrian guardrails and handrails throughout the system. The guardrails vary from decorative welded stainless-steel bar stock with vertical pickets at First Avenue Station, to painted steel pipe with round pickets and decorative forms at Station Square, to painted steel pipes with wire mesh infill at various other stations, to wood at smaller neighborhood stations.

Material

The materials mainly consist of painted steel tubing with welded joints, mesh, or vertical pickets and steel handrails.

Challenges

The diversity of designs and materials create a maintenance problem for the PAAC staff. Factors such as vandalism, corrosion, and aging damage the guardrails and handrails. The two major effects impacting the guardrails are vandalism and corrosion.

Opportunities

As the base of the railing system corrodes, the steel framing becomes unsafe and not stable and requires replacement. This provides an opportunity to replace the railing system with a more durable and corrosion resistant stainless-steel material that can withstand the salt and winter exposure much better than painted steel.

REPAIR

Repairing the guardrails, handrails, and gates is dependent on the level of corrosion and instability of the railing system. Where vertical support steel posts --which are typically embedded into concrete rails --are corroded, it is difficult to repair the damage. If a vertical support post is not corroded beyond repair, then the steel railing system can be repaired per the metal repair guidelines. Rust should be removed and the system re-painted.

REPLACE

Replacement of the guardrail and handrail system is a matter of safety. If vertical support posts are corroded beyond surface rust, then the overall railing system may be compromised. The OSHA and building codes require the rail to withstand 200 pounds

of vertical and lateral concentrated load at the top edge of the guardrail.

Several of the guardrails with wire mesh infill have been kicked out and/or severely dented, requiring replacement. The wire mesh is less durable than standard pickets, therefore easier to damage. The other main reason for damage is rusting or corrosion. This is most noticeable at locations where rock salt meets the metal guardrail. These locations are usually at the base of the posts or at the juncture where the base of the wire mesh sits in the perimeter channel that supports it. Likewise, at the end of most long elevated platforms, restricted access is provided to the rails. This access is intended for use by maintenance staff only and therefore is blocked by a gate. The gate is a single-swing, hinged gate that matches the aesthetic of the guardrail system at that station. The gate is typically 36 inches wide and 42 inches high. As with the guardrail system, some of the older gates are falling off the hinges or have been damaged over time and require maintenance.

NEW

Placement & Orientation

Guardrails, handrails, and gates are located within a station site based on passenger safety, security, pedestrian guiding, and accessibility. Any abrupt change in elevation where the higher portion is accessible makes a fall possible. Due to this responsibility and liability, guardrails are placed to protect people using the premises. Guardrails generally are required by code where there is a drop of 30 inches or more. Restricted access gates are located at the end of most elevated platforms to restrict access to only maintenance staff to the lower rails.

Size & Configuration

Guardrails and handrails in facilities are required by building codes in many circumstances. Building codes also require that no opening in a guardrail be of a size such that a 4 inches sphere may pass. There are some exceptions according to the IBC which allow openings to not exceed 8 inches or 21 inches depending on occupancy groups or special areas.



Use signage and color directly on end access and emergency exit gates.
Expo/Western Station, Los Angeles

In addition to utilizing stainless steel to reduce corrosion, it is recommended to elevate all guardrails on a minimum 8 inches high concrete curb. This will provide a buffer to keep de-icing salts from resting on the posts for extended periods of time, reducing the potential of rusting. (see guard details in appendix) To standardize and increase durability of the guards, it is recommended that the design/configuration of the guardrails be simplified to a basic design with 1.5-inch diameter top and bottom rails; 1.5-inch intermediate rail 6 to 7 inches o.c. from top rail; and .75-inch vertical pickets at 4 inches o.c. (see Guard Details in Appendix). This design will be more difficult to damage, reducing the likelihood of vandalism, and minimizing maintenance costs. This guardrail is constructed out of .06-inch thick stainless. It can be mounted using a base-plate or cored into the concrete curb to enhance the strength. Although significant damage would be unlikely, consideration should be made to design the guards in sections that can be removed and/or replaced to allow for easier replacement of damaged areas without replacing long sections of rail.

Construction

Restricted access gates should be designed to match the proposed guard rail system to provide a durable and consistent aesthetic at the stations. The hinge system should be heavy duty to allow for continued use with minimal maintenance. Highly legible warning signage should be securely mounted on the inside face of the gate to instruct pedestrians not to enter the restricted area. The signage should be coordinated with the station signage standards, and be of a durable, corrosion-resistant material.

Accessibility

Wherever pedestrian facilities are intended to be a part of the transportation facility, federal regulations (28 CFR Part 35) require that those pedestrian facilities meet ADA guidelines. All new construction or alteration of existing transportation facilities must be designed and constructed to be accessible to and usable by people with disabilities. Additionally, Section 504 of the Rehabilitation ADA require pedestrian facilities to be designed and constructed so they are readily accessible to and usable by people with disabilities.



To not interfere with passing trains, end platform fencing should terminate a safe distance away from the platform edge and utilize a perpendicular section to deter riders from passing around. Netherlands

Similarly, pedestrian facilities (and elements) require periodic maintenance to prolong the life of the facility and provide continued usability. Title II of the ADA requires that all necessary features be accessible and maintained in operable working condition for use by individuals with disabilities. Accessible handrails are required on stairs and on access ramps that have a rise greater than 6 inches. If the height of a drop-off (typically greater than 30 inches) adjacent to a pedestrian facility necessitates the need to protect pedestrians from falls, then a more robust railing system designed for fall protection should be used. If the drop-off is adjacent to either a stairway or an access ramp with a rise greater than 6 inches, then a combined railing system that meets the requirements for both accessibility and fall protection must be used..

Material

For ease of maintenance, durability, and longevity, it is recommended that all guardrails and railings be constructed of type 316 stainless steel. Type 316 contains 16% chromium, 10% nickel and 2% molybdenum. The molybdenum is added to help resist corrosion to chlorides (like sea water and de-icing salts). Additionally, the stainless steel requires no painting or additional finishing, making it very low-maintenance for PAAC staff.

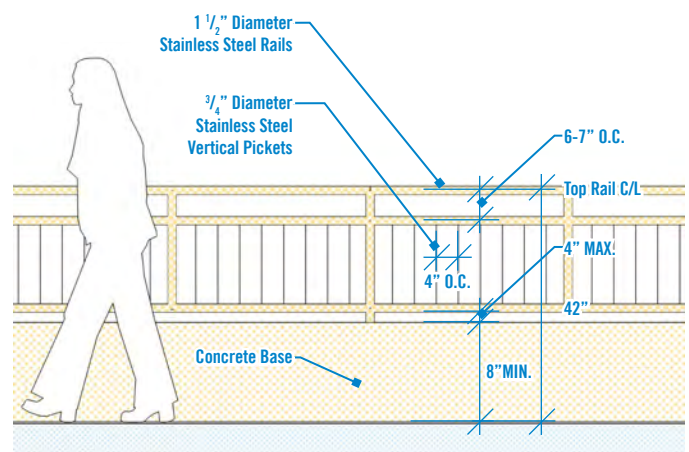
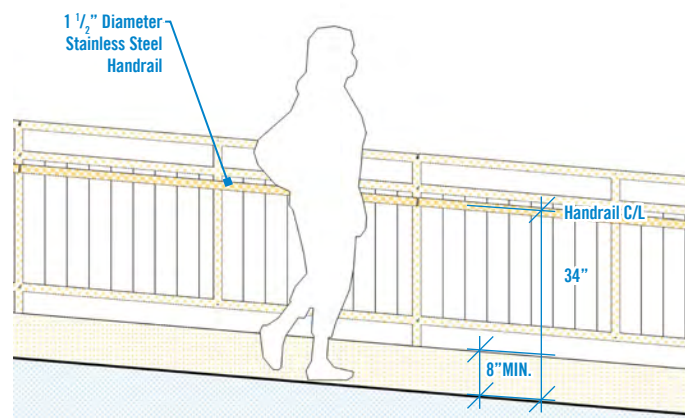

Typical ramp handrail (above) and guardrail (below) installation.

AT-GRADE TRACK CROSSING

At-grade track crossings are located throughout the LRT system to provide access to boarding platforms where alternate routes are not present. The need for the crosswalks are due to several factors including terrain, ease of access, accessibility, and cost.

EXISTING

Types

There are several types of crosswalks based on their material makeup and construction, but they all serve the purpose of crossing the tracks in a safe and accessible manner.

Material

Crosswalks are constructed of concrete, while others utilize wood railroad ties with rubber padding.

Challenges

Many crosswalks are in good condition, while others are in various states of disrepair and in need of maintenance.

Opportunities

When feasible, rubber or asphalt crosswalks should be replaced with concrete.

REPAIR

Repairing of crosswalks should occur when small areas are damaged, not level, or are cracking. Much like any other surface that provides access to and from the station, crosswalks must meet minimum code and accessibility standards for levelness and surface flatness. If there are uneven surfaces greater or cracks than half-inch repairs should be made.

REPLACE

Replacement of a crosswalk should occur if the surface conditions are damaged for greater than 50% or if the location constitutes an unsafe crossing for patrons.

NEW

Placement & Orientation

At several of the LRT stations, pedestrians need to cross the light rail tracks to access a transit station or stop. The design of these crossings is critical, as pedestrian/train collisions typically result in severe or fatal injuries. While most current standards and requirements for railroad at-grade warning systems are tailored to motor vehicle traffic, the Federal Highway Administration's Railroad Highway Grade Crossing Handbook provides guidance about pedestrian crossings. Additional guidance is provided in several other standards. Different standards apply to at-grade crossings of light rail tracks, which often have no gates or warning devices.

At-grade crossings with multiple tracks can present additional dangers to pedestrians when a train stopped on the near track limits the visibility of a moving train on the far track. Separate

warnings may be necessary for these locations to help alert pedestrians of the full extent of the danger of the at-grade rail crossing.

Light rail crossings occur in a wide variety of alignment configurations and operating environments. Typical railroad-style, gated crossings are not feasible in certain light rail environments. Planning and design objectives should include eliminating hazards where possible, then mitigating or warning where hazards remain. The approach should consist of the following:

- **Eliminate Hazards:** Hazards to the customers and public shall be identified, evaluated, and eliminated through planning and design where feasible. For example, the number of track crossings should be minimized. Line-of sight obstructions to oncoming trains should be avoided.
- **Mitigate Unavoidable Risks:** Where planning and design does not allow for elimination of hazards or unacceptable safety risks, safety treatments that mitigate those risks shall be provided.
- **Provide Warning Devices:** Where neither planning, design, nor safety treatments effectively eliminate identified hazards or adequately reduce associated risks, warning devices shall



Use textured warning pavers and red paint to define the pedestrian track crossing. Wardlow Station, Los Angeles



Consider incorporating upright signage, in addition to text on the ground, to define track crossing and ramps. Lents / SE Foster Rd Station, Portland

be used to alert people of the remaining risks and hazards.

Warning devices may be passive or active and can include:

- Traditional gate/flasher/bell assemblies
- Active or passive warnings – bells/whistles or signage

Size & Configuration

Walkways crossing rail tracks to reach a station platform should be level and flush with the top of the rail at the outer edge and between rails, except for a maximum 2.5-inch gap on the inner edge of each rail to permit passage of wheel flanges. Such crosswalks, which for obvious reasons cannot be provided with either curbs or railings, shall be defined by a continuous detectable warning strip 36 inches wide and in compliance with ADAAG Section 705, Detectable Warnings and 406, Curb Ramps. Crosswalks should be wide enough to accommodate the expected levels of pedestrian traffic. Narrow crosswalks that cannot accommodate the volume of foot traffic may encourage pedestrians to walk in the track bed or take alternate routes, increasing the potential for injury. It is desirable to provide a walk clear width (i.e., lateral space available for pedestrian travel for the length of a corridor) at least wide enough to accommodate two people walking side-by-side.

Construction

The full clear width of a crosswalk should be paved with a smooth, stable, and slip-resistant material to accommodate wheelchairs, bicycles, and strollers.

Accessibility

Wherever pedestrian facilities are intended to be a part of the transportation facility, federal regulations (28 CFR Part 35) require that those pedestrian facilities meet ADA guidelines. All new construction or alteration of existing transportation facilities must be designed and constructed to be accessible to and usable by people with disabilities. Additionally, Section 504 of the Rehabilitation ADA require pedestrian facilities to be designed and constructed so they are readily accessible to and usable by people with disabilities.

Good pedestrian design also should account for the needs of all potential users, including those with physical or mental limitations. The Americans with Disabilities Act Accessibility Guidelines (ADAAG) describes the minimum designs for providing accessibility for all pedestrians.

Material

For ease of maintenance, durability, and longevity, it is recommended that all track crosswalks be constructed of concrete.

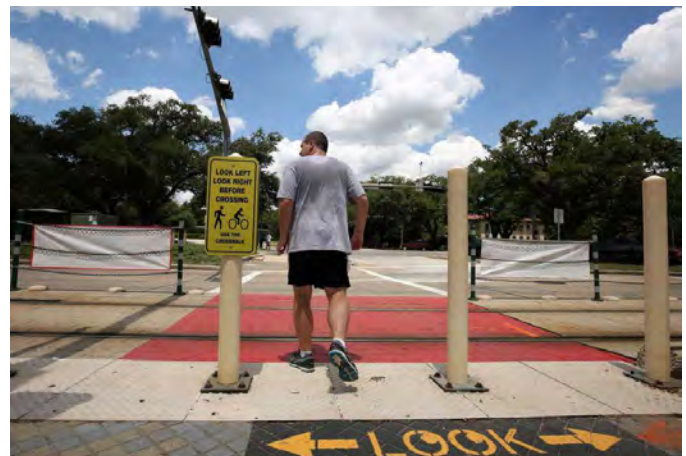
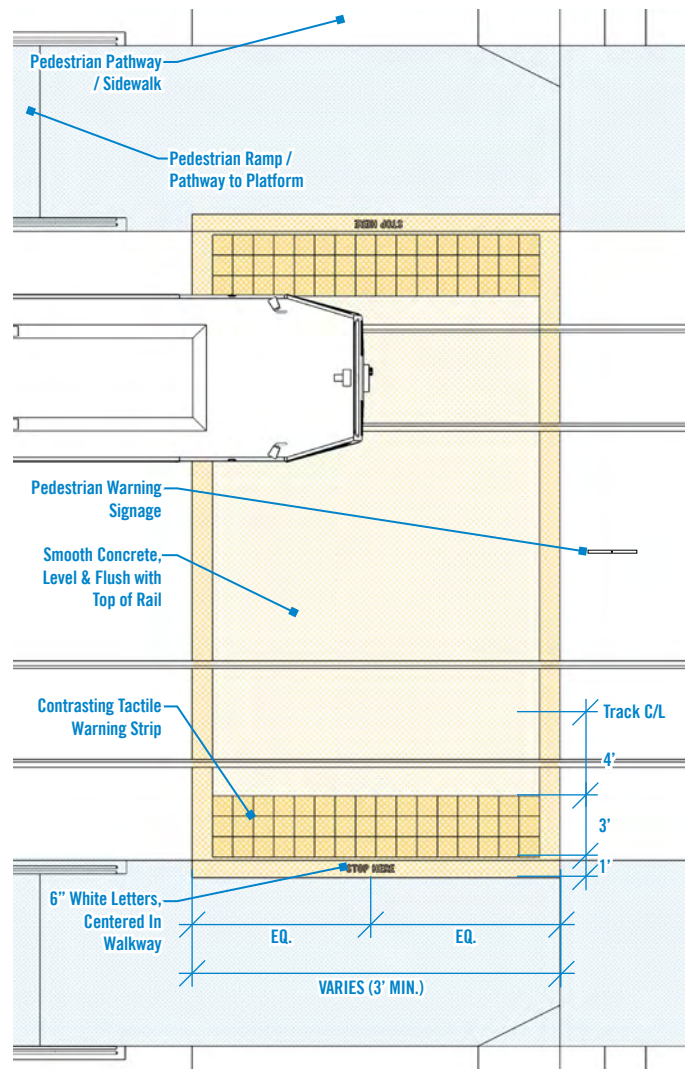

At track crossings near vehicular intersections, consider adding additional pedestrian safety elements such as bollards and signage.
Harmann Park / Rice University Station, Houston

BETWEEN CAR BARRIERS

The high-level elevated platforms within the system currently have between car barriers installed along the platform edge for rider safety. The existing barriers have varying height uprights with reflective tape around the top. The barriers are designed to alert visually impaired riders that the space between the cars is not a door opening, thereby deterring them from entering the area between the cars and falling to the rails below.

EXISTING

Types

The system currently has one type of between car barriers. The product utilizes a spring system that allows the unit to be traversed by wheelchairs or maintenance vehicles in the event of errant docking.

Material

The barriers are made of yellow plastic tubes of varying heights and with reflective tape on the top of the tubes.

Challenges

The barriers occasionally are broken and need to be replaced.

Opportunities

The between car barrier standard is appropriate and does not need to be modified.

REPAIR

Between car barriers should be repaired as needed according to manufacturer.

REPLACE

Between car barriers should be replaced as needed according to manufacturer.

NEW

Placement & Orientation

The barriers are designed for elevated platforms and level boarding conditions with consistent rail car length. The barriers should be fully customizable for length and height of required uprights and placed between the LRT vehicles.

Size & Configuration

Post shall be of varying heights of 26 inches and 36 inches alternating.

Construction

The color should be safety yellow and the top shall have reflectors. Quick and easy installation is preferable. The barriers should be durable, made of a material that is low-maintenance, resist corrosion, and meets UL 94 V-0 standards for fire retardancy.

Accessibility

Department of Transportation regulations implemented the transportation provisions of the 1990 ADA. There are between car barrier requirements for all types of rail vehicles, but these requirements are specific to light rail vehicles and systems. Under 49 C.F.R. § 38.85, where light rail vehicles operate in a high-platform, level boarding mode, devices or systems must be provided to prevent, deter, or warn individuals from inadvertently stepping off the platform in between cars. The intent of this provision, is to require light rail systems to obtain suitable devices to assist with and prevent passengers from mistaking the gap between cars for a doorway and potentially falling onto the trackbed. The requirements address the need to mitigate the hazard of a gap created between two or more rail cars. All travelers must have safe, unimpeded access to a light rail system. In a level boarding/platform environment without between car barriers, the hazard of falling to the trackbed exists whenever a light rail system operates trains of more than one car.

Material

Safety yellow and fire-retardant plastic material.

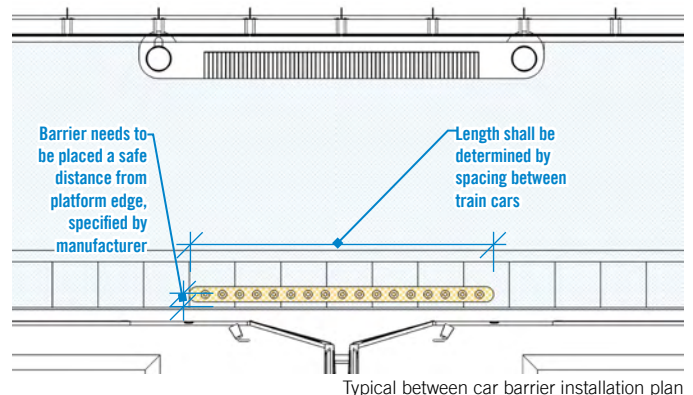

Existing standard between car barrier at McNeilly Station, Pittsburgh

SALT STORAGE

The climate in Pittsburgh region dictates the need to remove and/or prevent snow accumulation on walkways, ramps, and platforms throughout the LRT system. PAAC maintenance staff have determined that the most efficient and cost-effective manner to combat this issue is using rock salt. The most efficient way to manage and handle the salt is by purchasing bags and storing them at each location. The bags are currently stored in large plastic yellow storage bins on platforms or areas adjacent to the walking surfaces to be treated.

EXISTING

Types

There is only one type of salt storage bin.

Material

The material is plastic as determined by manufacturer.

Challenges

The greatest challenge is locating the bins to allow easy access, and not impeding platform and station access.

Opportunities

The opportunity exists to consistently locate the salt storage bins and provide for a more attractive bin.

REPAIR

Repair of storage bins is not applicable.

REPLACE

Salt storage bins should be replaced as needed, according to condition of the bins.

NEW

Placement & Orientation

The salt storage should be located on the platform but opposite of the main entry point and not impeding clear widths of 4 feet minimum.

Size & Configuration

The proposed storage bin that is recommended for use at the platform and other locations is based on the SOS Storage Bin. The bin dimensions should be a minimum of 48" long x 33" deep x 34" high and should be a thick, durable plastic that can withstand abuse and vandalism.

Construction

The bin should be lockable with a padlock, although most of the units will not be locked. It should be rotomolded with a double wall lid for a long life; should include fork channels to allow for fork lift movability; should have a stackable and nestable design to save on storage space and shipping; and should stand up to severe climate and weather conditions. Finally, the unit should be gray or a color that coordinates with the selected color palette.

Accessibility

Not applicable.

Material

As determined by manufacturer.



Existing mid-platform salt storage bin at Station Square limits accessibility, blocks sight lines, and attracts debris accumulation.



Existing mid-platform salt storage bin at Dormont Station is placed at the end of the platform, out of the way of pedestrian accessibility and clear of sight lines.

STATION PROPERTY

Overview

The rider experience begins with the station property, which provides connections between the transit platform and the broader public realm. Existing station properties vary significantly, ranging from narrow constricted sites to large parcels with integrated commuter parking. Station property elements are not found at every station, but should be considered according to station type and allowable space.

Station Property Elements

- Public Entry Plaza
- Site Lighting
- Planting Design
- Public Art
- Adjoining Bus Shelters
- Bicycle Parking
- Bike-share Station
- Passenger Drop-Off Area
- Retail Kiosk
- Commuter Parking Connection



Station entry plaza, Charlotte



Commuter and bicycle parking, Rochester



Planting and public boat sculptures in Portland

Station Property

- A** Public Entry Plaza
- B** Site Lighting
- C** Planting Design
- D** Adjoining Bus Shelters
- E** Bicycle Parking
- F** Bike-share Station
- G** Passenger Drop-Off Area
- H** Salt Storage
- I** Commuter Parking Connection

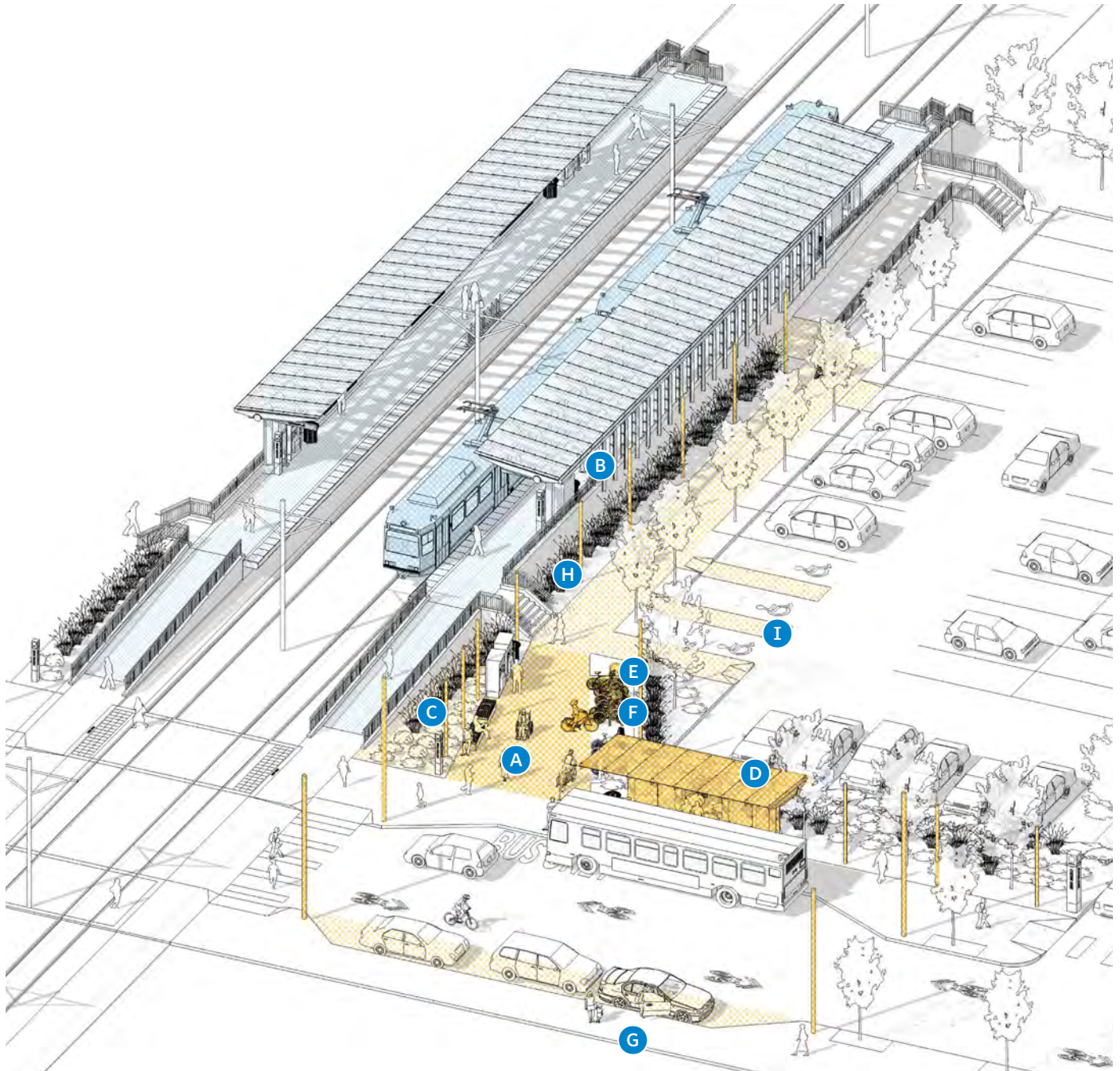

PUBLIC ENTRY PLAZA

Programmatically, plazas are the “public face” for the station that welcomes and orients riders. They should be designed and oriented to allow safe, easy, and straightforward access to and from the boarding platforms. Designers are urged to utilize appropriate materials, furniture, signage, and art to reflect the public nature of the space.

EXISTING

Types

Multiple stations within the PAAC LRT system have public entry plazas. The existing plazas vary in size, arrangement, materials, etc. and are mainly intended as a pedestrian site arrival point for the LRT station. Some plazas include seating and shelters that may not enhance or make the environment as welcoming as intended.

Material

The plaza surfaces consist of differing materials, such as cast-in-place concrete, exposed aggregate concrete, and brick pavers. The main surface material is cast-in-place concrete, while the other materials are used sparingly in higher profile locations.

Challenges

Due to heavy use of salt during the snowy winter months the walkways, ramps, and stairs are often heavily corroded and need replaced.

Opportunities

Replacing damaged or failing plaza surfaces, etc. provides an opportunity to reconfigure and improve access and accessibility to the station and platforms. Opportunities exist to improve the design and/or use of the plazas by making them more welcoming. This may require the removal of unused or underutilized shelters, etc.



Existing entry plaza at Willow Station, Pittsburgh is narrow, constricted, and cluttered.

REPAIR

Maintenance of the plazas is critical to prolong longevity, but all materials deteriorate with time. Many of the plazas are constructed of concrete; therefore, it is recommended that the same repair methods identified for concrete repair (Chapter 3.2) be utilized in those locations. For exposed aggregate concrete, similar techniques can be utilized, but the joint sealant should match the concrete color.

Masonry pavers pose different issues with regard to repairs. Damaged pavers are small enough to be replaced in kind if the materials can be located. In the event that the pavers cannot be matched, it is recommended that an acceptable pattern be developed to allow the replacement pavers to be integrated aesthetically.

REPLACE

As with concrete repair, it is recommended that the same methodology be utilized (Chapter 3.2) with regard to determination of whether to repair or replace surface materials at the plazas.

NEW

The design team must ensure that landscaping, level changes, or other architectural barriers do not prevent users from accessing the station platform or other amenities within a public plaza. This includes access to public art, seating, and other fixed “furniture.” The plaza should be designed to comply with all applicable codes and requirements including ADA. Additionally, pathways should be designed to get passengers to their destination in the most practical and direct manner. This is the most efficient and cost-effective solution and reduces the development of “goat” paths throughout the site.

It is preferred that concrete and masonry surfaces be utilized at new plazas. Concrete and masonry surfaces can be easily designed with compliant slopes that meet accessibility standards and properly direct rainwater. In addition, concrete and masonry surfaces are less expensive to maintain.

It is important to ensure that routine maintenance of landscape elements and artwork in plazas can be performed at a reasonable cost. Materials for outdoor amenities and furniture should be very durable and resistant to the elements and vandalism. Metals that do not require repainting are recommended.

To prevent vehicles from accidentally or intentionally entering a plaza from adjacent public streets, it is recommended that barriers be installed, where deemed necessary, along the border of the plaza. These barriers can be simple bollards, decorative guards, or fixed landscape elements.



Stations with limited property can utilize platform adjacent entry plazas to directly connect public right-of-ways with the platform. CTC Station, Charlotte



Entry plazas should be visually open, incorporate color and lighting, and have sight lines to the platform. Downtown Santa Monica Station, Santa Monica

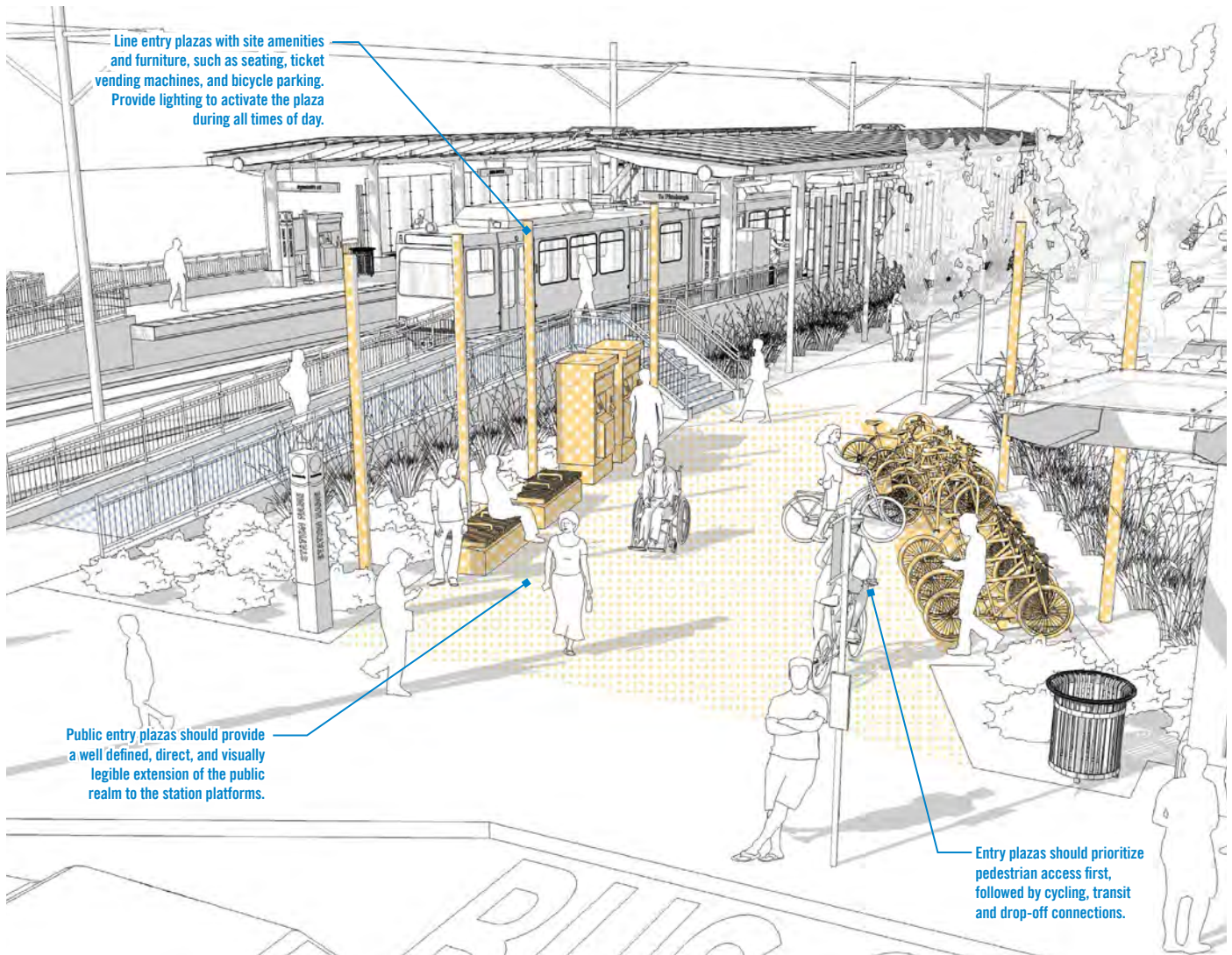

SITE LIGHTING

Lighting is critical to the design and experience of a space. Lighting fixtures can be designed to enhance the aesthetic design of a space or can provide dramatic patterns of lighting. Proper lighting influences how patrons feel about the stations and ultimately influence ridership. Appropriate lighting levels can promote safety and security at stations by discouraging derelict behavior, making tripping hazards more obvious, and providing adequate lighting levels for proper site surveillance. Lighting can also assist wayfinding and improve accessibility for all.

EXISTING

Types

There are various types of site lighting poles, fixtures, and lamps located at the LRT stations throughout the system. Poles are aluminum, painted or galvanized steel, and wood. Fixture types include direct, indirect, and a combination of the two. Lamps include metal halide and newer LED.

Material

Most fixtures are constructed of aluminum with glass or polycarbonate lenses.

Challenges

Because of the varying types of fixtures at the multiple stations, there are challenges with creating consistency throughout the system. This creates a problem with maintenance and upkeep. Also, the lamping varies by fixture type creating inconsistency as lamps are replaced.

Opportunities

Replacing lamps creates an opportunity to change all fixtures to LED energy efficient fixtures. The LED lamps can provide more lighting (security) at locations that need upgraded. Also, if feasible the lighting fixtures can be replaced with a new fixture palette that can modernize, as well as standardize, fixtures across the system.

REPAIR

The existing steel poles that are painted or galvanized may be repainted or cold galvanized as necessary. Refer to the “Primary Materials: Metals” in Section 3.2 of these LRT Station Design Guidelines for additional information.

REPLACE

Refer to the “New Site Lighting” section of these guidelines and the “Primary Materials: Metals” in Section 3.2 of these LRT Station Design Guidelines. The existing wood poles should be replaced with new light poles and fixtures as outlined in the “New Site Lighting” section of these guidelines.

NEW

Requirements

Lighting should be energy-efficient, vandal-resistant, and minimize life-cycle costs. To conserve energy, automatic timers / ambient light sensitive controls should be activated upon ambient illuminance of less than 10 fc at the ground plane. The minimum number of light fixtures will be determined by the required lighting levels. Minimum illumination levels for sidewalks and parking lots should be 5 fc at the ground plane. In the event of a power outage, emergency lighting should be adequately located to permit safe egress from the site for all patrons.

Placement

Locations of site lighting poles should not impede circulation of vehicles or pedestrians. Poles should be coordinated with adjacent landscaping and site design to protect the poles from damage and ensure that landscaping will not obscure the intended performance of the light fixture.

Applicable Codes

Illuminating Engineering Society of North America (IESNA)
Americans with Disabilities Act Accessibility Guidelines (ADAAG)
National Electric Code (NEC)
Life Safety Code (NFPA 101)
Underwriters Laboratories, Inc. (UL)



Site lighting should also visually help lead users along primary paths by creating a line of light. Lower bollards or step lights are more focused and directional.

Site Lighting Design Principles

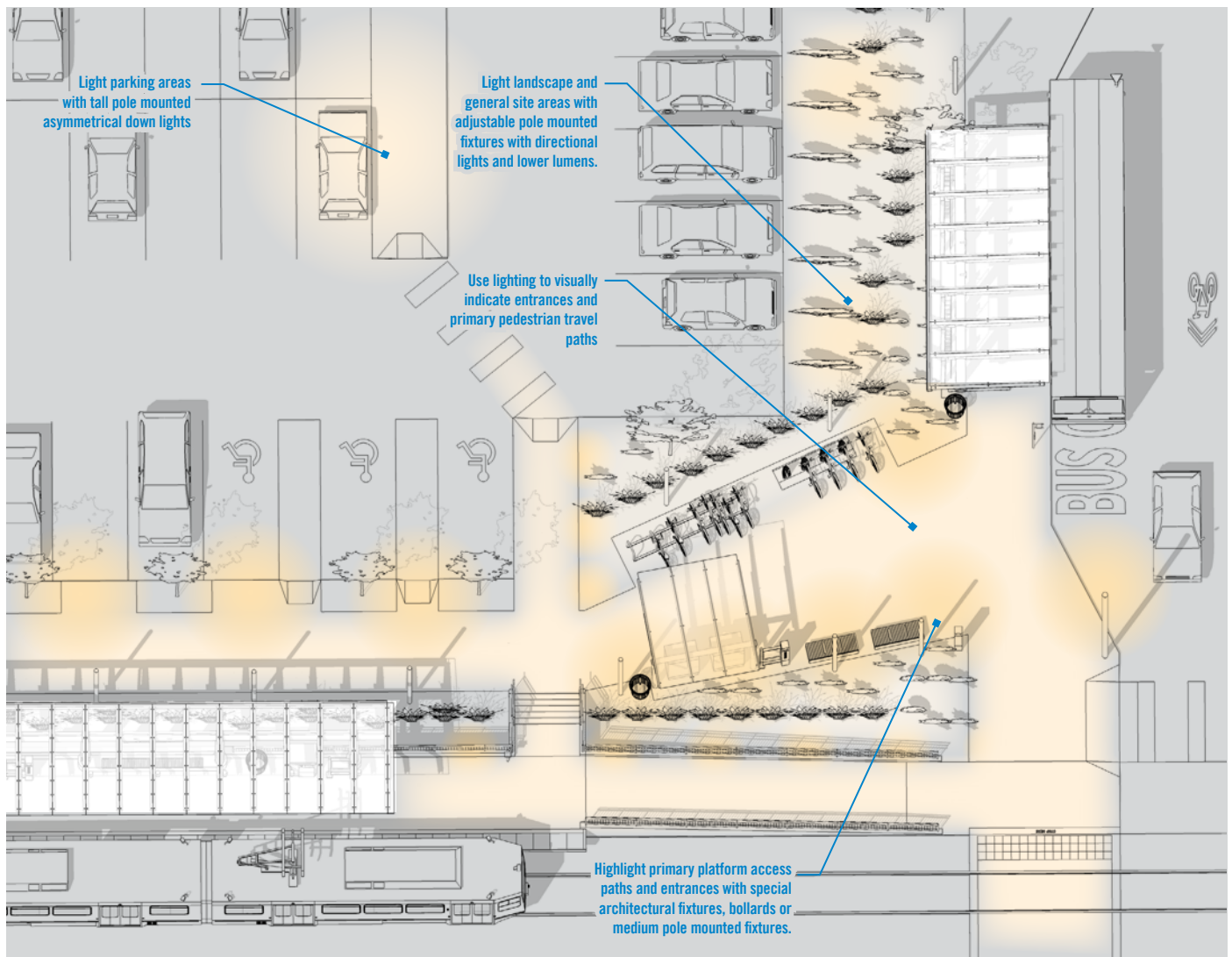

Example Site Lighting Family

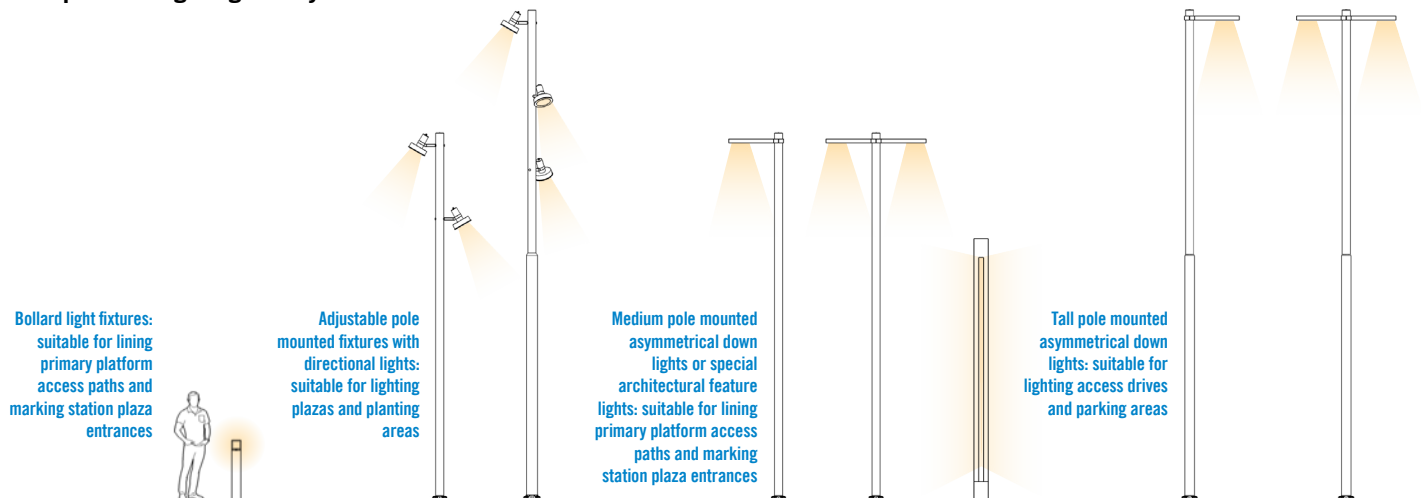

PLANTING DESIGN

Successful planting design creates an aesthetically pleasing environment for users, and when planned appropriately, can reduce maintenance needs while benefitting the ecological environment. While visually adding variety and pleasantness to the rider experience, plantings also psychologically improve rider comfort. For example transit riders perceive their wait to be shorter when trees are present. A well-designed planting scheme also enhances the pedestrian realm, defining walks and plazas with a variety of perennials and grasses, interspersing shade trees to provide summer sun relief, and establishing hedgerows to create vistas and wind buffers.

EXISTING

Types

Various types of plantings exist throughout the LRT system. The plantings include various grasses and shade trees.

Challenges

Maintenance of the plantings is the major challenge. For the stations to feel welcoming, it is important for the plantings look well-maintained and not overgrown or sickly.

Opportunities

If upgrading the plantings at any stations, the opportunity exists to install plantings that require low to no maintenance. The new plantings can be designed to make stations more welcoming and aesthetically pleasing.

NEW

When selecting plant material, careful consideration should be placed on what plants are selected and where they will be located. By matching a plant species to its preferred soil type and sun needs, a low-maintenance landscape can be established.

Native planting

Plant materials selected should be native or naturalized in order to conserve water, provide habitat for pollinators and reduce maintenance. Plantings should be low maintenance materials that do not need to be moved. Drought and salt tolerant plant species that provide overlapping bloom periods and visual interest should be selected for planting beds. Where space allows, shrubs and ornamental trees provide additional structure and variety within the public realm.

Hillside Planting

Due to the severe topography changes in region, many plantings throughout the LRT system is located on hillsides. New plantings occurring on hillsides should control erosion and be low maintenance.

Maintenance

Low-maintenance plant material shall be selected to reduce the need for watering once established. Perennials and grasses, once established, will need little maintenance. Grasses do not need to be cut down before winter. They may provide winter interest if left in place. Foliage should be cut back to 4 to 6 inches in the spring before growth resumes. When foliage is removed, spring growth will begin earlier.

Salt Tolerant Plant List

The following list contains plant species that are highly tolerant of salt. Species should be selected with final growth size in mind. Some species below need a larger root zone to thrive. This list should be considered when planting adjacent to roadways.

Shade Trees

The environmental, social, and economic benefits of shade trees are well-documented, and they should be incorporated into planning efforts. Shade trees add economic value to adjacent properties and enhance the pedestrian realm by cleaning the air and providing shade from the summer sun. When planting shade trees, the location of utility lines should be considered, and where conflicts occur, utility line compatible trees (with mature heights less than 25 feet) should be selected.

Trees planted shall be:

- Planted where no overhead utilities exist. Shade trees are the most desirable size of tree for planting, and should be used at all times in the absence of overhead wires. Where necessary, offset trees so they are not directly under the wires.
- Two-inch caliper (minimum) measured 6 inches above the root ball. The rootball level should be set slightly above soil grade (1 to 2 inches), with the finished soil grade being 2 inches below the top of the sidewalk.
- Mulched with 2 inches of shredded wood mulch for weed control.
- Staked just below the first branch with 1- to 3-inch-wide polypropylene straps (two per tree on opposite sides of tree, connecting from tree to stake horizontally). Rope or wire through a hose should NOT be used. ArborTie is an acceptable product. A date should be noted on the stake depicting when the trees were installed.
- Inspected after 1 year, and all staking materials removed, or as otherwise directed by the City Forester.
- Planted in planting beds, and measuring a minimum of 3 feet by 10 feet to assure space for the root zone. Where box style planting beds currently exist, the space shall be enlarged to the above dimensions. The rectilinear shape may be substituted with Forestry approval, but a minimum of 30 sq. ft. of root zone must still be observed. Trees require ample root space for optimum growth and longevity, so planting beds larger than the minimum are welcome and desirable where there is still sufficient space for pedestrian traffic.

Shade Trees

Aesculus hippocastanum - Horsechestnut
Amelanchier canadensis - Serviceberry
Betula lenta - Cherry birch
Crataegus crusgalli var. *inermis* - Cockspur hawthorn
Ginkgo biloba - Maidenhair
Gleditsia triacanthos var. *inermis* - Honeylocust
Gymnocladus dioica - Kentucky coffeetree
Hamamelis spp. - Witchhazel
Juniperus virginiana - Eastern redcedar
Magnolia spp. - Magnolia
Nyssa sylvatica - Black gum
Quercus alba - White oak
Quercus rubra - Red oak
Sophora japonica - Japanese pagodatree
Taxodium distichum - Baldcypress



Shade trees should be multi-stem, creating more character and structure. *Amelanchier canadensis* (Serviceberry) shown.

Shrubs/Groundcovers

Arctostaphylos uva-ursi - Bearberry
Aronia spp. - Chokeberry
Caragana arborescens - Siberian pea shrub
Cornus racemosa - Gray dogwood
Cotoneaster divaricatus - Spreading cotoneaster
Cotoneaster horizontalis - Rock cotoneaster
Cytisus scoparius - Scotch broom
Hibiscus syriacus - Rose-of-Sharon
Hydrangea spp. - Hydrangea
Hypericum spp. - St. Johnswort
Philadelphus spp. - Mockorange
Potentilla fruticosa - Potentilla
Ribes alpinum - Alpine currant
Rosa rugosa - Saltspray rose
Rhus spp. - Sumac
Syringa spp. - Lilacs
Vaccinium spp. - Blueberry/cranberry



Consider the year-round aesthetics of plantings, selecting for fall foliage or spring flowers. *Aronia* spp. (Chokeberry) shown.

Perennials

Armeria maritima - Sea thrift
Calamagrostis acutiflora - 'Karl Foerster' reed grass
Dianthus gratianopolitanus - Cheddar pink
Festuca glauca - 'Elijah Blue' Blue Fescue Grass
Helleborus orientalis - Lenten rose
Hemerocallis spp. - Daylily
Iberis sempervirens - Candytuft
Limonium latifolium - Sea lavender
Liriope spicata - Lilyturf
Pennisetum alopecuroides - Fountain grass
Sedum spectabile - Sedum 'Autumn Joy'
Schizachyrium scoparium - Little bluestem
Waldsteinia fragarioides - Barren strawberry
Yucca filamentosa - Adam's-needle Yucca



Vary textures and colors to create more interesting bands of plantings. *Calamagrostis acutiflora* (Karl Foerster reed grass) shown.

PLANTING DESIGN EXAMPLES



Use low, durable plantings adjacent to areas with traffic conflicts & intersections to maintain clear sight lines. S-Line, Salt Lake City



Consider low-maintenance, flowering plants to accent planting areas. East Liberty Station, Pittsburgh.



Utilize adjacent rooftop structures and disconnected downspouts for rainwater irrigation. Perkins Green Student Housing Complex bus shelter, Rochester



In place of safety fencing, couple planting and public art, such as sculptures, to act as barriers and safety separation. SE 17th Ave & Rhine St. Station, Portland



Investigate opportunities for green guideways, which provide permeable surface for stormwater infiltration and retention. Avinguda Diagonal, Barcelona



For long, linear planting areas, incorporate banded planting patterns to create visual rhythms and interest. Orange Line, Portland

Planting Design Principles

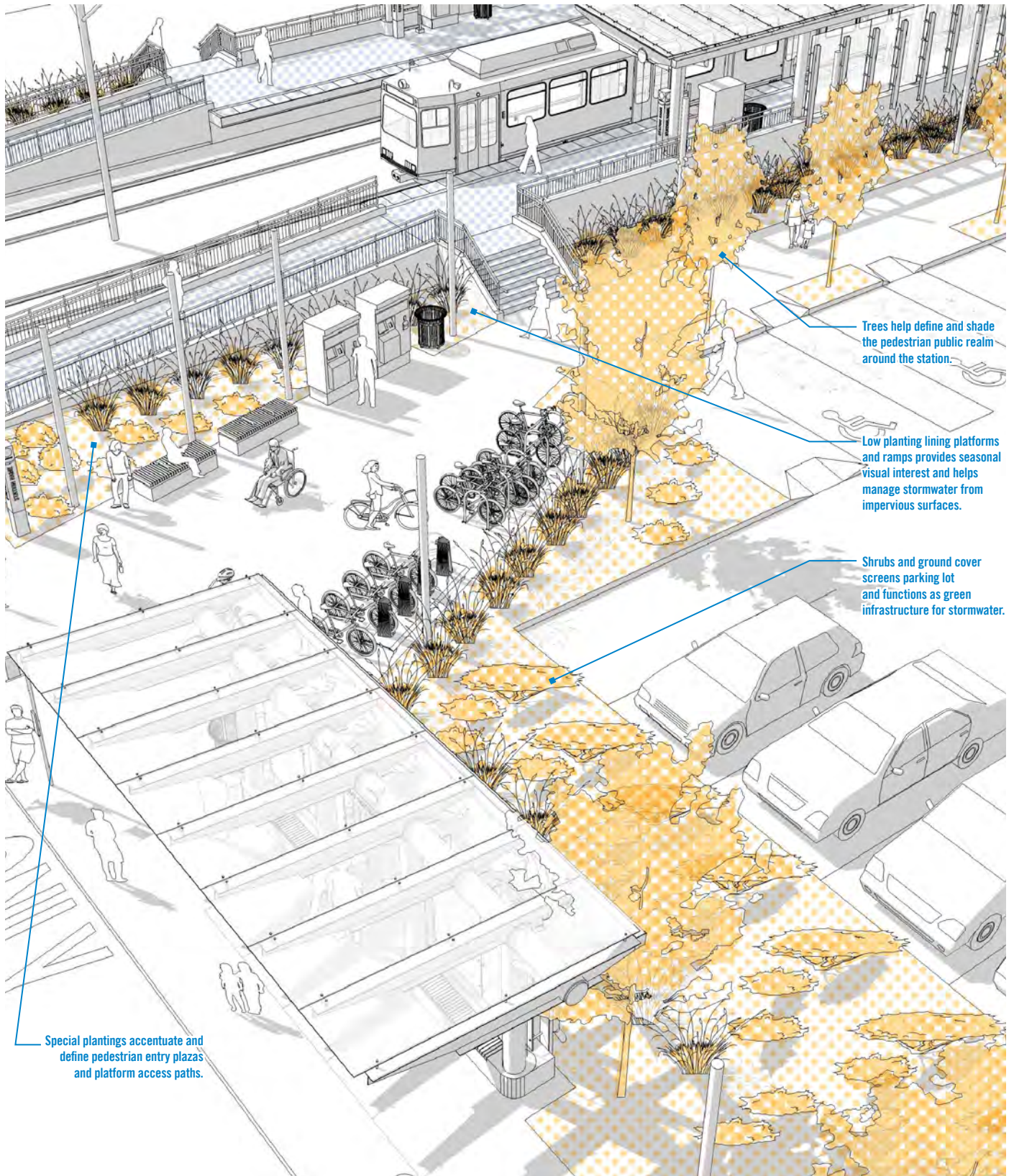

Trees help define and shade the pedestrian public realm around the station.

Low planting lining platforms and ramps provides seasonal visual interest and helps manage stormwater from impervious surfaces.

Shrubs and ground cover screens parking lot and functions as green infrastructure for stormwater.

Special plantings accentuate and define pedestrian entry plazas and platform access paths.

PUBLIC ART

The Federal Transit Administration (FTA) encourages the inclusion of art in transit systems by stating, “The visual quality of the nation’s mass transit systems has a profound impact on transit patrons and the community at large. Good design and art can improve the appearance and safety of a facility, give vibrancy to its public spaces and make patrons feel welcome.”

In 1995, the FTA established policies affirming the appropriateness of spending federal moneys on art and architecture in the design and construction of major transportation facilities. Mass transit systems should be positive symbols for cities, attracting local riders, and tourists. Good design and art can improve the appearance of a facility, and make patrons feel welcome. Art and architecture can be used to soften the related and unavoidable impacts of transit facilities and can be used to inspire community ownership of the facility.

Building communities that rely on transit and walking will require greater attention to humanizing transit stations and integrating them into their surrounding context. Public art plays a role in this process: it can help make transit stations more than just places to wait. Reinforcing the image of transit as a community amenity requires recognition of and sensitivity to the fact that the quality of the transportation experience directly affects the quality of the lives of transit users. Spaces that serve to accommodate waiting, as well as sidewalks and paths to stations that connect surrounding activity centers and land uses to transit, can be more interesting and made more secure by including public art in their design. Public art can draw out the identity of a space, and aid the understanding of the historical or cultural significance of a neighborhood and its residents.

EXISTING

Types

Outside of the downtown underground stations, currently public artwork exists at the South Hills Junction (SHJ) and a few other light rail stations. The public artwork at SHJ consists of various wall mounted paintings from various artists.

Materials

Currently, only painted panels are being utilized at the SHJ site.

Challenges

Challenges that exist include finding the proper and adequate locations for public art to allow for public viewing, as well as providing protection for the art from the weather and/or vandalism.

Opportunities

Public artwork can enliven the platform; provide pleasant backdrops to areas that can be otherwise mundane; provide interest for the patrons; and create a piece of art that can be celebrated for years.

REPAIR

There is currently minimal public artwork at LRT stations in the system; therefore, limited to no repair is currently required. As the artwork ages and more artwork is included throughout the system, maintenance and repair according to the artworks’ character will be required. The methods and party responsible for maintenance should be clearly outline in an agreement with the artist prior to creation and installation. The cost of installation, repair, and maintenance of the artwork must also be considered.

REPLACE

If and when it is deemed necessary to remove and/or replace existing artwork within any station, special consideration should be made. The removal and replacement of existing art should take into consideration the type of art, the artist’s desire to retain, the difficulty in removal, the care required to protect the art, and what will replace the art. This must also be considered within the artist agreement.

NEW

Placement & Orientation

Public artwork should be placed to provide the greatest impact to the patron while carefully being coordinated with other elements of the guidelines and with the overall design of the station. Art provides the opportunity to reduce negative impacts related to noise and visual barriers and help effectively strengthen the overall goal of providing clear pathways and visual clues to entry points and wayfinding needs.

At park-and-ride locations, design professionals should strive to design structures and facilities that both inspire current populations as well as future ones through their artistic and architectural elements. A second reason to include artistic elements in transit and park-and-ride design is that art if done properly can reduce vandalism. Inclusion of art in transit facilities can encourage a community to take ownership of the facility, increasing the public watchfulness over the investments placed at the facility or park-and-ride lot. Successful public art is well-integrated with its surroundings to enhance rather than disturb its environment.

Public art can take many shapes and forms: sculpture, paint fencing, and lighting, among other features. It can be the backdrop on site walls, decorative paving, painted walkways, signs, shelters, windscreens, etc. The locations can be park & rides, pathways to the transit facility, entry plazas, and elements on the boarding platforms including the canopies. All designs must be safe and welcoming for all. Installation should not interfere with boarding of transit vehicles, and designs should be suitable in size, scale, and materials for the requested location. Materials must be safe and able to meet maintenance and lifespan expectations. It is recommended that any artwork be approved by a joint PAAC and community panel prior to being installed on site.

Size & Configuration

The art size and configuration shall be coordinated with the station design team early during planning phase, so the greatest integration of design elements and common design approach can be achieved.

Construction

The artwork must be of high quality, be site-specific and require minimum maintenance to resist graffiti and vandalism.

Accessibility

The artwork should not conflict with any mobility or visual accessibility requirements. Careful consideration should be given to how the art should be experienced and if patrons with physical limits have access to and cannot conflict with the artwork.

Material

The artwork materials should be durable and apply with the same general principles and material considerations as any other station elements, including maintenance cleaning and salt or other weather exposure.



Explore different heights and inaccessible areas to place public art. Ellen Forney's Crossed Pinkies mural at Capitol Hill Station, Seattle



Incorporate public art into required property infrastructure, such as fencing & lighting. Fred Wilson's guardrail at Jersey Ave. Station, Jersey City

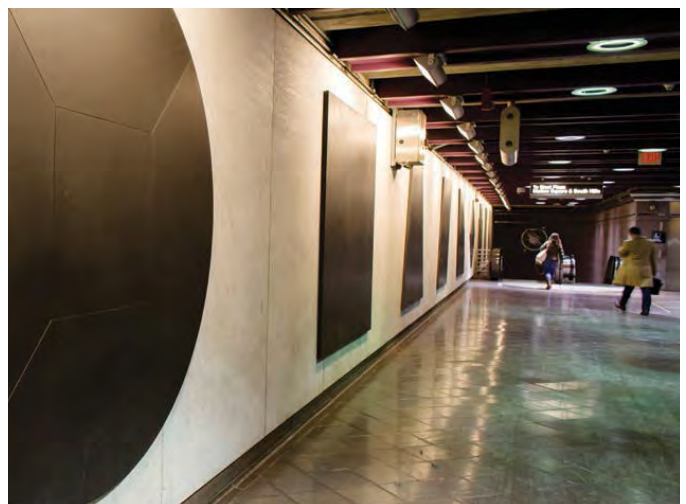

Apply public art to draw the rider's attention & interest to key, specific station areas. Sol Lewitt's Thirteen Geometric Figures at Wood Street Station, Pittsburgh

ADJOINING BUS SHELTERS

Various stations throughout the LRT system serve as an intermodal connection between the rail system and the bus system. The riders, transferring between the modes of transportation, need a place for waiting and protection from the weather.

EXISTING

There are several types of bus shelters within the PAAC LRT system. Some of the bus shelters are utilized as passenger weather protection at smaller LRT stations. This is an alternative to constructing a much more expensive canopy structure at these locations. This section does not encompass the shelters located on the rail platforms; it relates to the curbside bus shelters adjacent to existing LRT stations that function as an intermodal connection between the rail system and bus system. As the two modes of transportation are not always synced, it is important to provide riders an area for waiting and protection from the weather. Integrated bus shelters are provided adjacent to the rail stations at designated bus stops.

Types

The existing bus shelters vary in size, arrangement, materials, etc. Some shelters are premanufactured, off the shelf, constructed of extruded aluminum and polycarbonate. Some are custom fabrications constructed of steel frame with a metal roof structure. Others are constructed of precast piers, metal structures, and a metal roof to match the design and construction of the LRT station canopy.

Material

The materials used are extruded aluminum, steel, concrete, and polycarbonate.



Place adjoining light rail and busway stops direct & close to each other to facilitate transfers and limit confusion. South Hills Junction Station, Pittsburgh

Challenges

Due to the climate of Pittsburgh and heavy use of salt during the snowy winter months some of the shelters are corroded and need to be repaired or replaced. Additionally, some of the seating or wall panels are subject to vandalism of some sort, so upkeep and maintenance can be a concern.

Opportunities

Unnecessary and/or unused shelters should be removed or avoided to create space or opportunities to make entrance plazas more inviting, for example at McNeilly Station. Replacing damaged or failing shelters with new shelters that meet the proposed guidelines provides an opportunity to improve performance and reduce maintenance cost.

REPAIR

The bus shelters are subject to weather, sunlight, and other forces that cause damage and deterioration. The humid and wet climate can cause the metallic elements to corrode and rust. The deicing salts utilized to combat snow and ice also increases the rusting process. UV from sunlight can cause the polycarbonate roofing and windscreens to fade and/or discolor. Additionally, vandalism is another factor that causes damage or produces unsightliness.

Depending on the type, amount, and severity of the damage at each shelter, differing solutions must be employed according to PAAC maintenance guidelines for similar property and locations throughout the system.

REPLACE

Replacement of the bus shelter materials is problematic. Although the polycarbonate surfaces can be easily replaced, the remainder of the surfaces are difficult to replace without warranting full replacement of the shelter.



Station adjacent bus stops should feature a shelter or canopy that relates to the light rail station design & architecture. Wood Street Station, Pittsburgh

NEW

A good bus shelter is one that is well-located, has low maintenance requirements, and is vandal-resistant. It also should allow visibility and easy access to the bus, is comfortable and convenient, provides clear information, and is safe.

Location

Bus shelters associated with rail stations should be located in a position that allows for easy, straight-forward, direct access from the rail platform, if possible. The shelters should be located so riders do not have to cross vehicular traffic to get from the station to the shelter. The route between the station and the bus stop shall be ADA accessible, and as visually unobstructed as possible.

For general placement and orientation of bus shelters from curb lines and crosswalks, PAAC standard and federal standards should be followed.

Design

Bus shelters should be aesthetically consistent with its partner station canopy and platform to extend the visual consistency of the PAAC brand and emphasize the multimodal network. This contextual similarity may be considered in the shelter's materiality, the shelter's color palette, or the shelter's architecture.

Where ridership is low, or there are budget constraints, prefabricated, standard PAAC bus shelters should be used.

Lighting

Lighting, aside from providing safety, can be used as a tool to visually connect the station and the bus stop. Similar to Site Lighting principles (see section 3.4), the light fixtures should be consistent in design and highlight the preferred route between the

station and bus stop.

Signage

Clear, informative wayfinding signage should be strategically placed at the station directly on the platform and station property, and at bus stops, to show multimodal connections and routes. Logos and colors between all transit agencies at connecting stations should be coordinated in the signage, and used as efficiently and succinctly as possible to avoid confusion.

Bus-Rail Connections

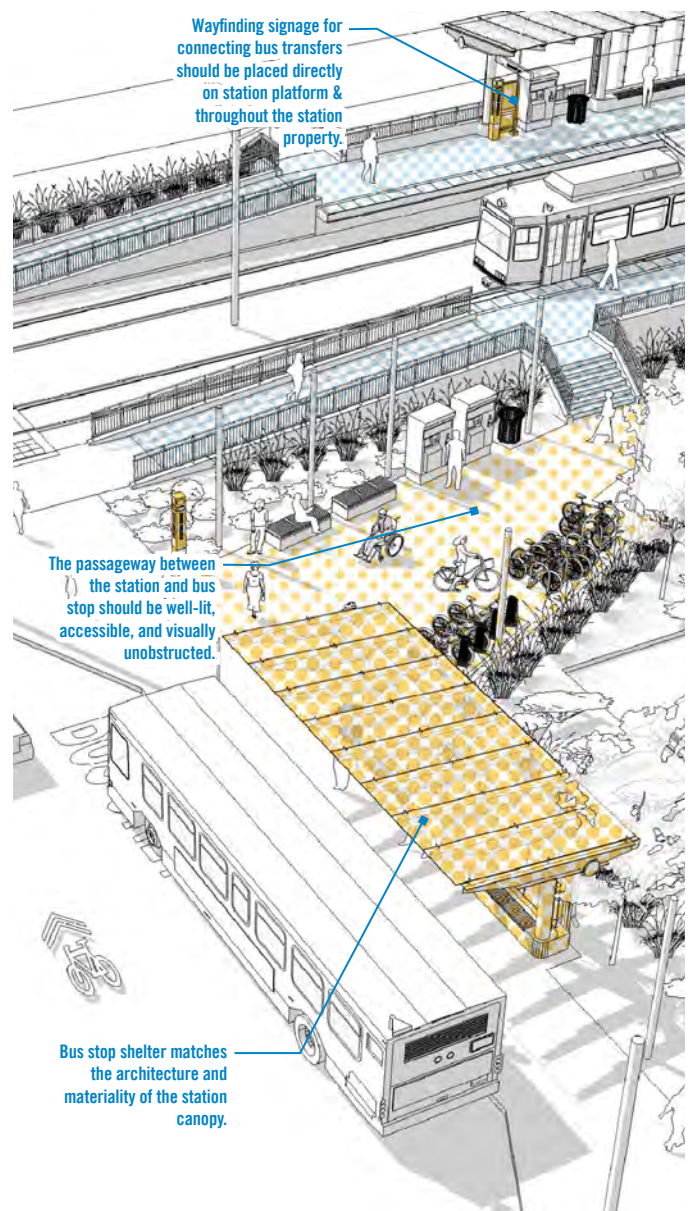

Incorporate agency logos and colors into wayfinding signage, which should be placed directly on station platforms and bus stop shelters. Culver City Station, Los Angeles

BICYCLE PARKING

Provisions to allow patrons to ride bikes to LRT stations can greatly increase ridership. According to the Association of Pedestrian and Bicycle Professionals, bike riders who are parking their bicycles for 2 hours or longer are considered “long-term” users and typically value security and shelter over convenience and ease of access. Accordingly, public transit applications would be considered “long-term” parking and should have specific characteristics to meet the needs of this type of user.

EXISTING

Types

There are several different types of bicycle parking “corrals” located at select LRT stations throughout the system. The corrals include inverted U, triangular, and serpentine shapes made from stainless steel, painted steel, and galvanized steel. The stainless steel and painted steel bicycle racks are in good condition. The galvanized steel bicycle racks are showing signs of rust where the galvanized coating shows signs of wear from use and salt.

Materials

The material used in fabrication varies among stainless steel, painted steel, and galvanized steel.

Challenges

Some of the challenges with bicycle parking include, finding an appropriate location and/or space for the parking, providing the appropriate level of security so patrons feel safe leaving their bikes, and selecting bicycle racks that will perform properly in the environment.

Opportunities

Varied types of bicycle parking can increase ridership by providing multimodal options for riders and by expanding the reach of the first-mile / last-mile transit opportunity.

REPAIR

The galvanized steel bicycle racks may be cleaned of rust and prepped for a cold galvanized touch-up, zinc-rich coating. The painted steel racks also should be cleaned of rust and prepped for touch-up paint.

REPLACE

Bicycle racks should be replaced when the integrity of the rack is unable to secure a bicycle, and/or the proposed repair is deemed to be unreasonable from an economic or aesthetic viewpoint. Refer to the “New” heading outlined below and the “Primary Materials: Metals” in Section 3.2 of these LRT Station Design Guidelines for recommendations.

NEW

Direct, safe, and easy access to the station entrance is expected. Stations should have sufficient bicycle parking available at all

times. Secure, sheltered parking should be provided where feasible to promote confidence that bikes will not be exposed to rain, vandalism, or theft.

Type

The type of bicycle rack recommended for outdoor use is the post and loop, such as an “A” Shape and Inverted “U” shape frames. These types of racks allow the user to lock a bike frame and one of the wheels with a standard U-Lock. A bike locker is another alternative. This aligns with the current standards implemented by the Pittsburgh Department of City Planning.

Location

Locations of bicycle parking areas will vary as the stations vary, but generally the convenience offered by weather protection and additional security is the highest priority. Bicycle parking should be located as close to station entrances as possible, visible to patrons but with limited exposure to public space. If the location is not highly visible upon approach to the station, directional signage may be necessary. A designated location for bicycle storage should be easily identifiable and integrated into the station design. Bicycle parking should be covered for protection from the weather by a canopy or placed in a location that provides some shelter. The bicycle parking area should be well-lit and located close to areas of increased pedestrian traffic where possible. The parking should be located far enough from obstacles such as walls, trees, etc. so the rack can be accessed and utilized from all sides (ie. a U rack should be able to have a bike locked to either side.)

Installation

The ideal installation surface for bicycle racks is a sturdy concrete pad; asphalt, pavers, and soft surfaces are much less desirable. The concrete pad will allow for adequate anchoring of appropriate fasteners including concrete spikes, wedge anchors, and security nuts.

Performance

The performance criteria for bicycle parking racks shall include supporting bikes upright, accommodating a variety of bicycle styles and attachments, allowing for locking of frame and one wheel, providing security and longevity, and being intuitive to the users. Racks that include a top rail are less desirable, as they limit the types of bicycles and attachments that can be accommodated.

Quantity

The required number of bicycle parking spaces will vary by station. Some stations are not accessible via bicycle, and therefore would not warrant bicycle parking. However, stations that are accessible by bicycle should have a minimum of 12 spaces. Additional parking may be necessary, in consideration of factors such as current and future bicycle use, ease of access to the station via bicycle, and types of patrons frequently using specific stations.



Utilize a mix of long- & short-term bicycle parking options, especially at suburban stations for downtown workforce commuters. McLean Station, Washington DC



For short-term parking, consider covered, structured exterior bicycle parking to increase capacity with limited space. North Berkeley Station, Berkeley



Couple vehicular & bicycle parking at parking facilities to encourage multi-modal ridership. Bus-Then-Bike shelter at Table Mesa Station, Boulder

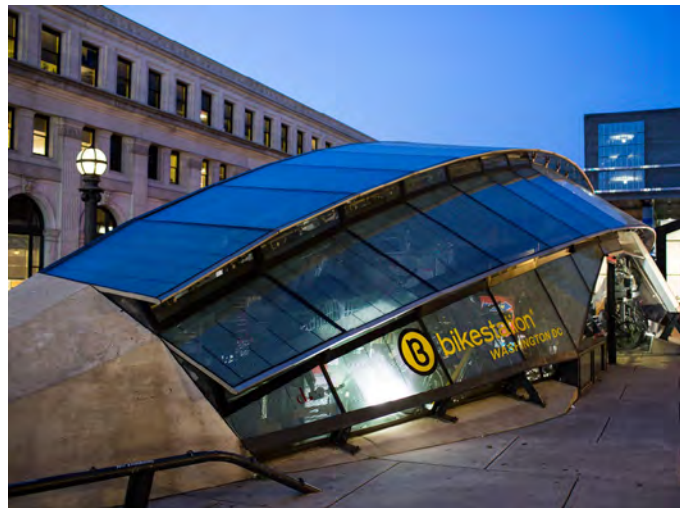

Partner with local organizations or small businesses to steward multi-modal facilities. Bikestation Parking and Changing Facility at Union Station, Washington DC

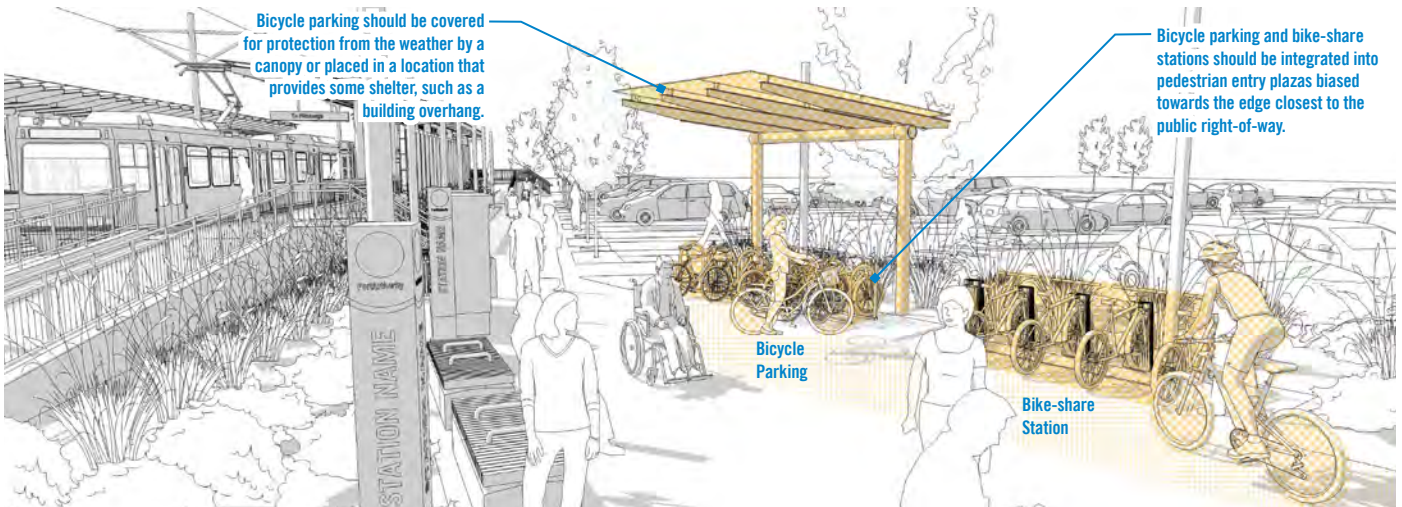

BIKE-SHARE STATION

Bike-share stations provide a convenient location for LRT patrons to obtain a bicycle for rent at a minimal fee, helping to conquer the first-mile / last-mile transit issue. Pittsburgh Bike Share, the non-profit company which owns and operates Pittsburgh's system, should be contacted and coordinated with for any decisions regarding the maintenance or placement of their stations. Properly placed, a bike-share station can promote ridership and potential sponsorship from advertisers.

EXISTING

Types

Several types of bike-share stations exist. Although they vary in shape size and configuration, they are very similar in function. They usually have a single pay-station kiosk and racking system to store the bikes. Stations are placed either in the public right-of-way (such as on sidewalks or plazas), or in the street against a curb (such as a vehicular parking stall).

Material

The bike-share stations are metal (usually aluminum or stainless steel or a combination of both); this allows the stations to be placed outdoors uncovered.

Challenges

The challenges are determining where to locate the bike-share stations throughout the system, where to place the bike-share stations at some LRT stations, and the correct number of bikes to provide.

Opportunities

If optimally located and well maintained, a bike-share station can promote multimodal connections, advance first-mile and last-mile goals, and provide advertising real estate.

REPAIR

Bike-share stations are owned and operated by outside vendors, so maintenance and repair would not be the responsibility of PAAC.

REPLACE

Bike-share stations are owned and operated by outside vendors, so maintenance and repair would not be the responsibility of PAAC.

NEW

Installation and placement should be coordinated with the bike-share operator and owner.

Location

LRT stations that are good candidates for a bike-share station are those that have either one or all of the following characteristics:

- Located in a dense, walkable area.
- Connected to a network of bike-share stations within a reasonable and bikeable distance.
- Situated adjacent to bike infrastructure, such as a bike lane or river trail.
- Surrounded by a large LRT station property such as an entry plaza or a wide sidewalk directly outside of the main entrance.

Placement of bike-share stations will vary as the LRT stations vary, but they generally should be located with easy pedestrian access and high visibility that does not require directional signage. Bike-share stations should be placed as close to the platform or LRT station entryways as possible for ease of access. Requiring patrons to cross through intersections or across streets to access a bike-share station should be avoided. Entry into the bicycling network, such as a bike lane or bike route, should be easily and safely accessible. The surrounding area would ideally have a high volume of pedestrian traffic to promote use and security. Placement of on-street curb bike-share stations with adjacent pull-off bus stops or passenger drop-off areas should be coordinated.

The infrastructure needs of the bike-share station when designing the placement. Some stations require solar power or wireless cell access.

Security

Proper security will enhance comfort levels for users. Public safety should include well-lit access points and overall site lighting near the bike-share station. The station should be integrated within the camera surveillance perimeter where feasible. If the bike-share station is located adjacent to vehicular traffic, wheel stops, bollards, planters, etc. should be incorporated to protect the station and its patrons, and should provide clear separation between types of traffic flow.

Installation

Since many of the LRT stations are unique, the bike-share stations may be arranged to fit varying site conditions. For example, the parking arrangement of bicycles may be oriented at an angle to accommodate a narrow site, or back-to-back for a wider area that is not as long. Bike-share stations should be located on a concrete pad to promote safety, security, and easy access, while minimizing potential maintenance of the area through continued use.



For stations with limited site property, consider placing bike-share stations along vehicular curb parking, with visible markings and bollards. HealthyRide bike-share station on Third Ave., Downtown Pittsburgh.

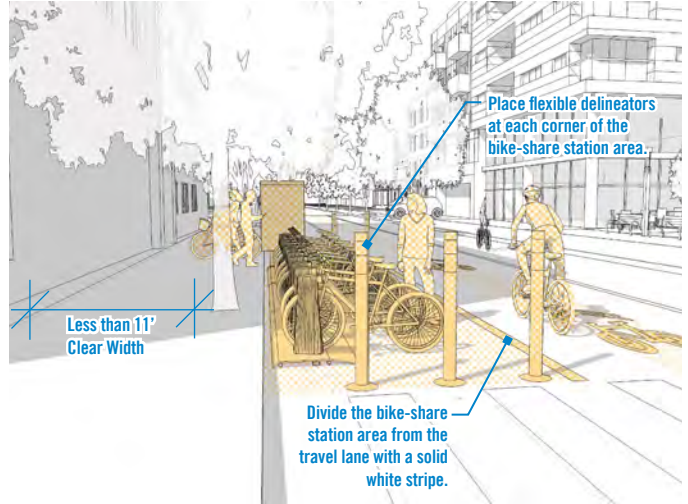

On-street placement is preferred where sidewalk widths are less than 11' and on-street parking is present.



Consider each bike-share system's installation needs, such as solar power or required installation clearances. Biketown bike-share station at Convention Center MAX Station, Portland

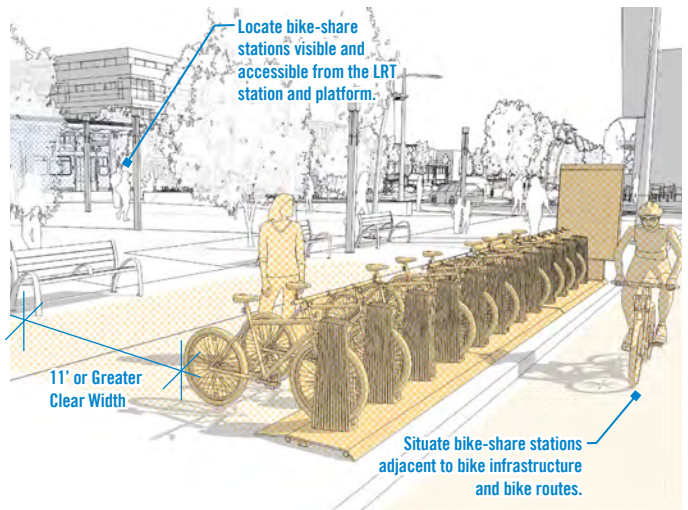

Sidewalk (curb-adjacent) placement is preferred where sidewalk widths are 11' or greater and on-street parking is not present.



Place bike-share stations visible to platform entries, and adjacent to the public street or bike lanes. Capital Bike-share station at Virginia Square-GMU Station, Arlington

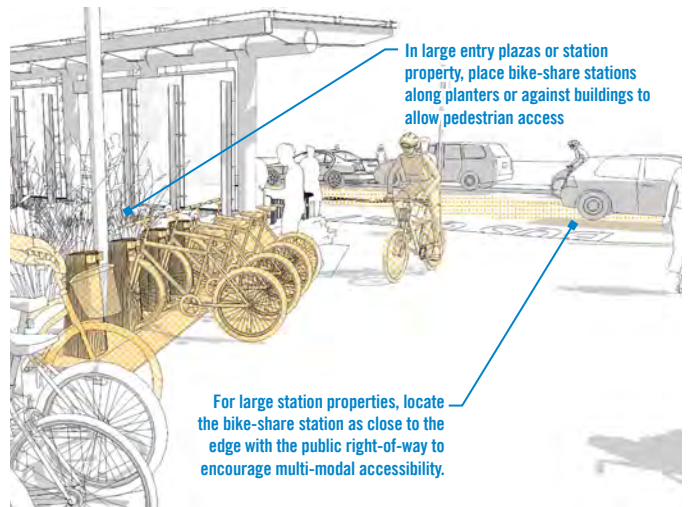

Sidewalk (building-adjacent or entry plaza) placement is preferred where sidewalk widths are 11' or greater and on-street parking and transit stops are present.

PASSENGER DROP-OFF AREA

Provisions to allow passenger drop-off areas at LRT stations can be an efficient, low-cost way to increase ridership by allowing vehicle access without the need for long-term parking. These areas allow high volumes of patrons to access the stations in a relatively short period of time. However, additional curb space, which is not available at every station, is necessary to accommodate drop-off / pick-up patrons. Typically, the afternoon pick-up will require longer wait times than morning drop-off. Therefore, it is important to provide adequate space for vehicles to wait an average 6 to 8 minutes, particularly in the afternoon. Wait lines must not disrupt traffic flow of other vehicles entering and exiting adjacent parking lots and access roads, including other mass transit vehicles where applicable.

EXISTING

Types

There are several passenger drop-off areas located at specific LRT stations throughout the system. The areas include concrete curbs that extend parallel to the drive aisles to allow vehicles to quickly pull in and out of the stalls.

Materials

The passenger drop-off areas usually consist of asphalt paved drive aisles with concrete curbs and sidewalks.

Challenges

The challenges facing most passenger drop-off areas deal with climate, maintenance, and limited space. The temperature changes and salt utilized to prevent slips deteriorate the materials, which requires regular maintenance. The drop-off areas require additional curb space, which is not always available.

Opportunities

The passenger drop-off areas could increase ridership by providing riders an option to be dropped off without the hassle of long-term parking or the fear of holding up traffic. The passenger drop-off curb pull-off also allows vehicular traffic around stations to run more smoothly, as less vehicles are parking in the carriage-way to let passengers off.

REPAIR

Refer to “Primary Materials: Concrete” in Section 3.2 of these LRT Station Design Guidelines.

REPLACE

Refer to “Primary Materials: Concrete” in Section 3.2 of these LRT Station Design Guidelines.

NEW

Location

The passenger drop-off areas should consider convenience and safety of all patrons. These areas should be located close to the station platform and oriented such that drivers waiting for pick-up may view the LRT station pedestrian exit. The location of the waiting area should consider the fact that passengers will most likely enter and exit the vehicles from the passenger's side. This may dictate crosswalks be incorporated into the design. The drop-off locations should be designed to accommodate bus and paratransit vehicles as part of the multimodal system. This may dictate a separate drop-off from the passenger vehicles and a larger pull-off areas to accommodate the larger vehicles.

Depending on the location of the platform to the main public street, passenger drop-off areas can be incorporated along streets as simple pull-in facilities or as loop roads for stations that are interior from the main vehicular street or have a parking lot associated with them. City or municipality officials should be involved in coordination when introducing off-site curb cuts, pull-ins, and signage.

Additionally, drop-off areas can be buffered from access roads or parking areas with landscaped planting areas or bollards. Covered canopy or shade trees can be provided adjacent to the drop-off area to provide shade and weather protection for passengers waiting for pick-up.

Signage

The drop-off areas should be clearly marked and have appropriate signage that provides a sense of place and direction. The signage should match the other station-related signage aesthetic and address both vehicles and passengers. The area should be sized to meet demand, and consideration should be given to increased need during periods of inclement weather. All provisions must meet current ADAAG requirements.

Quantity

The required number of short-term passenger drop-off stalls will vary by station. Some stations are not accessible by vehicle, and therefore would not warrant stalls. However, stations that are accessible by vehicle should have a minimum of three stalls. Additional stalls may be necessary for drop-off / pick-up, in consideration of factors such as current and future use, ease of vehicle access to the station, and types of patrons frequently using specific stations.

Passenger vehicle stalls should be slightly larger than a typical parking stall due to frequent turnover and fluidity of need and use. As such, parking stalls shall be 10 feet wide and 20 feet long.

Passenger Drop-Off & Multimodal Connections

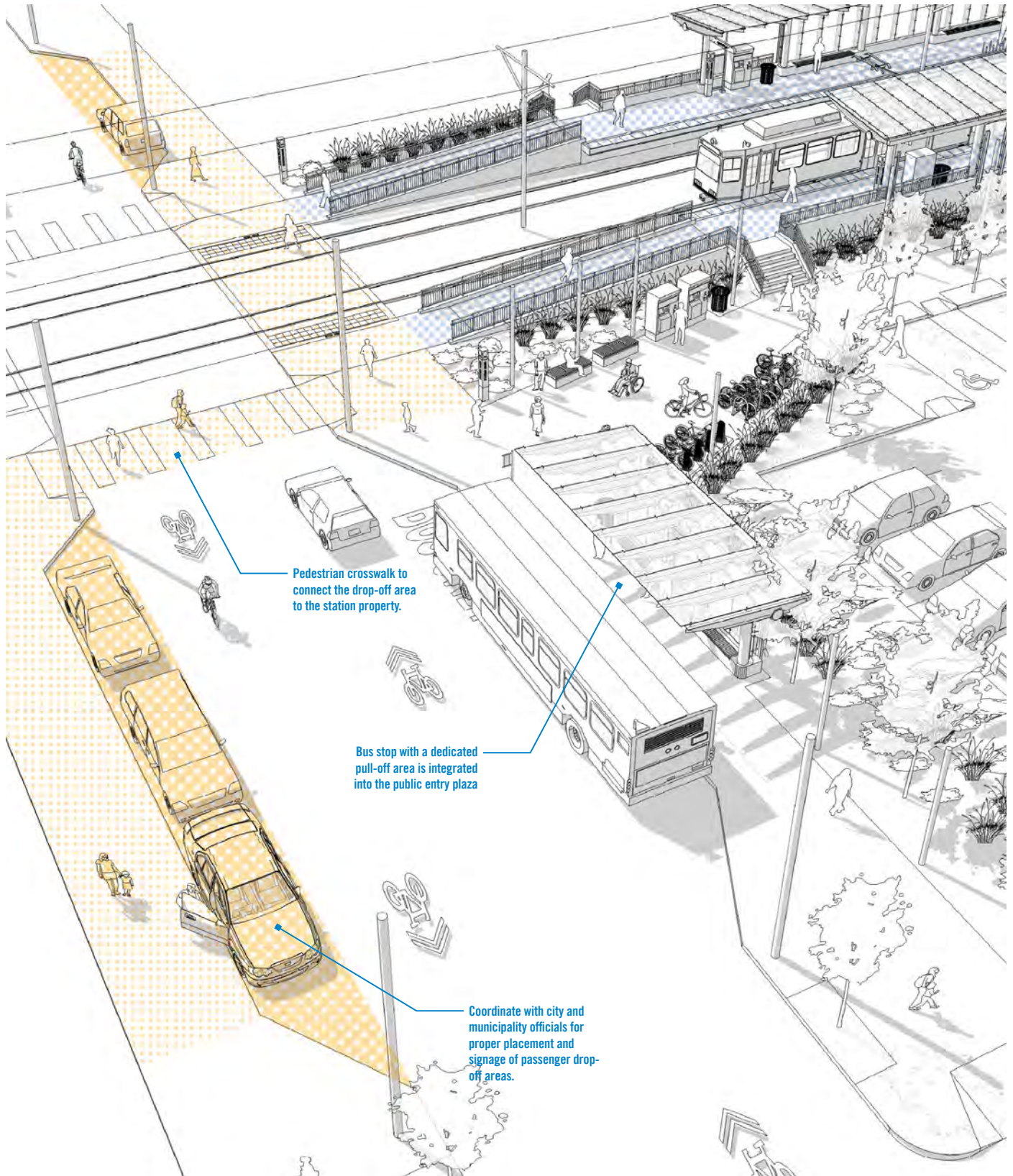

RETAIL KIOSK

The retail kiosk provides a level of convenience and service that many commuters come to expect, and it makes the transit experience more enjoyable. This convenience benefits the PAAC brand, which increases ridership. Many retailers are viewing transit systems as attractive locations for small-size but high-volume kiosks. Since transit riders typically have short wait times, the retail kiosk offers opportunity for buy-and-go sales such as magazines, coffee, packaged food and selective services.

NEW

Location and Orientation

The retail kiosk is most desirably located near a plaza or larger walkway area where pedestrians are moving through, and there is adequate space for a kiosk. Consideration should be given to the sufficient supply and service of water, power, and trash and recycling receptacles for the kiosks, as well as future renovations and enlargement of stations. This particularly important where there are parking lots/garages, other modes of transportation, and TOD opportunities.

Retail kiosks should be located off of the main path-of-travel to the rail platform, with their front storefronts facing the open space. If multiple kiosks are provided at a station, the kiosks should be spaced out to provide comfortable breathing room for pedestrians to walk between. To successfully activate the open space around the kiosks, vendors should be encouraged to provide seating and tables for patrons. Additional site lighting, trash receptacles, and planting should be provided to make this space comfortable, safe, and activated.



Retail kiosks create economic opportunity and contribute to lively public entry plaza at the entrance to Schenley Plaza, Pittsburgh.



Retail kiosks provide on-the-go fare, economic activity, and a central node which adds to rider safety at the Fashion Valley Transit Center, San Diego.

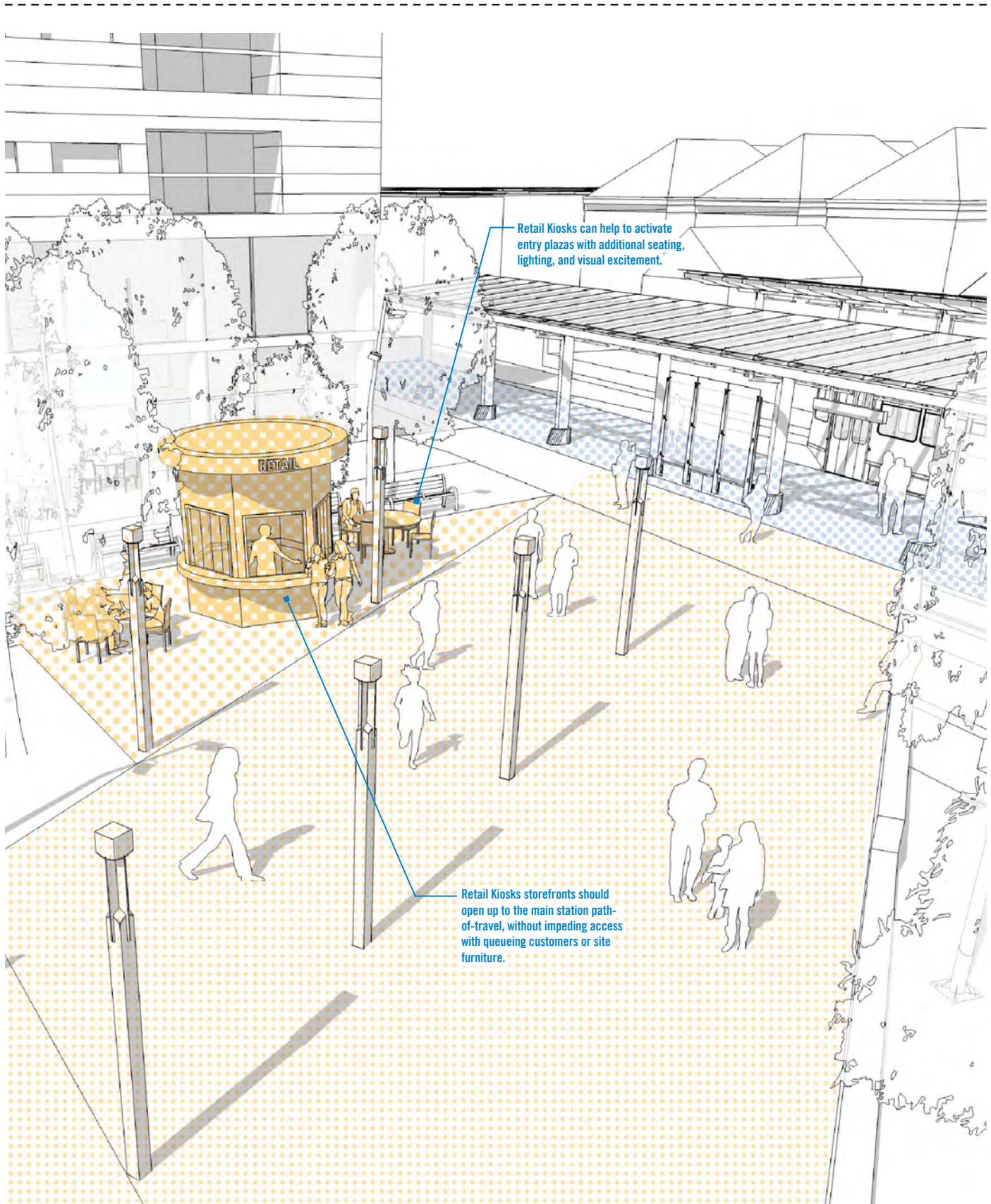

COMMUTER PARKING CONNECTION

Multiple stations within the PAAC LRT system have a commuter parking lot connected to or associated with the station. The connection between the station platform and the parking lot lies on the station property, and should be designed to best provide a safe, accessible, and direct connection for pedestrians going between the two areas.

EXISTING

Stations with parking areas are referred to as park-and-ride. The park-and-ride connections are usually surface parking lots, but the South Hills Village station and First Ave. Station are associated with an adjacent multi-level parking structure.

The surface lots are typically comprised of asphalt paving with concrete walks for pedestrian safety. The structured parking is precast concrete double tees with a precast structure and shell.

REPAIR

As with any walkway or ramp infrastructure at stations, repair of concrete and metals shall follow guidelines. Refer to “Primary Materials: Concrete” and “Primary Materials: Metals” in Section 3.2 of these LRT Station Design Guidelines.

NEW

As with any new walkway at stations, the commuter parking connection should be as direct and accessible to the platform as possible, giving riders a clear and non-confusing path of travel and direction between the two areas.

Configuration

The parking lot connection, while being a basic pedestrian walkway, should be designed to be aesthetically pleasing and inviting. This pedestrian walkway shall avoid being circuitous or weave in between vehicle parking stalls.

For stations with ample space, this connection should lead to a public entry plaza, where riders can access information and ticket kiosks conveniently. This connection zone also provides opportunities for planting and public art lining walkways or placed in guardrail infrastructure.

Pedestrian Safety

The main design consideration for the commuter parking connection should be how to safely connect pedestrians between the parking lot to the station.

Particular attention shall be provided for pedestrian connections through the implementation of enhanced crosswalks, curb cuts, and pedestrian-scaled lighting. A grade separated sidewalk is ideal to separate pedestrians from vehicular traffic, while also providing a visual direct walkway to the station entrance. Additionally, this walkway could be covered, providing extra protection for pedestrians during all seasons and weather conditions.

Signage is crucial to the success and safety of commuter parking connections. Pedestrian-scaled wayfinding signage directing riders how to navigate safely through the vehicle parking lot to the platform shall be provided. Additionally, driver-oriented signage at crucial pedestrian-driver conflict zones, such as at crosswalks shall be provided.

If commuter parking is located across an intersection or not directly touching a station, additional elements and infrastructure should be considered. Pedestrian safety considerations, such as crosswalks, signage, sidewalks, and accessible curb cuts should be designed into this connection between the parking lot and the station platform. For parking lots or parking structures at particularly hilly or topographically challenging stations, pedestrian bridges should be considered to provide the best direct and safe connection to the platform.



A covered walkway leads riders between the parking structure and the station platform at the Angle Lake Station, Seattle.



For high-investment, high-volume stations with parking structures, consider connections which reduce pedestrian safety issues. Parking garage and platform connection at Baldwin Park Station, Los Angeles

Occasionally, the commuter parking lot lies between the public right-of-way or street and the platform, creating a difficult and dangerous connection for pedestrians walking between the public sidewalk, through the parking lot, and the station. Consideration should be taken to accommodate pedestrian traffic traversing through the vehicular parking to access the station. Elements such as raised median walkways and pedestrian signage should be provided for pedestrian access to platforms.



Investment into pedestrian safety infrastructure, such as enhanced crosswalk, signage, and curb cuts, are required at stations with parking lots. Sidewalk and platform connection through parking lot at Washington Junction Station, Pittsburgh

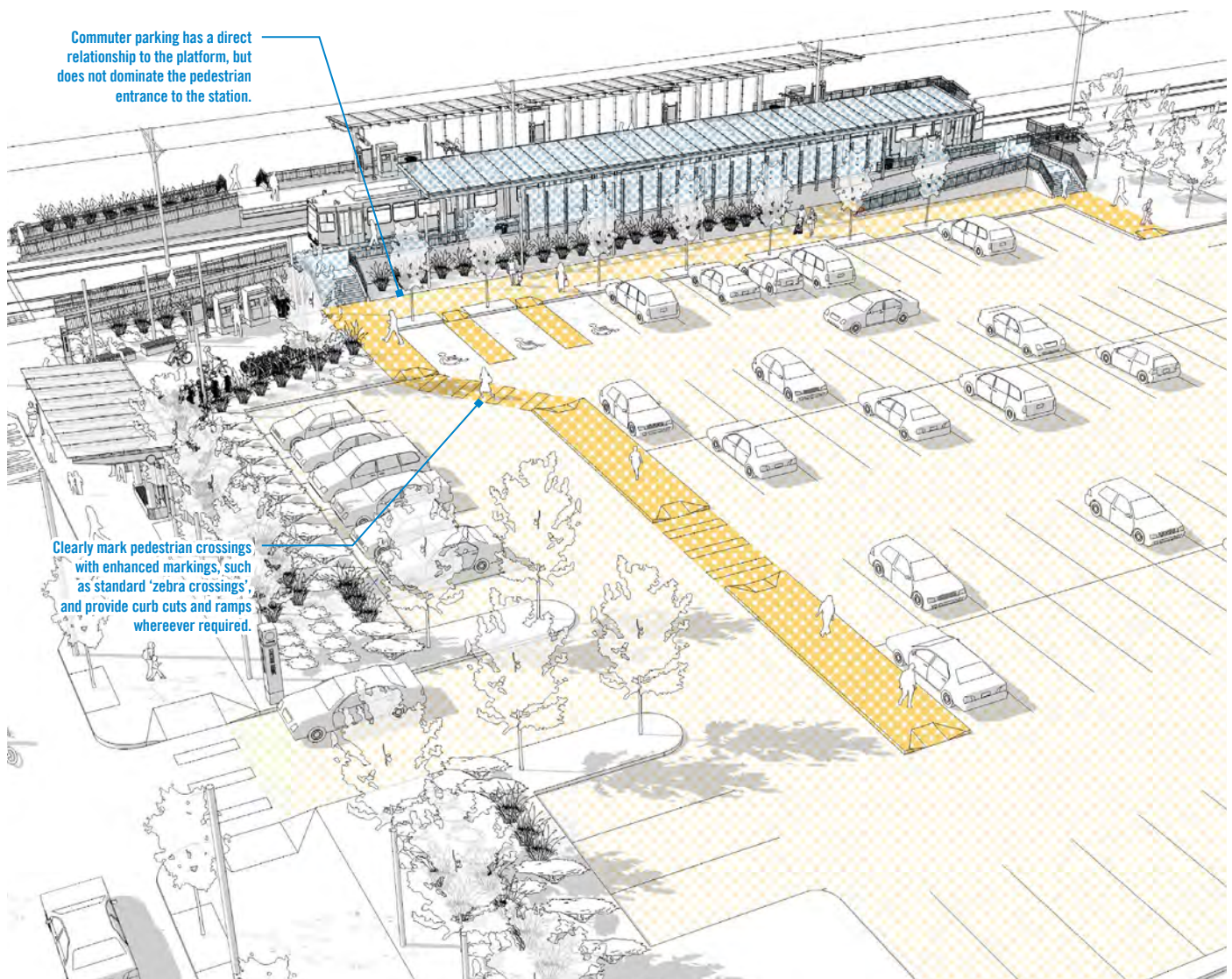

PLATFORM AMENITIES

Overview

Platform amenities help to increase rider comfort, and make using the system easier. Existing amenities are varied and applied differently among stations. New amenity guidelines should strive to bring visual consistency and usefulness to these platform components, with the rider at the heart of all decision-making. Unlike common platform elements found across all stations, platform amenities should be considered at various stations according to station type and allowable space.

Platform Amenities Elements

- Seating
- Leaning Bars
- Platform Lighting
- Windscreens
- Trash & Recycling Receptacles
- Advertising
- Public Art



Sidewalk platform at PSU Urban Center / SW 6th & Montgomery Station, Portland



Parallel traffic, median platform at Snelling Ave. Station, Minneapolis / St. Paul



Central, traffic separated platform at Union Station, Los Angeles

Platform Amenities

- A** Seating
- B** Platform Lighting
- C** Windscreens
- D** Trash & Recycling Receptacles
- E** Advertising

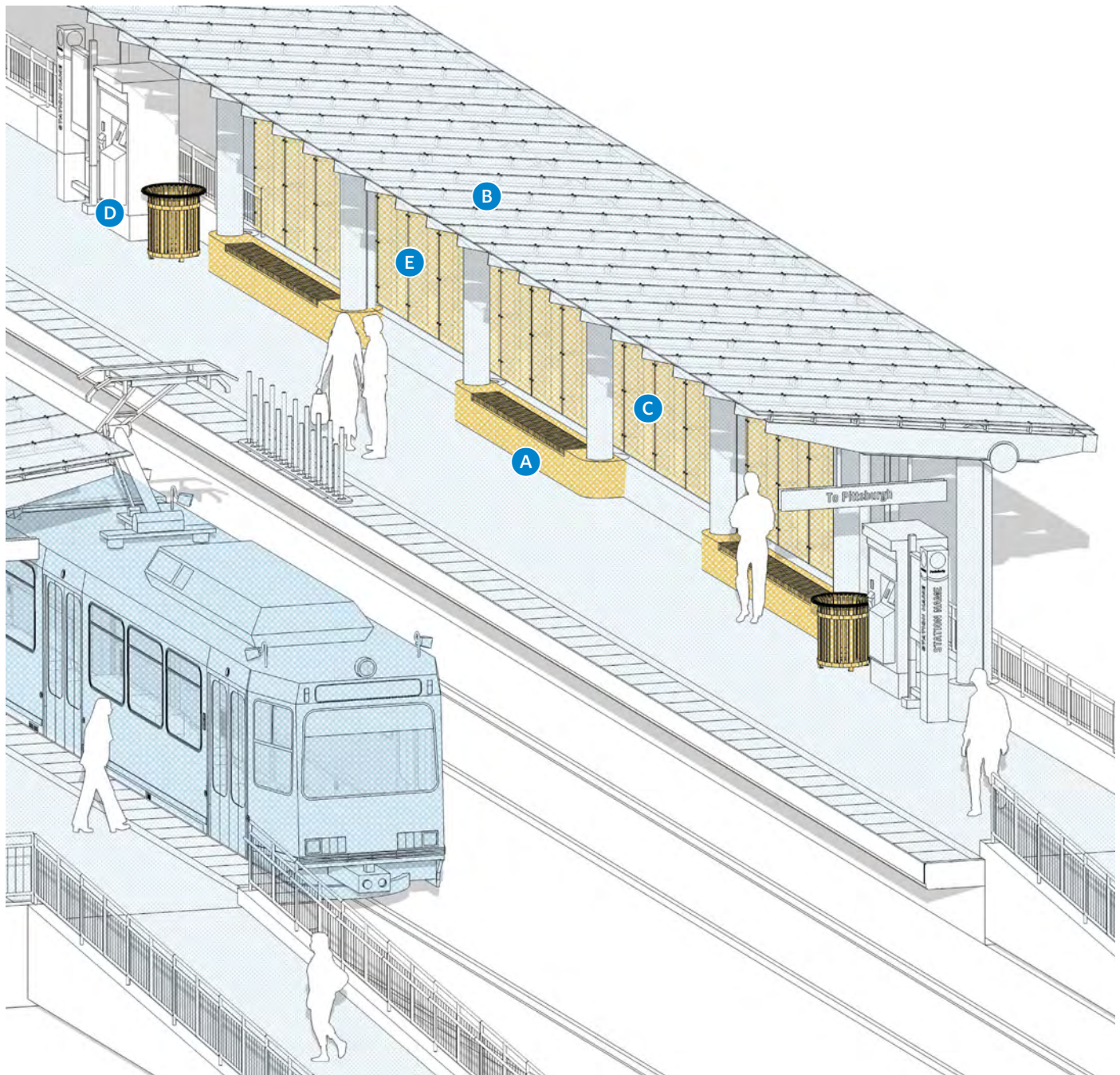

SEATING

Seating is an opportunity to incorporate an attractive and comfortable experience for the waiting passenger and should be designed with both comfort and durability in mind. This portion of the guideline is focused on seating at the platform level or within the vehicle boarding area and not within the greater site area of a station. It is recommended at each platform to provide seating under a protective canopy to provide patron comfort and protection from sun, rain, snow, and wind. The decision where and how much seating to place at stations depends on the following factors: space availability, ridership, and cost. Some platforms cannot accommodate seating due to size and space limitations, and other platforms do not warrant the investment of seating due to low ridership. The minimum clearance recommended from the face of the bench to the warning stripe is 8'-0". If this cannot be accommodated, it is not recommended to provide a bench. In these situations, a leaning bar may be appropriate. Another scenario that would favor utilizing a leaning bar in lieu of seating is when the ridership at a station is below 100 patrons/day. This scenario would not warrant the investment and associated cost of seating.

EXISTING

Types

The existing seating throughout the system is of varying materials, types and placement.

Materials

The materials utilized include wood tops with aluminum support posts, granite top and face on concrete block substructure, painted metal, and painted precast concrete. Most seating and benches are placed under a protective canopy, but there are a few locations where seating is open to the elements.

Challenges

The challenges with seating are providing an adequate amount of seating for the patrons, providing seating that is durable for the harsh environment, providing seating that will not be damaged and/or stolen, providing seating that contextually appropriate, and limiting the different types of seating for ease of maintenance or replacement.

Opportunities

As the various types of seating within the system are replaced, opportunities exist to create a prototypical design that would solve most, if not all, of the challenges listed above. For instance, the East Liberty Station along the Busway has been redesigned to include concrete benches with very durable wood seats. The benches are integrated into the canopy structure and both are designed to allow for expansion, if necessary.

REPAIR

The seating benches are subject to deterioration over time due to weather exposure, salt, sun, and precipitation. Where seating is not part of larger station improvement or replacement project, the repair of existing seating is necessary when it becomes unsafe for the public or unsightly.

For wood top benches, designers should consider composite wood or plastic product repairs that provide the same warmth as wood but with a greater life span. Repainting of steel and concrete benches should utilize the appropriate surface preparation and paint specifications, as described in the General Materials section of this document.

REPLACE

For consistency, any seating that needs to be replaced shall be the same as defined under the "NEW" section.

NEW

Intermediate rails between each seat will discourage sleeping while still providing the maximum length of seating that can be accommodated at each station. Passenger seating (with a minimum of 12 LF per platform) shall be distributed to two or more locations. All seating must be arranged so as not to interfere with patron circulation and/or emergency exiting. At least 75% of seating shall be protected from the rain. The bench should be designed in 2-foot increments, with a minimum bench length of 6 feet, and ideally located in at least two places on the platform. The location of seating should not impede customer access to station elements, and a wheelchair area is required adjacent to at least one bench of size and configuration per ADAAG requirements. Benches should be designed to prevent the accumulation of water and trash, and should utilize warm materials like wood or composite materials that can easily be replaced over time. The concrete base on this bench will withstand the heavy use of salt during the winter months and be easy to maintain during platform power-washing.

Refer to the Appendix for design details.

New Integrated Seating

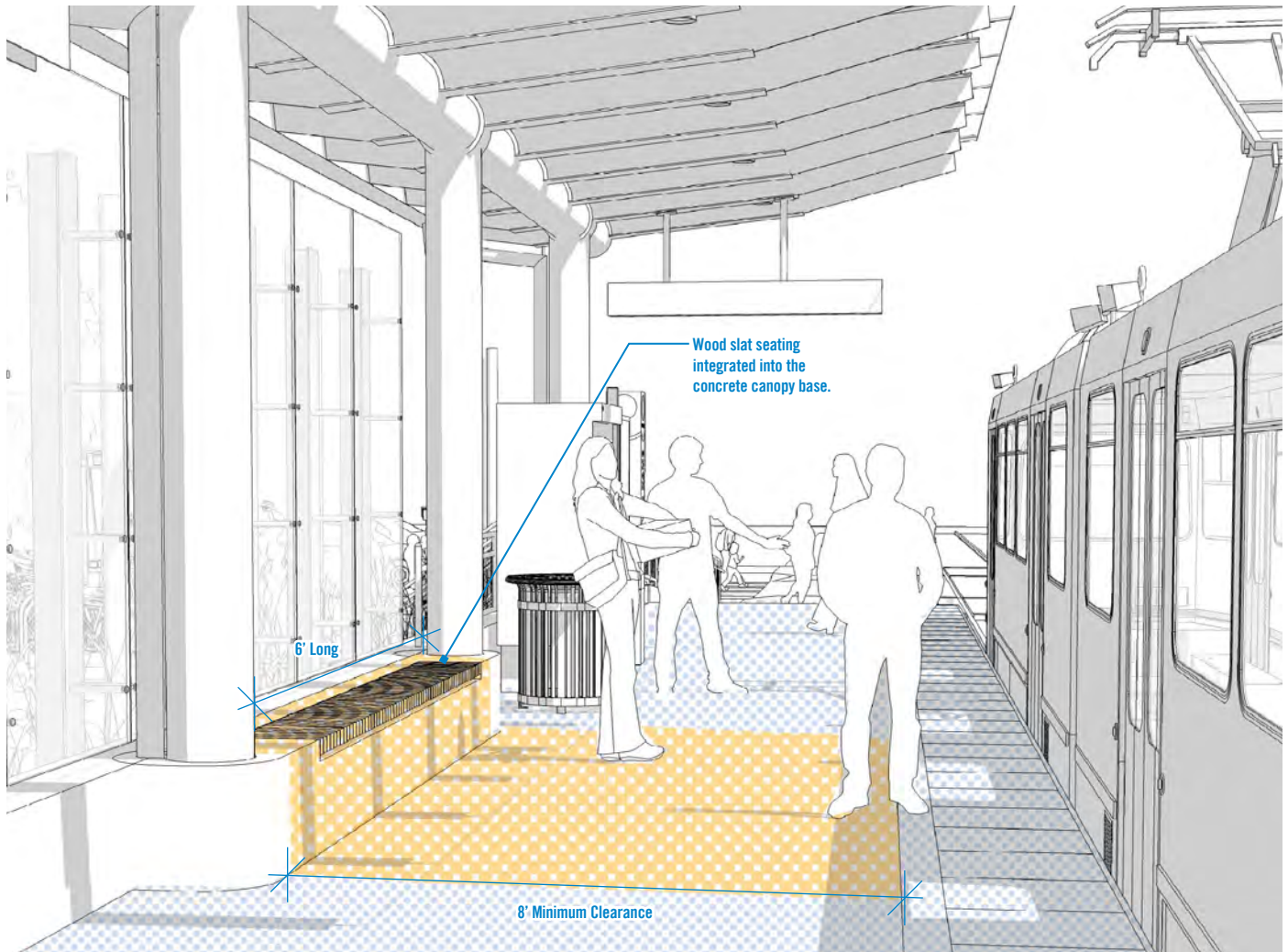

Seating Placement

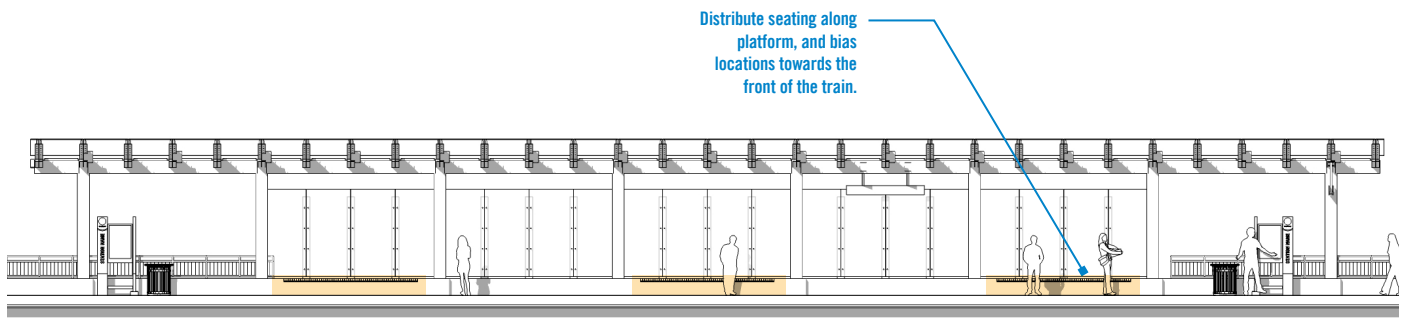

LEANING BARS

Leaning bars or rails afford patrons a level of comfort when incorporated at a station where there is little to no seating, and where the station width is limited (between 4 to 8 feet of clear width), which is predominantly the at-grade stations.

EXISTING

Types

The existing light rail system does not utilize a leaning bar product, but does have guardrails that are utilized as a leaning rail, some with a larger top rail to provide a more comfortable leaning surface.

The only precedent within the system that can be referenced are leaning bars at the Smithfield Street bus station in downtown and Neville ramp at Centre Avenue, both produced by the same manufacturer. The design for the leaning bar at Smithfield Street is a simple, powder coated, tube steel vertical support with the same diameter horizontal tube. The design at the Neville ramp is a flat, perforated metal leaning bar, surface-mounted directly into the concrete canopy base behind it.

Material

Leaning rails are made of metal, usually painted steel, aluminum, or stainless steel.

Challenges

The challenges that are faced with regard to leaning bars are location of the bars, quantity, and protection from salts during the winter months. It is preferred to provide weather protection at the leaning bars, but it is not cost-effective and may not fit within the space available.

Opportunities

Leaning bars can more economically provide a place for patrons to rest and the ability to provide more leaning area than possible seating. Providing stainless steel leaning bars is another potential opportunity that will allow for lower maintenance over time.

REPAIR

The repair of these rails is mainly repainting them, and should follow the Painting section of these guidelines for surface preparation and paint selection.

REPLACE

When leaning bars are to be replaced, the new bars should follow the new leaning bar detail and materials.

NEW

The horizontal rail should be 30 to 38 inches above grade and allow passengers to rest while waiting. The leaning bar can be used to channelize pedestrian movements to and from boarding platforms when placed at the back of the boarding area.

Much like seating, leaning bars should be placed under canopy coverings for weather and sun protection whenever possible. Lighting should also accompany the placement of the leaning bars for security and safety.

Leaning bars should not be mounted directly into the ground to avoid rust or salt damage. Leaning bars should be surface-mounted into the concrete base of canopy structure, the canopy structure itself if there is no concrete base, or into a backing guardrail or structure if no canopy is present. Leaning bars at a station that does not have any viable structure to surface mount into may be mounted into the ground with vertical supports, although more maintenance will be required due to water and salt damage.

Aesthetically, a leaning bar product that best matches the canopy structure or other station platform elements should be selected. Considerations should be made for the color, material, and finish of the leaning bar product.



Along narrow platforms or high-volume stations, provide freestanding leaning bars in place of benches to save space. Nostrand Ave. bus stop, New York City

New Leaning Bars

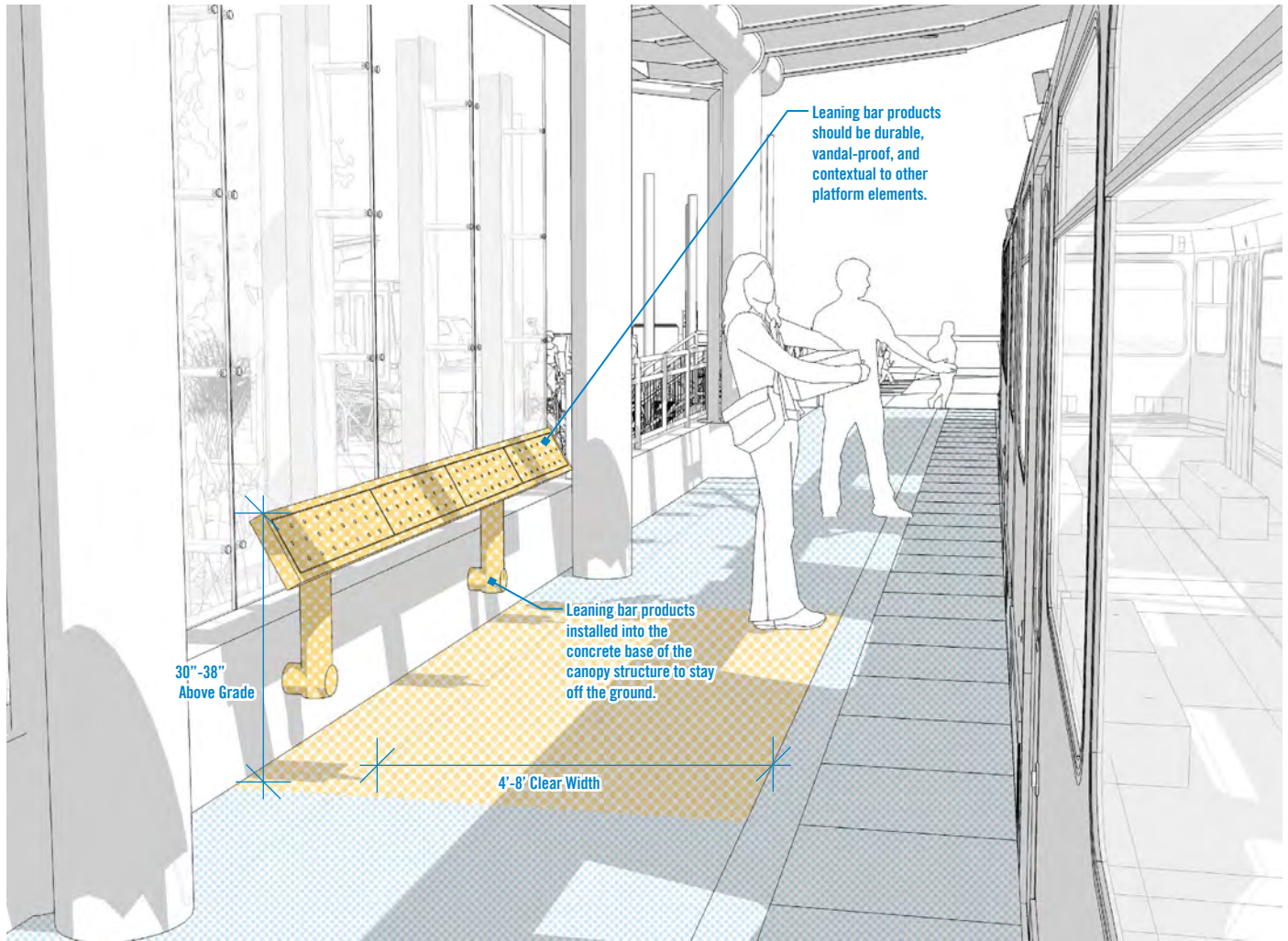

Covered leaning bar product along narrow boarding platforms should be mounted directly to the canopy structure. Neville Ramp Station, Pittsburgh



Similar to benches, cover leaning bars wherever shelters or canopies are present. Snelling Ave. Station, St. Paul

PLATFORM LIGHTING

Lighting is a critical component for the LRT platform. The lighting provides visibility at night, provides a level of safety and security for the patrons, and can provide character to the station design.

EXISTING

Types

Existing platform lighting varies greatly between stations ranging from under canopy, canopy support-mounted, and indirect sconce. The lighting is both direct (facing downward toward the surface to be lit) and indirect (facing upward and reflecting off another surface to light the desired space). The direct light fixtures are the most common, since they are the most efficient way to light a surface. The indirect fixtures are less efficient but can provide less glare and a different aesthetic/atmosphere. At some stations there are pole-mounted fixtures with bases that are either mounted to the platform or mounted to concrete piers on the platform. The numerous different fixtures associated with each line have resulted in not only inconsistent appearance and performance but difficulty in maintaining and supplying the variety of lamp types.

Material

The light fixtures and light poles within the system are constructed of metal (painted steel or aluminum) and have lenses constructed of glass or polycarbonate.

Challenges

The existing challenges included managing and maintaining the various types of fixtures and lamps present in the system. Due to the age of many of the fixtures, the lamps are becoming antiquated and not easily replaced. The fixtures are not energy-efficient and do not provide the same foot-candle levels over time.

Opportunities

By replacing fixtures, PAAC can standardize the fixture types to reduce the maintenance costs. They also can improve energy efficiency and longevity of lamp life by utilizing LED fixtures. PAAC also has the opportunity to create a new aesthetic for lighting throughout the system that ties all the various stations together.

REPAIR

If the fixture is not beyond its useful life, the fixture and/or lamp should be repaired.

REPLACE

Replace lights by following the new guidelines listed below. It is recommended that if a fixture type is replaced/upgraded at a station, the remaining fixtures at that station be upgraded to match the new guidelines.

NEW

New or replacement lighting should take into consideration aspects of safety, security, and aesthetics. The first step in the lighting strategy involves following the code requirements and lighting standards for each area of the station.

Platform signage that is not internally illuminated should be directly illuminated. Illumination levels shall be selected to maximize station security during nighttime hours. Non-operating illumination shall be the level required to support CCTV surveillance and shall be coordinated with PAAC Police & Safety.

General principles for lighting include:

- Identify and properly illuminate areas and elements of potential hazard and/or any potential tripping hazards such as at entry to vertical circulation elements (steps or ramps). Promote safety at platform edges where crowding and rapid transfer to and from trains or vehicles can be anticipated.
- Enhance the system's visual and functional clarity by differentiating between site circulation walkways such as drop-off zones and parking areas, station entrances, stairways, fare vending areas, and station entry points. Adequate lighting is particularly important to visually impaired individuals, who frequently depend on public transit for transportation.
- The use of both direct and indirect fixtures should be considered for safety and aesthetic concerns. The location and spacing of the fixtures should always provide the appropriate foot-candle levels.
- Lighting should not cause glare to patrons and approaching transit vehicles. It should be noted that excessive glare can cause unsafe conditions by blinding patrons.
- Lighting fixtures should be vandal-resistant is space accessible to patrons.
- The lighting system shall be energy-efficient, using high-efficiency LED lamps designed to minimize life-cycle costs while taking into consideration capital costs as well.
- Lights shall be easily accessible for replacement of lamps and avoid hard to get to areas directly above a long run of stairs or steep slope.

Standards

- Illuminating Engineering Society Lighting Handbook www.iesna.org
- American with Disabilities Act
- Standard for Fixed Guideway Transit Systems (NFPA 130)
- Life Safety Code (NFPA 101)
- National Electrical Code (NFPA 70)



Station Area	Average Horizontal Foot-candle
Station Platform - Covered	10
Station Platform - Uncovered	10
Fare Vending	10
Pedestrian Ramps and Walkways	15
Stairs	15
Security Camera Areas	15

Platform Lighting Elements

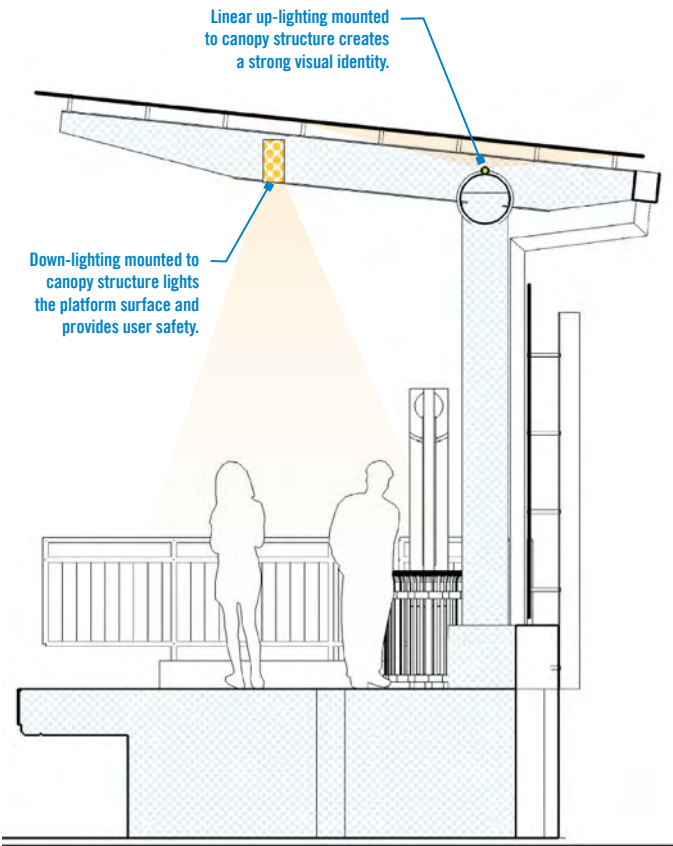

Platform Lighting Distribution

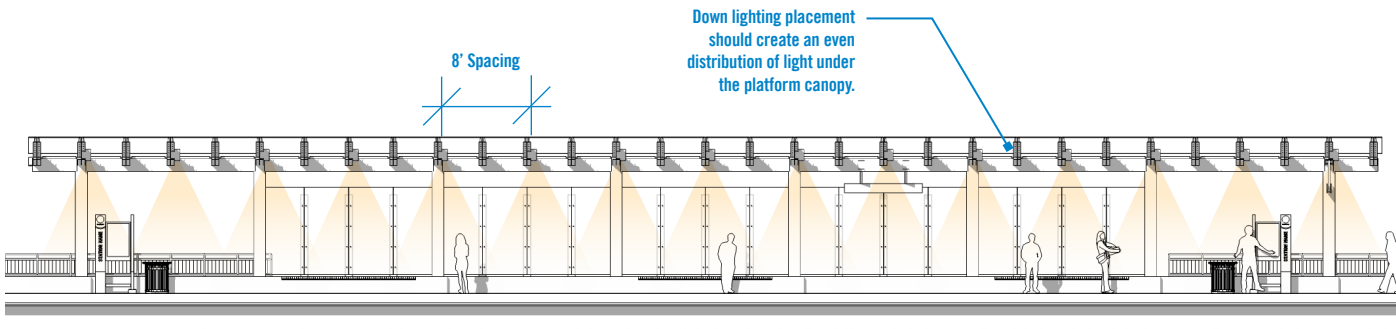

WINDSCREENS

The windscreen can serve to protect patrons from strong wind-blown rain and snow while serving to add an aesthetic and functional element to the station.

EXISTING

The Stage II stations have existing windscreens that provide protection to the platform, while some of the older street level stations have windscreens integrated into the back and side support walls. The older stations screens are similar to a prefabricated bus shelter type of system where the Stage II screens serve as an aesthetic element with contrasting color and arched mullions.

Types

There are several types of windscreens throughout the LRT system, including side and rear panels at premanufactured bus shelters at smaller platforms, as well as, integrated custom glazed storefront systems at seating areas.

Material

The materials utilized are aluminum, polycarbonate, and glass. Aluminum is used for the frames, structure, and infill panels; polycarbonate and glass are used as the transparent view panels.

Challenges

Due to the climate of Pittsburgh and heavy use of salt during the snowy winter months, some of the shelters are corroded and need to be repaired or replaced. Additionally, some of the wall panels are subject to vandalism, so upkeep and maintenance can be a concern.

Opportunities

Replacing damaged or failing windscreens with new screens that meet the proposed guidelines provides an opportunity to improve performance and reduce maintenance cost. Installing windscreens at stations where they don't exist provides opportunity to protect the users, as well as, an opportunity to standardize the station designs.

REPAIR

Windscreens shall be repaired as required to maintain protection and safety for the passengers. The replacement materials should match the existing materials and not be substituted.

REPLACE

Windscreens shall be replaced to meet the new requirements.

NEW

At locations adjacent to patrons, it is recommended to utilize laminated glazing. This will provide an easily maintained surface, that is graffiti-, scratch-, and vandal-resistant. To provide protection to patrons, each new station shall be provided with a modular

windscreen constructed of laminated glazing and supports between each vertical support column under a canopy cover. The modularity will provide ease of handling and replacement if damaged. If seating is provided, windscreens should be placed to protect the seating or lean bar areas. The transparent material is important to provide a level of security for the patrons. Screens shall be either supported by a concrete curb or raised up to allow power-washing and ease of cleaning below the screen. Refer to the detailed drawing of the windscreen at a platform.

Windscreens also provide the opportunity to integrate signage, advertisement, and public artwork into the glazing, which can provide extra shading, historical reference to station context, and bird deterrent. As with seating and other platform amenities, the decision to include windscreens at stations should be based on the constructability and the ridership. It is recommended that stations with more than 300 passenger/day include a windscreen.



Side, perpendicular screens can help provide more protection, along with integrated artwork that provides extra shading and context. Tom Hunter Station, Charlotte



Integrate windscreens and artist designed graphics to provide visual interest and translucency. Prospect Park Station, Minneapolis

New Integrated Windscreen

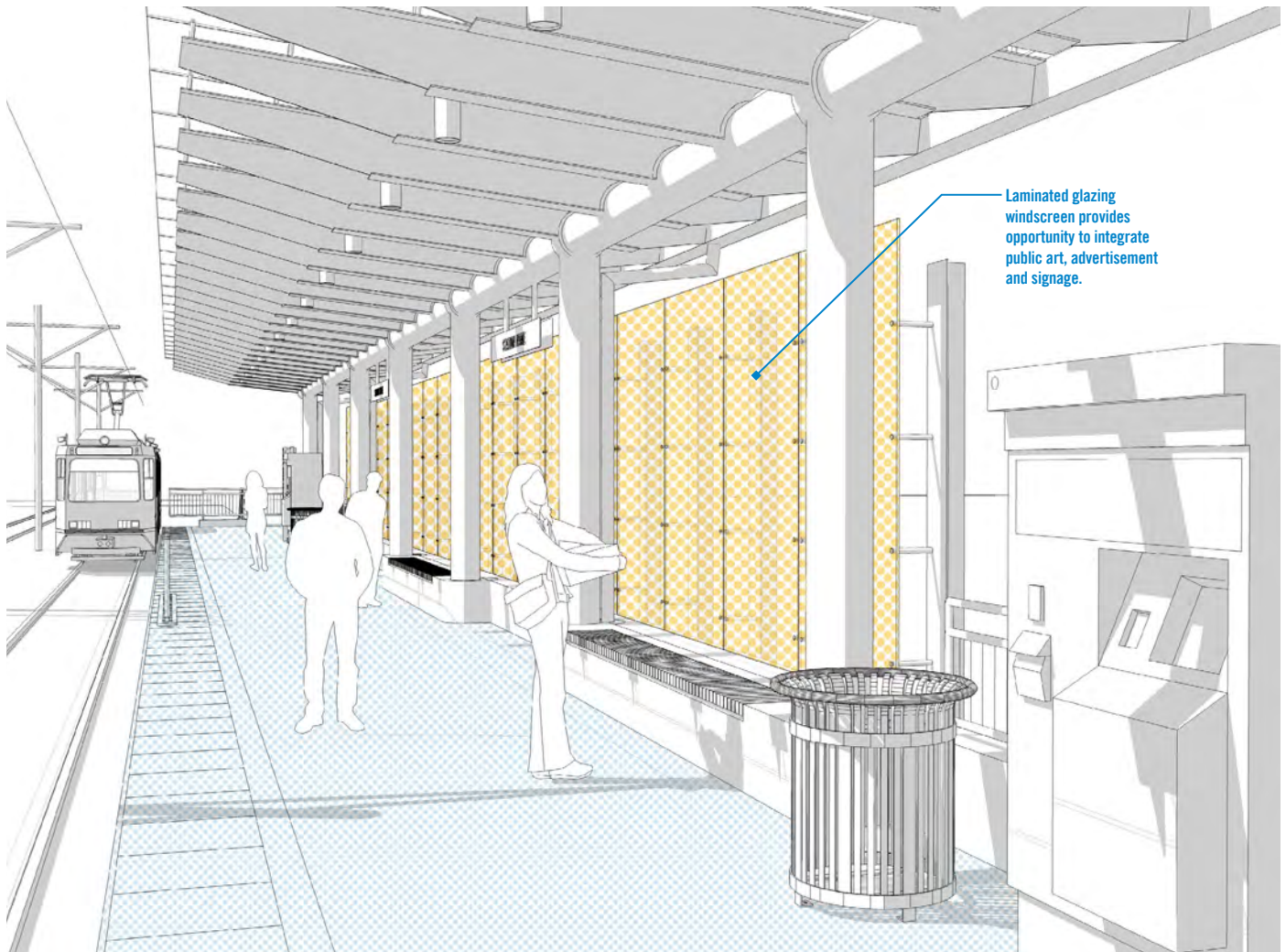

Windscreen Placement

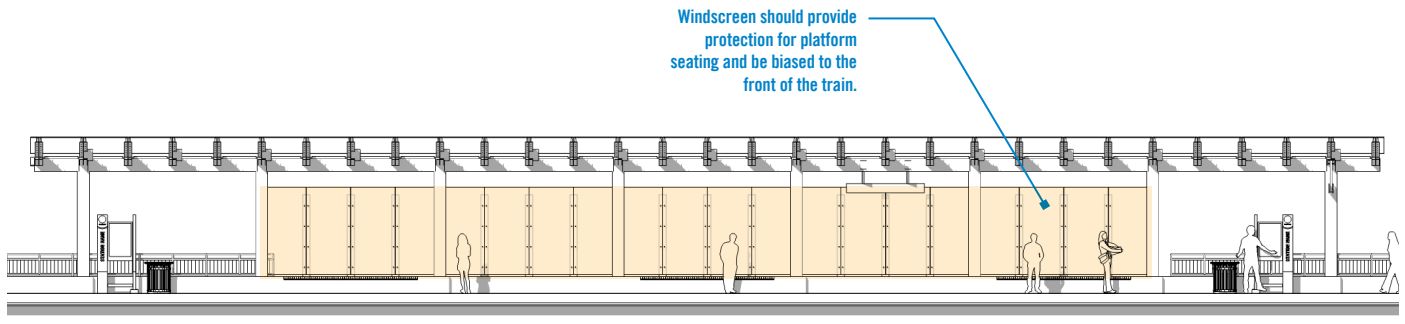

TRASH & RECYCLING RECEPTACLES

Station platforms should always be clean and free of debris. This is important for passengers, as well as local residents, as it makes a statement about the LRT system and how PAAC and users feel about the transit system. A clean platform says we care about the environment and want others to share the same feelings. One way PAAC attempts to keep the platforms clean is by providing trash receptacles.

EXISTING

Types

Like most other platform elements, there are varying types and placement for trash receptacles throughout the light rail system. The two most recognized receptacles include a square-shaped painted steel can and a round painted steel.

Materials

The existing material utilized for the trash receptacles is pre-finished (powder coated) steel.

Location

Existing trash receptacles are in various locations at stations including near entrances, periodically along the length of the platform, and sometimes adjacent to the seating areas. The placement of these receptacles is most effective when located at the ends of the covered canopies.

Challenges

The challenges that face providing trash receptacles at platforms involve the maintenance of the receptacles. The PAAC maintenance staff are required to check and empty the trash on a regular basis, if not daily, which can be difficult when you have multiple receptacles throughout the system. Additionally, the receptacles are subject to vandalism and other deterioration because they are placed outside in a harsh environment.

Opportunities

With new technology, the opportunity exists to provide trash receptacles that indicate when it needs to be emptied; this can reduce maintenance cost and allow resources to be utilize more efficiently.

In addition, to meet the sustainability goals of both PAAC and regional municipalities and the city of Pittsburgh, opportunities for recycling and partnerships with sustainability organizations could be pursued.

REPAIR

Trash receptacles not being replaced shall be painted to match the color for new receptacles.

REPLACE

Trash receptacles should be replaced with new ones as described below.

NEW

The material recommended for new trash receptacles is pre-finished (powder coated) steel because of its durability and low maintenance. The receptacle should be round with open fluted sides and be able to accommodate a 32-gallon trash bag. It should be 33.5 inches tall and have a customized elevated lid.

Trash receptacles shall be placed near passenger boarding areas, placed on each end of a canopy edge, and placed near ticket vending machines. Trash receptacles shall not impede egress or ingress to the platform. Every platform shall contain at least one trash receptacle place near the platform entrance. Category 1 and larger stations shall have a minimum of two receptacles at each end of the canopy or waiting areas. Additional receptacles may be required depending on ridership numbers or need. A minimum of one receptacle per ticket vending machine area shall be provided.

The receptacle's color shall be consistent throughout the system and coordinated with the established color palette for the system.

When possible, similar model receptacles for recyclables shall be provided adjacent to trash receptacles. This coupling of trash and recycling receptacles is more appropriate at high-volume stations.

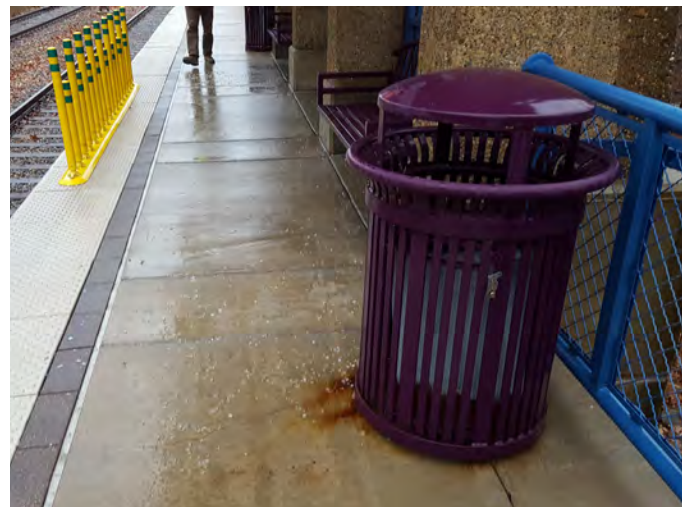

Existing trash receptacle at Boggs Station, Pittsburgh

ADVERTISING

Transit advertising is advertising placed in or on modes of public transportation or in public transportation locations. Ads can be placed on platforms or on station property surrounding the platform. Transit advertisement can be very effective because of a captive audience for a certain period of time, improving the rider experience if implemented correctly.

EXISTING

Types

Advertising is located throughout the LRT system. The advertising is wide-ranging in size, location, and format. There are freestanding billboards and framed signs of different shapes and sizes at many of the larger stations. Some framed signs are attached or integrated into the station design, such as at First Avenue Station. Others are attached to walls or guardrails at various stations.

REPAIR

Because advertisements are typically temporary in nature, they are often changed or updated on a regular basis. This reduces the need to repair most advertising media, but the structure (frame-work or billboard) that supports the advertisement is permanent and may require periodic maintenance. The maintenance may be comprised of metal repair (see Section 3.2) including rust removal, patching, and painting. It is recommended that freestanding billboards be installed on concrete curbs to elevate the bases, thus reducing the potential corrosion from deicing salts.

REPLACE

If the advertising support structure is damaged beyond repair, it is recommended that the structure be replaced in kind or another more effective method be investigated at each station.

NEW

This document is not intended to provide all guidelines and requirements for advertising within the PAAC LRT system, but this is to outline the high-level factors that should be considered at the LRT stations. All advertising should be coordinated with the PAAC's Advertising Department.

Placement

The placement of advertisements is critical for the advertiser and the rider. It must be highly visible as to be viewed by riders (this is critical for the advertiser), but it also must be functional for PAAC and the passengers.

Care should be taken to not allow advertising to visually overpower or clutter customer information, such as schedules, maps, or notices. Customer information should be the priority and primary focus, with advertising not contributing to visual confusion.

To simplify and standardize advertising at the stations, it is recommended that specific areas be planned and designed to house

advertisements. Once other common and required elements of the platform have been established, the advertising should be set up in zones, allowing sufficient space between any other items, and thus ensuring there is a balanced, rhythmic approach. Advertising should be similarly spaced on both sides of the track to create a sense of balance, where possible.

Good areas for advertisement placement are:

- Adjacent to seating or waiting areas on platforms;
- Near station maps or other elements with which the passengers need to view or interact (such as integrated in an Information Display Unit);
- Areas of high pedestrian traffic, such as entries and exits; and,
- Within direct line of sight and head-on so riders do not have to go out of their way to read.

Frames

Print advertising at stations shall be set standard sizes to fit frames and cases. It is critical that care be taken to design structures or billboards that can withstand abuse and/or graffiti. These systems should provide a durable glass covering to protect the advertisement and be easily fixed in the case vandalism occurs. If cases are utilized, the case should be designed to be aesthetically pleasing as a backdrop, so it can stand on its own if no advertisements are placed inside.

As with all form of communications, transit advertising is quickly moving beyond only the traditional print advertisement. New technology has allowed advertisers to explore different mediums in transit advertising. These mediums include digital advertising on plasma or LCD screens, interactive advertisements that allow patrons to scan a barcode with their smart phone, etc. PAAC is beginning to invest in more electronic systems. It is anticipated that this technology will be incorporated at LRT stations in the future. The same guidelines listed above will need to be factored into the types, size, and location of the electronic advertisements.



The standard print signage size is 2-sheets, which should be placed in a durable case near areas of high traffic, such as exits and entries. New York Subway

PUBLIC ART

A summary of the FTA's encouragement of art in public is provided in the Station Property: Public Art section of this document. This section focuses on the public art within the platform limits, which could serve multiple purposes while enlivening the rider experience.

EXISTING

Types

Currently, public artwork exists at the South Hills Junction (SHJ) and a few other light rail stations. The public artwork at SHJ consists of various wall-mounted paintings from various artists.

Materials

Currently, only painted panels are being utilized at the SHJ site.

Challenges

Challenges include finding the proper and adequate locations for public art to allow for public viewing, while providing protection for the art from the weather and/or vandalism.

Opportunities

The opportunities that exist are enlivening the platform, providing pleasant backdrops to areas that can be otherwise mundane, providing interest for the patrons, and creating a piece of art that can be celebrated for years.

REPAIR

There is currently minimal public artwork at LRT stations in the system; therefore, limited to no repair is currently required. As the artwork ages and more artwork is included throughout the system, it will require maintenance and repair according to its character.

REPLACE

If and when it is deemed necessary to remove and/or replace existing artwork within any station, special consideration should be made. The removal and replacement of existing art should take into consideration the type of art, the artist's desire to retain, the difficulty in removal, the care required to protect the art, and what will replace the art.

NEW

Placement & Orientation

Public artwork should be placed to provide the greatest impact to the patron while carefully being coordinated with other elements of the guidelines and with the overall design of the station. Art provides the opportunity to reduce negative impacts related to noise and visual barriers and help effectively strengthen the overall goal of providing clear pathways and visual clues to entry points and wayfinding needs.

Design professionals should strive to design structures and facilities that both inspire current populations, as well as future ones through their artistic and architectural elements. A second reason to include artistic elements in transit design, is that art—if done properly—can reduce vandalism. Inclusion of art in transit facilities can encourage a community to take ownership of the facility, increasing the public watchfulness over the investments placed at the facility. Successful public art is well-integrated with its surroundings to enhance rather than disturb its environment.

Public art at platform can take many shapes and forms: painting, fencing, lighting, etc. At platforms, it is usually found on the canopies or windscreens. All designs must be safe and welcoming for all. An installation should not interfere with boarding of transit vehicles; designs should be suitable in size, scale, and materials for the requested location. Materials must be safe and able to meet maintenance and lifespan expectations. Any artwork at platforms must be approved by PAAC.

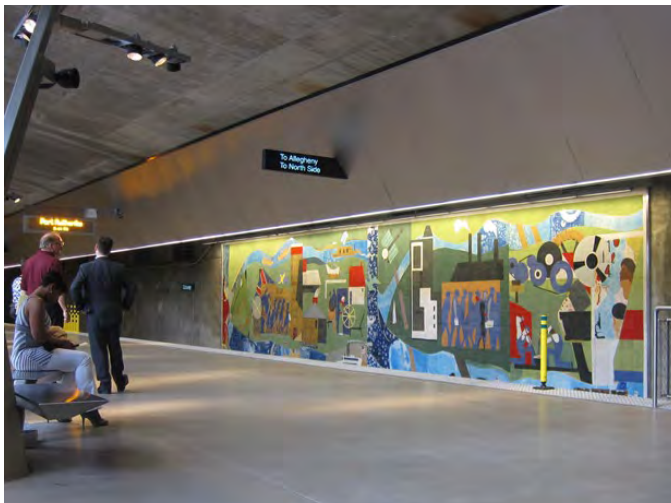

Consider placing art on expansive vertical surfaces & wall. Romare Bearden's Pittsburgh Recollections at Gateway Station, Pittsburgh



Consider sculptures as shade elements or platform canopies, which can also be seen from the public right-of-way. Laura Haddad's Cloud Cloud canopy at Angle Lake Station, Seattle

Size & Configuration

The art size and configuration shall be coordinated with the station design team early during planning phase, so the greatest integration of design elements and common design approach can be achieved.

Construction

The artwork must be of high quality, be site specific, and require minimum maintenance to resist graffiti and vandalism.

Accessibility

The artwork should not conflict with any mobility or visual accessibility requirements. Careful consideration should be given to how the art should be experienced and if patrons with physical limits have access to and cannot conflict with the artwork.

Material

The artwork materials should be durable and meet the same general principles and material considerations as any other station elements, including maintenance cleaning and salt or other weather exposure.

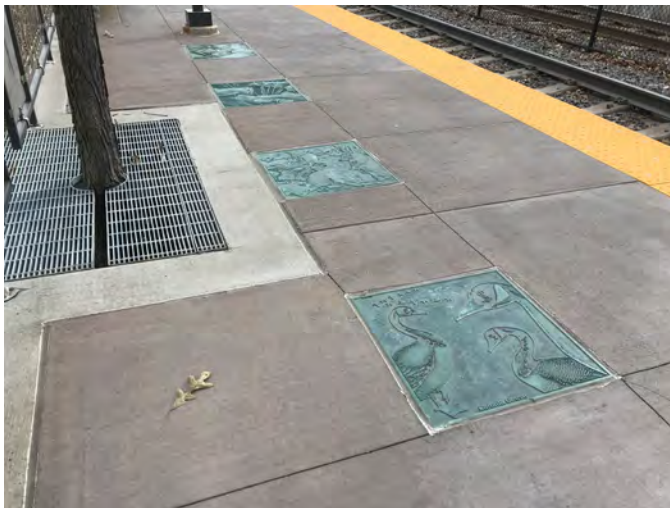

Integrate public art into paving and platform floor materials. Andrews LeFevre Studios' Hiawatha Native Species Series pavers at Minnehaha Station, Minneapolis



Incorporate design into windscreens and paving. Merge Conceptual Design's Room Within windscreen and pavement at Arena BRT Station, San Jose



Color, translucency, natural light, and variety are also important artistic qualities that should be considered. JoAnn Verburg's 3D canopy at 46th St. Station, Minneapolis



Engage with local history & context whenever possible. Stephen Farley's Downtown Justice pavement at Jefferson / 1st Ave. (Superior Court) Station, Phoenix

TECHNOLOGY & SIGNAGE

Overview

Transportation, along with every other industry, is being impacted by technology. Patrons have an ever-increasing desire for convenience, connectivity, and information. Additionally, as PAAC strives to improve service and increase ridership, it is confronted with integrating technology within its system. This section focuses on technological improvements and different aspects of signage and wayfinding.

Technology & Signage Elements

- Signage
- Ticket Vending Machine
- Information Display Unit
- Validator
- Call Box / Emergency Button
- Patron Notice Board
- Public Address System
- Surveillance Camera
- Real-Time Arrival Information
- Technology Integration



Sidewalk signage informs pedestrians of median platforms, directions, and line/route.
Hamline Ave. Station, St. Paul



Information kiosks which includes ticket kiosks, maps, schedules, and notices.
Sodo Station, Seattle

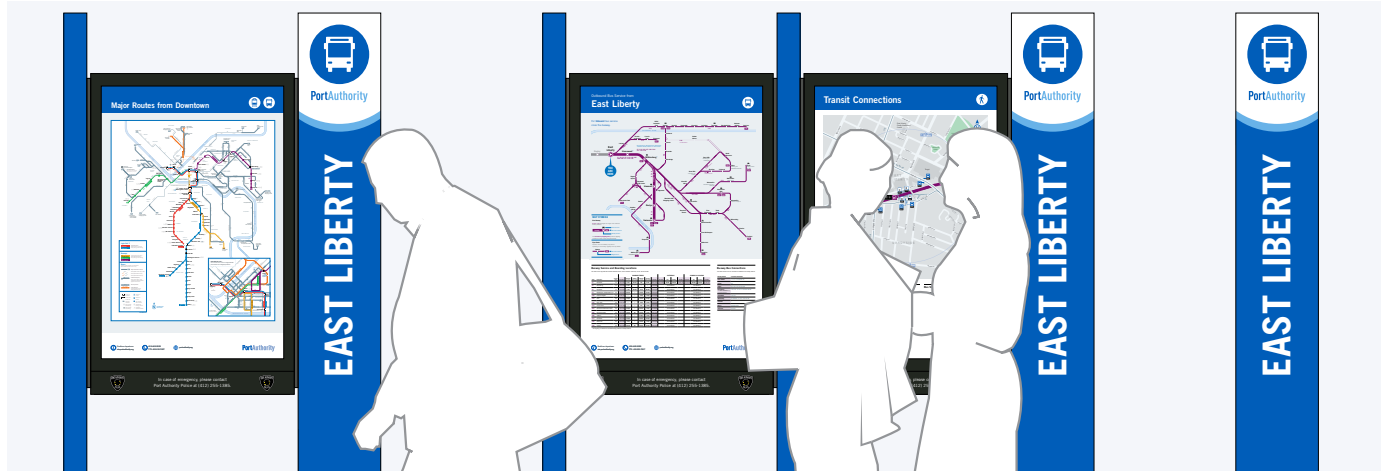

Technology & Signage

- | | |
|---|--|
| A Identity Signage | G Validator |
| B Station Identification Signage | H Call Box / Emergency Button |
| C Directional Signage | I Patron Notice Board |
| D ADA Signage | J Public Address System |
| E Ticket Vending Machine | K Surveillance Camera |
| F Information Display Unit | L Real-Time Arrival Information |

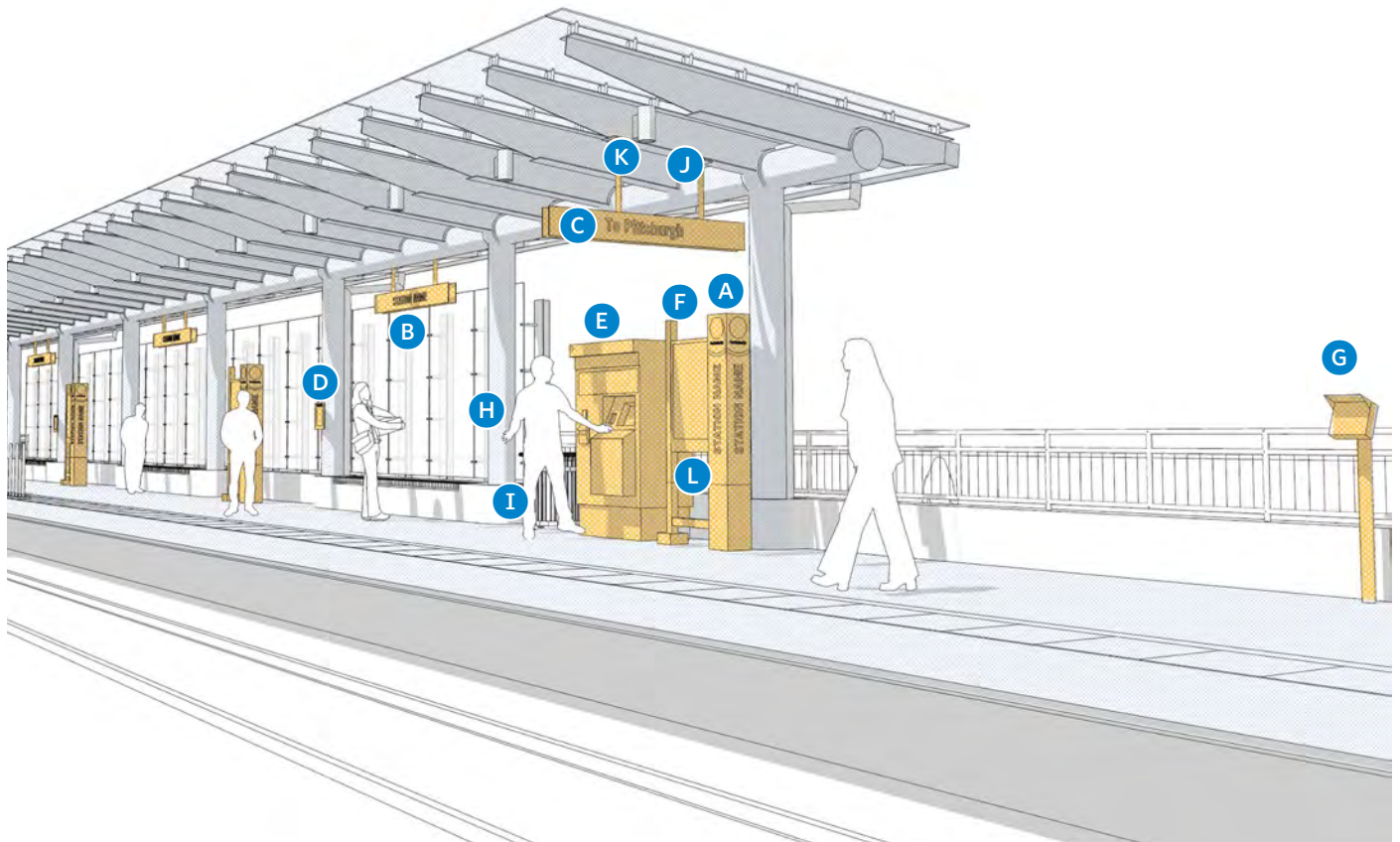

SIGNAGE

Overview

Basic goals for signage are to guide passengers through the system and stations in the most efficient and least complicated way, to provide orientation and information required by the rider to aid in directional decision-making, to warn passenger of system hazards, and to provide safe exit in case of emergency from the platform and station.

This document provides guidance related to the general signage types, placement, orientation, and guiding principles. PAAC has a separate set of signage guidelines that provides more detail related to each sign type, font, text height, color, and accompanying symbols. Throughout the guidelines there are many references to good signage principles as seen in the following sections:

- General principles consistent and appropriate signage
- Coherent site design
- Color palette
- Bus shelters
- Bicycle parking
- Passenger drop-off area

The general types of signs to consider can be defined as follows:

- **Identity Signage** : To provide a recognizable symbol / beacon for riders entering the station property from other modes of transportation. According to the PAAC signage guidelines, the ID signs are totem style 4-sided signs located at transit facility entrances. They are illuminated using an existing power source.
- **Station Identification Signage** : Provide pedestrians and passengers within the vehicle a clear visual of the approaching station name.
- **Directional Signage** : To aid the passenger in decision making, directional signage shall be provided at the platform indicating the major destination and/or terminus station (e.g. “To Library”) to orient the rider to the correct platform.
- **Wayfinding** : To assist passengers in navigating to and from the station. Wayfinding signage shall be provided indicating other significant modes of transportation like bus, shuttle, or passenger pick-up areas.
- **Safety** : To warn passenger of system hazards and safe exit safety. Signs shall be provided indicating egress points and PAAC personnel areas only areas.
- **ADA Signage** : To comply with ADAAG, signage shall be provided to indicate direction to and identify the accessible entrance and assessable routes.

ADA guidance for transportation facilities (<https://www.access-board.gov/guidelines-and-standards/transportation/facilities/about-the-ada-standards-for-transportation-facilities/ada-standards-for-transportation-facilities-single-file#a703>) and other best practices should be utilized to define ideal standards for the location of each sign type (assuming size will be defined in the signage guidelines). Determining mounting and detail connection case by case is acceptable, but a common solution is preferable for visual consistency.

EXISTING

Types

There are numerous existing sign types that vary greatly within the station categories. The Stage II stations have the most comprehensive type and number of signs. All the stations have Station Identification Signage to let the passenger know what the station name is and directional signage indicating the next stop on the line. The other sign types --identity, wayfinding, safety, and ADA --are limited or inconsistent.

Materials

The station identification signs and directional signs are typically printed or painted onto sheet metal panels and inserted into a metal frame. There are also ADA signs that printed onto polycarbonate plaques that allow for raised braille.

Challenges

Many of the signs are faded and worn over time when exposed to weather and UV sunlight.

Opportunities

Replacement of station signs is an opportunity to both reevaluate the wayfinding effectiveness and provide an aesthetic improvement to the system.

REPAIR

If a sign is damaged or significantly deteriorating, it shall be replaced. Replaced signage should be relocated according to the new guidelines for spacing and height to ensure maximum visibility, accessibility, and consistency.

REPLACE

Replacing of signage should occur when the sign or sign support are beyond repair or refinishing. Replaced signage should be relocated according to the new guidelines for spacing and height to ensure maximum visibility, accessibility, and consistency.

NEW

Placement & Orientation

- Identity signs should be placed within parking lots and near station entry points (see Signage: Identity for placement standards).
- Station identification signs should be placed at certain intervals along the boarding platform, in prominent locations and visible from within the vehicle on both sides (see Signage: Station Identification for placement standards).
- Directional signage should be perpendicular to the track and near the platform area (see Signage: Directional for placement standards).
- ADA signage shall be provided per the ADA standards. Signage should be placed on platforms to inform riders where the nearest accessible exit and/or ramp is, and placed near station entrances to inform arriving riders where the nearest accessible path to the platform is located (see Signage: ADA for placement standards).

Size & Configuration

The sign size should be based on the proximity from the viewer and to allow the proper text height. The sign configuration should be based on the amount of text needed to convey the message.

Construction

Signage should be constructed of durable materials with a finish that is UV resistant.

Accessibility

Signage shall comply with the requirements of the ADA Standards for Accessible Design Section 4.30, and the MUTCD where applicable.

Font, Color, Text Sizing, & Text Spacing

Refer to PAAC's Passenger Information Products Design Standards Document for guidelines on signage content design, including font, color, text sizing, text spacing, and product dimensions.

The placement and orientation of this signage shall follow this LRT Station Design Guidelines document.

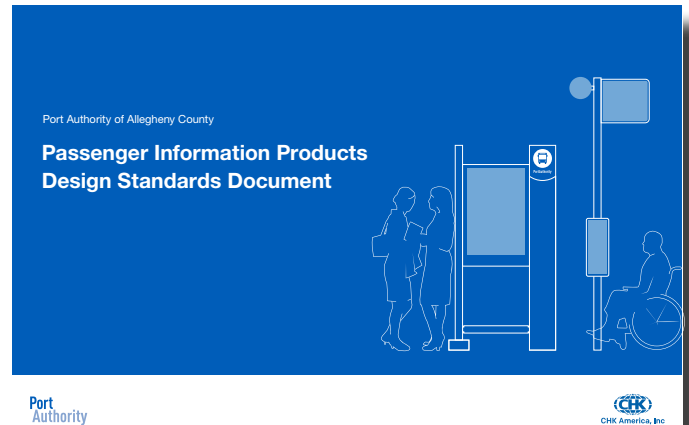

PAAC's Passenger Information Products Design Standards Document shall be followed for signage content design guidelines.

SIGNAGE: IDENTITY

Identity Signage is located near the edge of the station property and the public right-of-way. It is often the first sign and visual interaction the public has with the station, so it should be well-placed to carry the PAAC brand.

There should be two applicable Identity Signage sizes with their respective locations on a station property:

1. A smaller, pedestrian-scaled sign (pylon - approximately 7'-0" tall) located near pedestrian entrances to the platform. These signs are primarily meant to identify the station entrance. These pylons are also used in conjunction with the IDUs at the platforms for consistency.
2. A larger sign (totem - approximately 10'-0" tall) directed towards drivers located near commuter parking lot entrances.

For Identity Signage near pedestrian entrances, such as entry plazas or platform ramps, the signage should be pedestrian-scaled, and not be obstructed by other structures or plantings. The signage should also be lit either by an external light source or internally lit for evening use. Therefore, a power source should be provided.

For stations with adjacent commuter parking lots or parking structures, place Identity Signage near the vehicular entrance from the public street. These signs will need to be at a larger scale for drivers to see, and also should be lit for evening use.

PAAC's "Passenger Information Products Design Standards Document" has a set of Identity Signage pylons that shall be used appropriately for their respective locations: a 7-foot-tall pedestrian-scaled IDU pylon, and a 10-foot-tall totem. The aesthetics of signage must be updated as the standards change overtime, while following the above placement guidelines of this document.

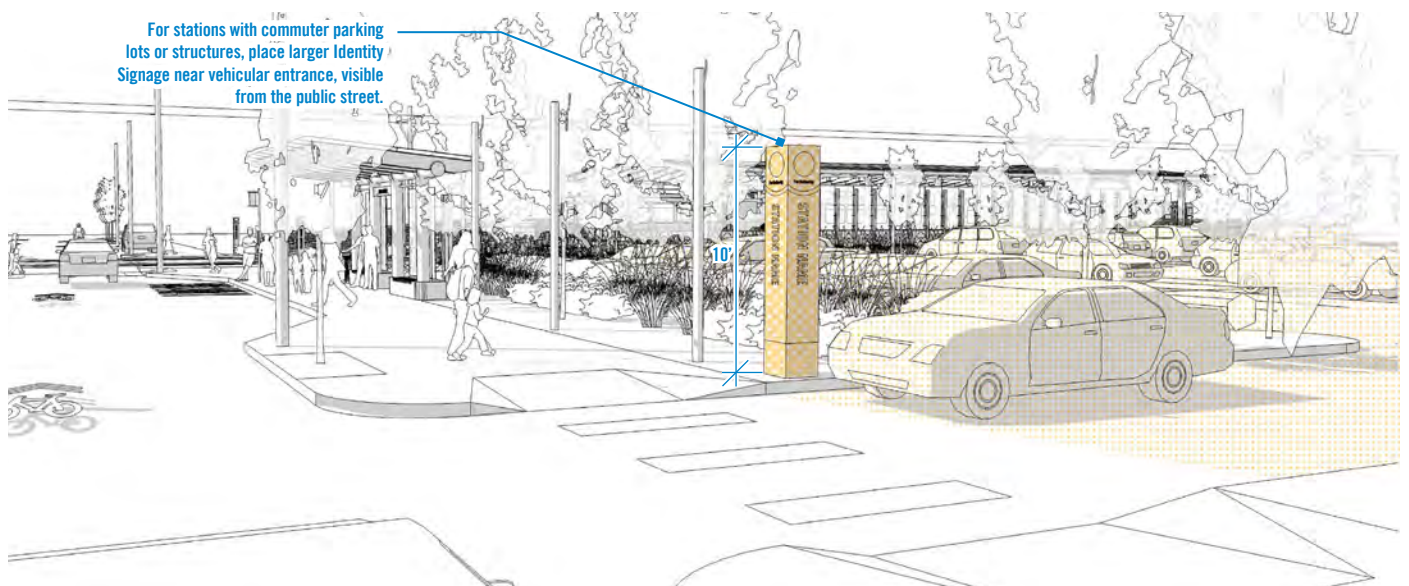
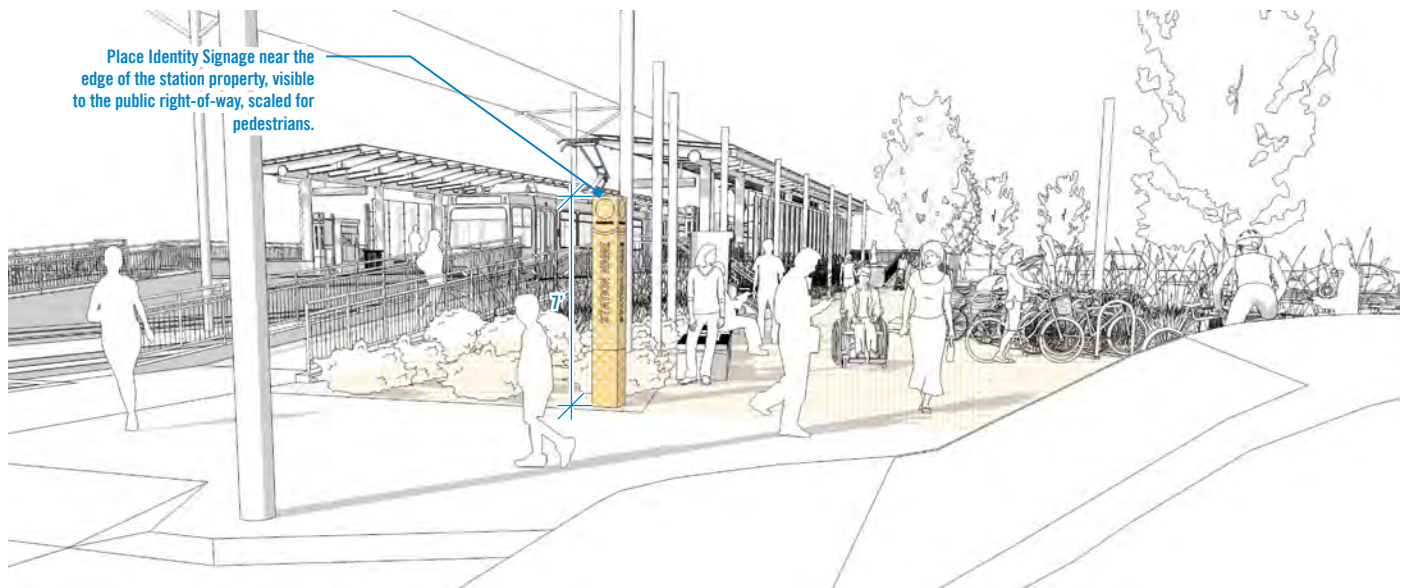

SIGNAGE: STATION IDENTIFICATION

Station Identification Signage is for passengers riding inside a moving transit vehicle to identify which station they have arrived at. Therefore, these Station Identification Signage need to be oriented parallel to the rail tracks, and located 9 feet above the ground to avoid being visually obstructed by other platform elements. Station Identification Signage should be well-lit by an external light or internally for evening use.

All stations must have at least one Station Identification Signage. Category 1 shall have four signs, and Category 2 and Category 3 stations shall have three signs. All signs shall be biased towards the front of the platform, or the location where the trains stop for boarding and alighting.

For stations with multiple Station Identification Signage, the signs shall be spaced no more than 35 feet apart, on center. Depending on the station, these signs should be hung from a canopy, centered between structural bays for visual consistency and symmetry. For stations without canopies, signs should be mounted on platform light poles, or a metal pole might need to be provided if no vertical elements exists.

The PAAC’s “Passenger Information Products Design Standards Document” has a set of fonts and colors for signage which shall

be used. The aesthetics of signage should be updated as the standards change overtime, while following the above placement guidelines of this document.

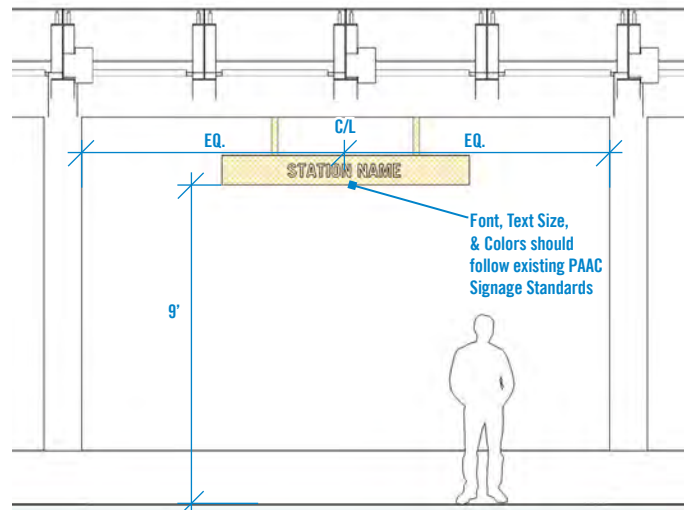

Typical station identification signage installation, parallel to tracks & attached to canopy central beam.

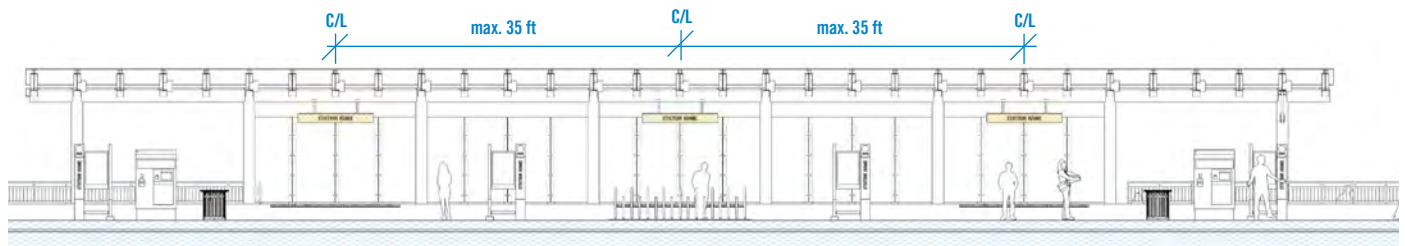

Stations with long canopies, such as at Category 1, Category 2, and Category 3 stations, should have 3 Station Identification Signs mounted from the canopy, no more than 35 feet apart on center.



For stations with no canopy or overhead structure, mount Station Identification Signage on a vertical post, such as a light pole or provide one.

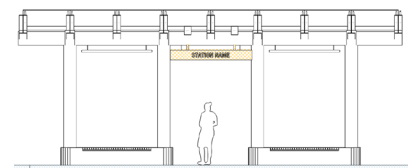

Stations with short canopies, such as at Category 4 and Category 5 stations, should have 1 Station Identification Sign centered mounted to the canopy.

Number of Station Identification Signage

Station Category	# of Signage Minimum
Category 1	4
Category 2	3
Category 3	3
Category 4	1
Category 5	1

SIGNAGE: DIRECTIONAL

Directional Signage is focused towards transit riders as they approach the platform, and informs the riders which directional terminus the train at that platform is heading towards. The text should be coordinated within PAAC operations to maintain consistency through the system.

If a canopy structure is present at the station, the Directional Signage should be placed under the canopy at both ends. If no canopy is present, place Directional Signage on another vertical structure such as a light pole, or provide one.

These Directional Signage should be perpendicular to the tracks, and be placed near the pedestrian entrance onto the platform. For central platforms, Directional Signage for each direction should be placed together, near the pedestrian entrance onto the platform.

For separate, facing platforms, the Directional Signage should be placed at the same location on each platform, preferably mirrored from each other. At stations and station property, additional wayfinding signage may need to be placed throughout the station property if there are common paths of travel to the platforms that diverge to access the different platforms. These station property wayfinding signs should be placed at pedestrian eye-level and pedestrian scale.

For stations serving multiple lines or routes, distinction between the different terminuses should be provided with two different directional signs.

PAAC's "Passenger Information Products Design Standards Document" has a set of fonts and colors for signage which shall be used. The signage standards are to be used for specific guidance while implementing these guidelines.

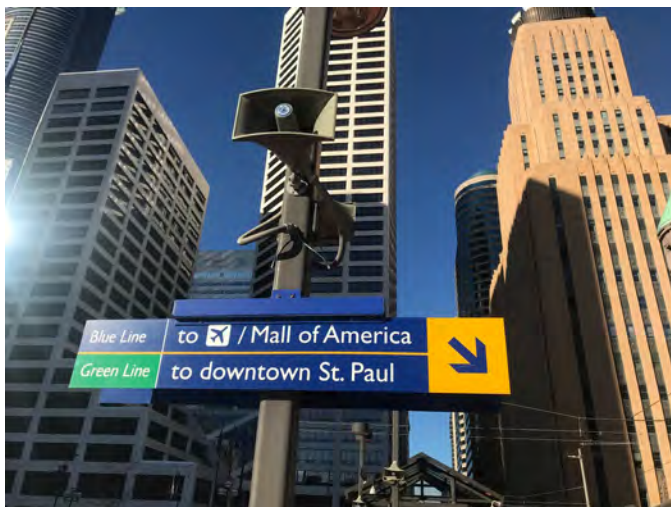

For stations serving multiple lines, provide Directional Signage for both lines at the same location. Government Plaza Station, Minneapolis



For center mounting stations, place Directional Signage on the same vertical posts perpendicular to the tracks. East LA Civic Center Station, Los Angeles

SIGNAGE: ADA

At stations where there is a different accessible route than the common path of travel, signage must be provided to direct those needing an accessible route.

This ADA Signage should be placed on platforms for alighting transit riders to direct them the accessible route off of a platform, either to a ramp or elevator. These signs shall be placed facing the platform, at an ADAAG required height.

ADA Signage should also be placed around the station property for riders arriving to the station, directing them to the accessible route onto the platform, either to a ramp or elevator. Throughout the station property, ADA signage should be located along the accessible path and placed at any point that may cause confusion or where the rider may lose sight of another ADA directional sign.

This ADA Signage shall conform to ADAAG requirements.

The PAAC's "Passenger Information Products Design Standards Document" has a set of fonts, colors, and accessibility iconography for signage which shall be used. The signage standards are to be used for specific guidance while implementing these guidelines.



ADA Signage on the platform should inform alighting riders which way to the accessible exit route. Willow Station, Pittsburgh



ADA Signage should be placed along the station property to direct arriving riders the accessible routes to the platform. South Pasadena Station, Los Angeles



ADA Signage should be placed along the station property to direct arriving riders the accessible routes to the platform. East Liberty Station, Pittsburgh

TICKET VENDING MACHINES

Ticket vending machines (TVM) allow riders to purchase fares, add value to their pass, and generate proof of payment. The benefit of TVM is that riders can purchase with multiple forms of payment including credit cards and cash.

EXISTING

There are existing ticket vending machines located throughout the system and at various locations before or on the platforms. At the larger platform with large canopies, TVMs are located on the platform to provide weather protection and convenience to the rider. At some of the smaller stations, TVMs are located prior to the platform, usually at what might be considered the threshold to the platform.

REPLACE

If a TVM needs to be replaced, improvements noted in the “NEW” section, such as location and orientation, should be considered.

NEW

Location & Orientation

TVMs should be located at the threshold to the platform as to not

Number of Ticket Vending Machines

Station Category	# of TVMs per Platform	
	Minimum	Central
Category 1	2	3
Category 2	1	2
Category 3	1	2
Category 4	1/ varies	1/ varies
Category 5	1/ varies	1/ varies

clutter the platform, nor create queues of patrons trying to buy tickets. The threshold to the platform can be directly before a set of stairs or ramps that lead up to the platform, or in an adjacent entry plaza. Additionally, placing TVMs prior to platforms at the threshold doesn't preclude PAAC from implementing fare-paid zones in the future.

However, for Category 1 or stations with larger platforms, additional TVMs may be placed on the platform near entrances. These additional TVMs should only be considered if room on the platform permits, with a minimum clearance of 8 feet (10 feet is preferred).

TVMs shall not block accessible and pedestrian paths. They shall be oriented with the front interface panel facing the path of travel, with consideration for queueing that must not block the path. If the location is up against a limiting surface such as a wall or guardrail, the TVM should be placed as close to the surface to prevent patrons from accessing the rear of the machine.

TVMs should be installed in adequate numbers to support passenger during peak hours. Category 1 stations shall provide at least two TVMs per platform (central platforms shall provide at least three). Category 2 and Category 3 stations shall provide at least one TVM per platform (central platforms shall provide at least two). Category 4 and Category 5 stations, due to their limited and constricted station area, as well as a lack of infrastructure, should provide one TVM if feasible.

If possible, provide a shelter or canopy over TVMs both for the safety of the equipment and for the protection of patrons purchasing tickets. This area around the TVMs should also have safety infrastructure coordinated nearby, such as lighting, surveillance cameras, and call box. Power and data should be provided at the ideal location. If possible, couple IDUs or information kiosks adjacent to TVMs for customers requiring a central and logical station area for information.



Off-platform ticket vending machines placed at the threshold to the platform at Atlantic Station, Los Angeles.



On-platform, covered ticket vending machines, placed with validator and emergency button, at Government Plaza Station, Minneapolis.

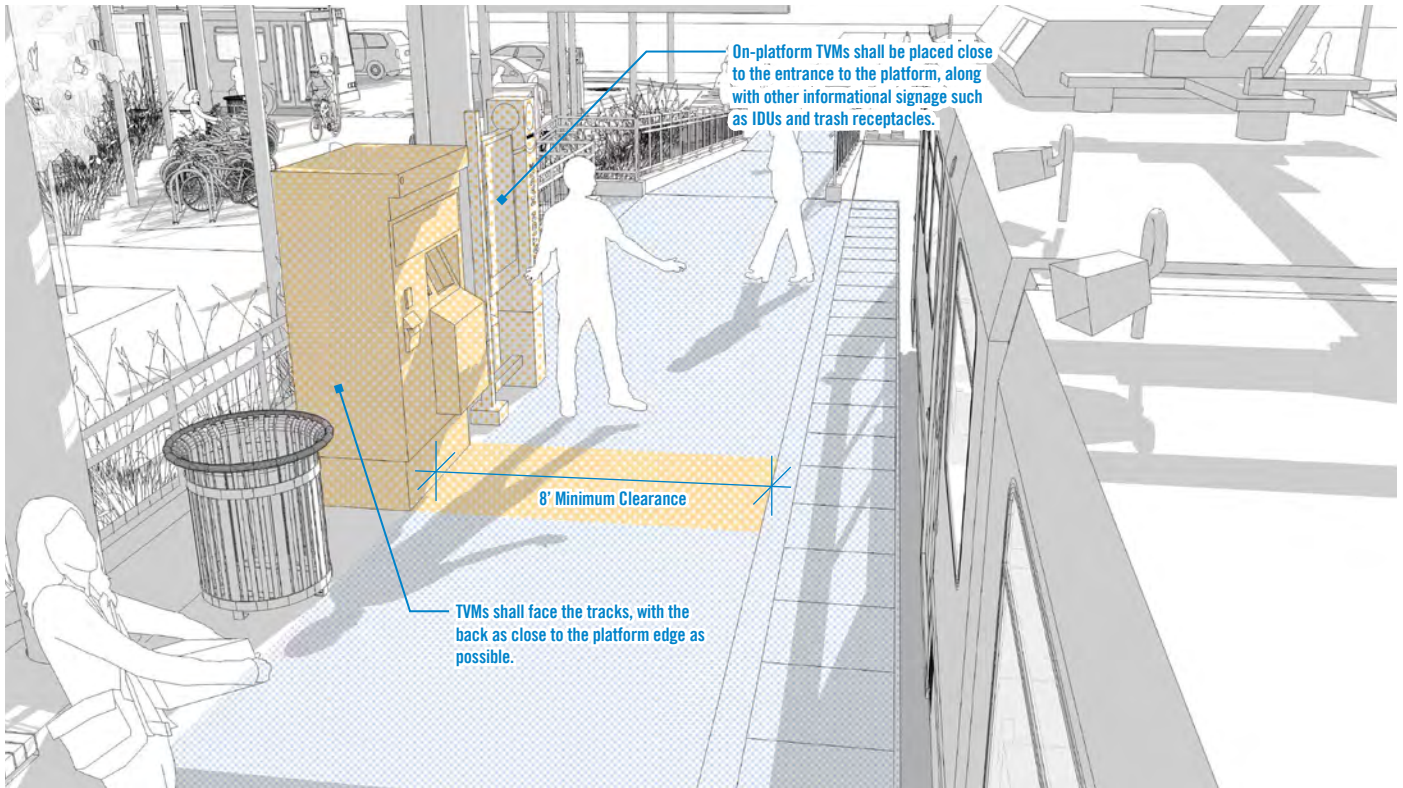

On-platform placement of ticket vending machines should only be considered for Category 1 stations or stations with larger platforms.

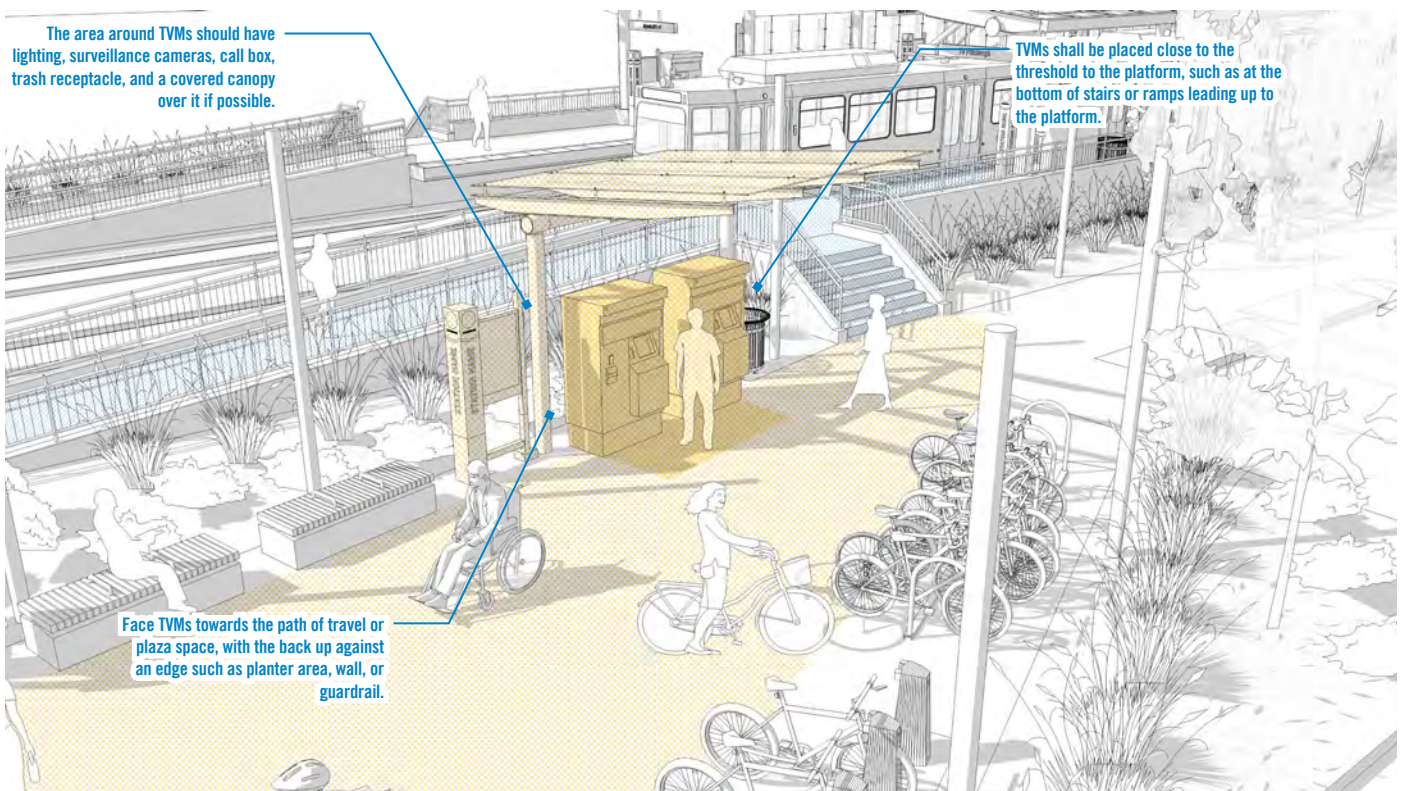

For stations with narrow platforms, ticket vending machines should be placed off the platform, close to the threshold to the platform or in an entry plaza.

INFORMATION DISPLAY UNITS

The Information Display Units (IDU) shall follow the signage standards as provided by the Port Authority of Allegheny County and provides a consistent framework to support passenger information associated with schedules information, system maps and local area maps. The IDU will help protect this critical information from weather and vandalism, while improving the station image and brand. In addition to map and schedule information, the IDU can also be added to by providing a power source and additional display panels to include:

- Patron notice board with important information related to upcoming services disruptions and schedule changes;
- Real-time arrival display panel providing current information related to service, schedule and delays; and,
- Advertisement display panel.

EXISTING

Types

There are numerous existing approaches to displaying maps, schedules, patron notice, real-time arrival and advertisements throughout the LRT system. This non-standardized method of displaying important customer information, such as maps and schedules, makes it difficult for PAAC staff to easily and regularly update the information in the kiosks, and makes riders confused when information is not up-to-date nor accurate.

The PAAC's "Passenger Information Products Design Standards Document" has a set Information Display Unit product which PAAC has implemented at some fixed-guideway stations, and has plans to introduce them throughout the network.

Opportunities

Replacement of the information into a single unit will provide for more constancy and a better image for each station.

REPLACE

If the supports of frames are beyond repair, the IDU should be replaced

NEW

Placement & Orientation

For stations with wide platforms, IDU should be placed on platforms near major passenger gathering and waiting areas. IDUs shall be oriented with the informational front face facing the tracks. For central platforms, IDUs shall be placed at the center of the platform, with both sides of the IDU populated with information facing the tracks.

For wide platforms that also have TVMs located on them, the IDUs shall be placed adjacent to the TVMs to create a centralized customer information area.

If platforms are too narrow to provide an IDU without impeding accessible paths-of-travel, locate IDUs as close to the platform threshold as possible, such as at the bottom of stairs or ramps that lead up to the platform.

For Category 1, Category 2, and Category 3 stations, a minimum of two IDUs shall be provided per platform (provide two for central



platforms). These IDUs shall be spaced out evenly along the platform. For Category 4 and Category 5 stations, provide one IDU per platform if space permits.

For stations with entry plazas, additional IDUs should be placed in the plaza in an accessible and open space. When possible, IDUs should be placed along with TVMs in plazas to create information zones for riders to easily locate. These areas shall be well-lit, and protected from weather with a canopy or cover if possible.

IDUs should be placed up against a flat surface, such as a wall or guardrail, if possible. The space between the IDU and the back surface should be limited.

With the potential for electronic display screens to be inserted into the IDUs, electricity and data must be hooked up into the IDU location. In addition, power infrastructure can also serve as site

lighting around the IDU for visual clarity and safety in the evening.

Refer to the “Passenger Information Products Design Standards Document” for PAAC’s latest IDU product. The respective PAAC department should be involved in coordination when placing new IDUs at LRT stations.

Number of Information Display Units

Station Category	# of IDUs per Platform	
	Minimum	Central
Category 1	2	2
Category 2	2	2
Category 3	2	2
Category 4	1 / varies	1 / varies
Category 5	1 / varies	1 / varies



Customer information shall be consolidated into an area or zone, usually placed next to TVMs near the threshold onto platforms. Sodo Station, Seattle

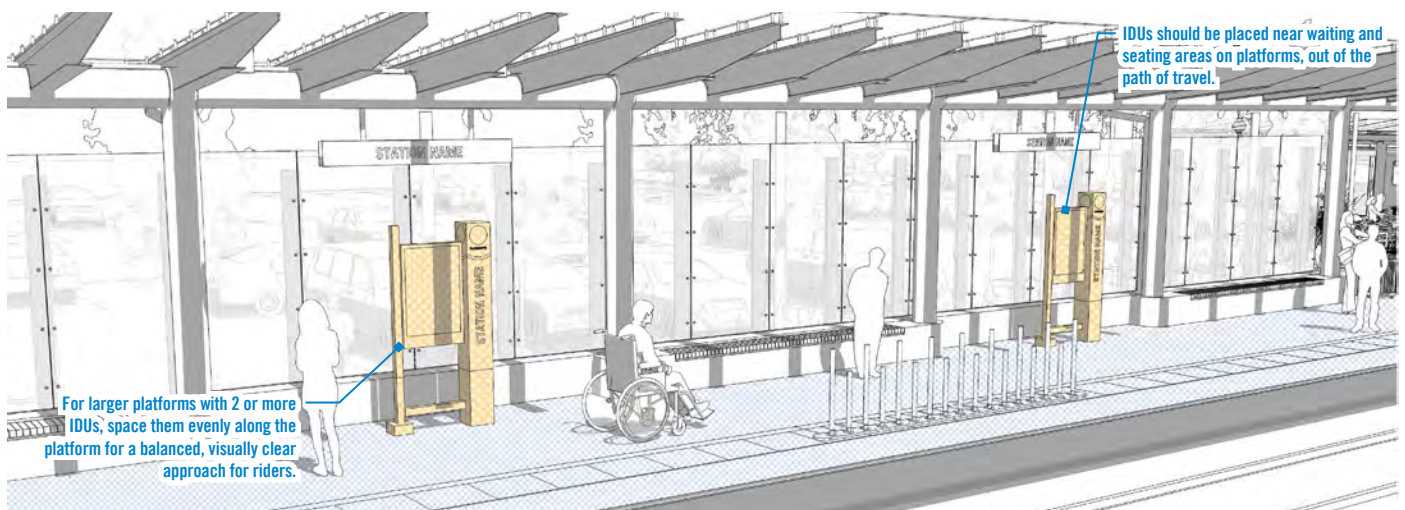

VALIDATORS

Validators are part of the overall fare collection system and play a key role in expediting passenger movement and time spent at arrival to the station. The validator scans the pre-purchased ticket or passes to determine if the ticket has sufficient funds applied.

EXISTING

The existing validators are located prior to the station platform ramps and steps to provide the easiest and most convenient access to the riders as they approach the station.

NEW

Validators should be located at the entry to the platform, with consideration for transit riders as they approach and enter onto the platform. The location can be at the top of a set of stairs or ramps that lead up to the platform.

Additionally, by placing validators prior to platforms at the threshold, PAAC is not precluded from implementing fare-paid zones in the future.

Validators shall not block accessible and pedestrian paths. They shall be oriented with the front interface panel parallel to the path of travel.

Validators should be installed in adequate numbers to support passenger during peak hours. Category 1 stations shall provide at least two validators per platform (central platforms shall provide at least four). Category 2 and Category 3 stations shall provide at least one validator per platform (central platforms shall provide at least two). Category 4 and Category 5 stations, due to their limited and constricted station area, as well as a lack of infrastructure, should provide one validator if feasible.

Number of Validators

Station Category	# of Validators per Platform	
	Minimum	Central
Category 1	2	4
Category 2	1	2
Category 3	1	2
Category 4	1 / varies	1 / varies
Category 5	1 / varies	1 / varies



Validators shall be placed at the entrance to the platform. Snelling Ave. Station, St. Paul

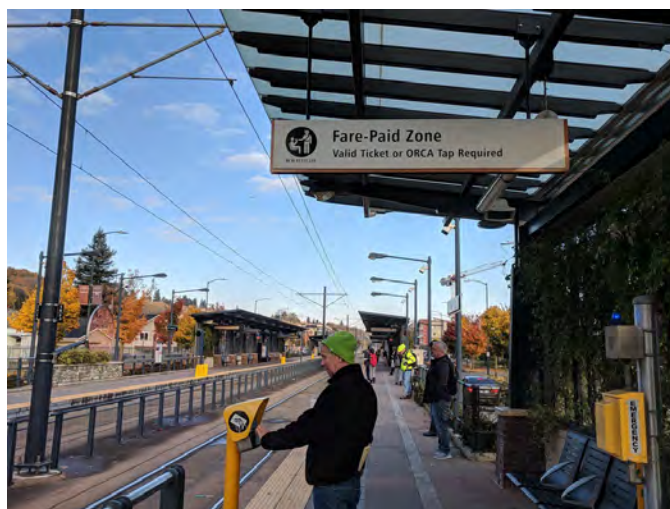

Validators shall face the path of travel. Columbia City Station, Seattle

CALL BOX / EMERGENCY BUTTONS

Emergency call boxes (ECB) are an integral part of the overall safety and security plan for the system. They are intended to facilitate quick communication with PAAC in the event of an emergency situation. They are used for direct emergency-only communications between a passenger and the Operations Control Center.

EXISTING CONDITIONS

Types

There are different types of existing call buttons with the most recent example best illustrated at the Blue Line station platforms.

Materials

The box is constructed of heavy steel and coated a color yellow to stand out to the passenger

Challenges

A challenge is finding a surface that is large enough to support a box and accommodate the connection wire needed

Opportunities

To establish a more integrated and standardized call box/emergency button that can be accommodated with any structure size or configuration.

REPAIR

Repair as required to maintain service and per the supplier recommendations

REPLACE

Replacement only with new PAAC approved box

NEW

Placement & Orientation

It is important to have at least one ECB at each station, accessible to the public, and in a prominent location with appropriate signage. Maintain a maximum travel distance of 200 feet to the nearest ECB from any point on the platform.

Materials

The enclosure shall be easily opened yet vandal resistant, UL rated, and shall comply with applicable code requirements including ADAAG minimum standards such as height above the platform, tactile, braille, and other identification for visually impaired patrons.



Existing ECB integrated into the structural column of the canopy structure along the Blue Line, Pittsburgh.

PATRON NOTICE BOARDS

The patrons are the most important element of the LRT system. When they decide to utilize the LRT, they depend on reliable service. It is important to keep the patron abreast of any changes, disruptions, or planned or unplanned stoppage in service. To accomplish this, PAAC provides a patron notice system throughout the public areas that are intended to provide information and/or messages to the passengers.

EXISTING

Types

The existing patron notice system varies from visual placards, to posted flyers taped to poles, to electronic notice boards mounted or hung under canopies. The paper notices are usually mounted at a height within normal eye view.

Material

The materials utilized for the electronic message boards are aluminum and glass. The majority of the posted notices are paper flyers.

Challenges

The challenges with the posted notices are locating them in a proper, consistent location that is easy for the riders to locate and read, as well as posting them in a manner that protects them from the weather and vandals.

Opportunities

Opportunities exist to improve the patron notice system at the stations. The existing electronic message boards can be replaced with new digital technology that can be integrated with the other proposed electronic platform-mounted equipment. This can potentially eliminate the need for paper/flyer notices. If the paper notices are to remain, a designated information case could be installed to protect the notice and provide a single location for patrons to look for important information.

REPAIR

Damaged electronic notice boards should be repaired with in-kind new equipment.

REPLACE

Replace any damaged or non-functioning electronic notice boards with new electronic/digital notice boards

NEW

LRT stations should include a patron notice system comprised of signs and/or boards to convey information or alerts relating to service changes, detours, system disruptions, or safety information.

Ideally, patron notices should be integrated into IDUs or in electronic display boards. The IDU is a logical place where riders will go to seek out information. The designer will provide sufficient dedicated conduit capacity to support any electronic equipment installed into IDUs for Patron Notice.

If a station does not have an IDU, a small case should be provided to attach an 8.5" x 11" piece of paper to, either as a cork board or a flat surface to tape notices to. This case should have a protective cover to protect the notice from weather. The case should have a key access, allowing only pertinent, official information to be posted. This case should be mounted near platform entrances, on a vertical element such as a light pole or a canopy structure. This placement makes sure that all arriving patrons have an opportunity to see any notices.

All Patron Notice Boards, regardless of cased within an IDU or in a separate case, shall meet current ADAAG requirements.

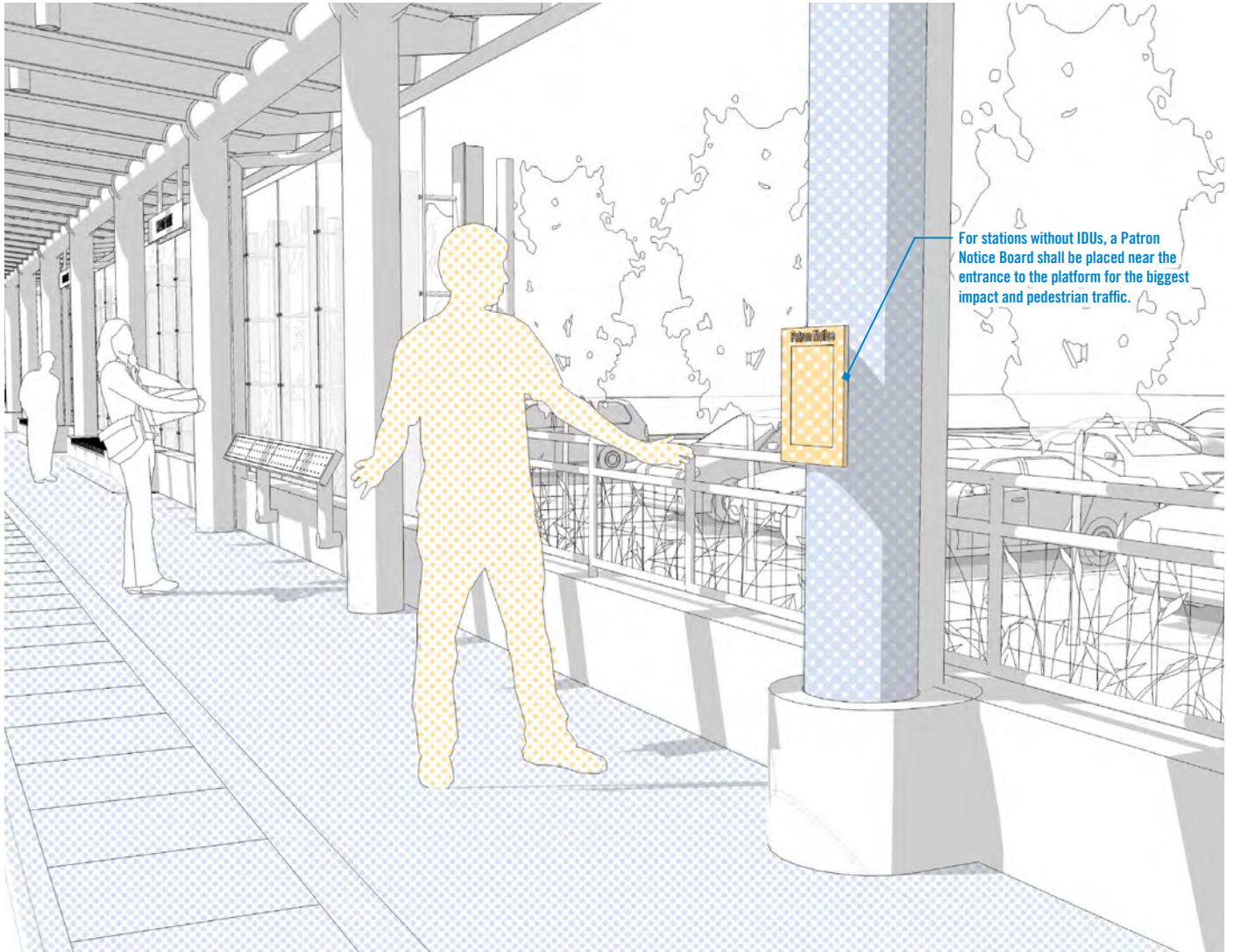

For stations without IDUs, a Patron Notice Board shall be placed near the entrance to the platform for the biggest impact and pedestrian traffic.



Patron Notice Board under covered platform shelter at Longwood Station, Boston



Patron Notice Board integrated into station entry signage at Prospect Park Station, Minneapolis

PUBLIC ADDRESS SYSTEM

The public-address portion of the patron notice system is a series of speakers and screens located throughout the public areas that can provide recorded or real-time messages to the passengers. The goal of this system is to provide public safety and efficient operations information to passengers including people with disabilities.

EXISTING

Types

The existing public-address speakers are mounted in a way to project sound in each direction from the platform. The speakers are round or cylindrical and are mounted high on poles or under canopies in a way to deter vandalism or damage.

Material

The speakers are constructed of a metal body, usually aluminum, and a perforated aluminum screen.

Challenges

The challenges facing the public-address system are maintenance of the system to make sure the speakers announce properly and keeping current with technology.

Opportunities

If PAAC were to replace the system, the opportunity exists to upgrade to a current technology.

REPAIR

Repair any damaged speakers with in-kind new equipment where possible.

REPLACE

Replace any damaged or non-functioning speakers with new speakers that meet the guidelines for new equipment.

NEW

LRT stations should include a public-address system to convey information to people with disabilities in compliance with ADA requirements and for public safety. Speakers should be positioned to be clearly audible, but not readily accessible to the public or potential vandalism. The designer shall provide sufficient dedicated conduit capacity to support a series of speakers located throughout public areas that can carry recorded and real-time announcements at a central location. The public-address systems shall be heard throughout the entire boarding area and will have a volume that exceeds the prevailing ambient sound by at least 15 decibels.

Public Address Systems shall be provided at Category 1 and 2 stations, and any stations which have the infrastructure and high ridership to support the need. For Category 3, 4 and 5 stations, Public Address Systems are optional depending on availability of infrastructure and demand.

SURVEILLANCE CAMERAS

Passengers need to perceive that their environment is secure and openly visible to other users around them, particularly in the evening. It is important to avoid creating blind corners, alcoves, and dark spaces that are uninviting. It is desired that natural surveillance is promoted by providing open and visible lines of sight to station elements and passengers. In addition to natural surveillance, strategically positioned surveillance cameras should be considered under canopies or attached to vertical support poles. Cameras should be located above 9 feet minimum and supported by lighting levels that make the cameras most effective in areas of surveillance.

EXISTING

The LRT system does support existing surveillance cameras, which are positioned to view the site entrances and platform areas, at many of the stations.

REAL-TIME ARRIVAL INFORMATION

Real-time arrival is part of the overall transit information system that serves to provide clear and legible navigation for passengers. Alerting riders about schedule and real-time arrival information reduces uncertainty and improves passenger satisfaction and experience.

EXISTING

The current real-time arrival screens are located perpendicular to the platform edge and mounted under canopies.

NEW

Location & Orientation

Real-time arrival can be in different areas to provide the greatest visibility to the passengers and to create interest and options for varying site conditions.

Canopy-mounted or vertically-mounted overhead Real-Time Arrival Information displays shall be provided at stations with the structure and infrastructure. These displays shall be mounted perpendicular to the tracks, as to be seen by patrons waiting on platforms.

Number of Real-Time Arrival Information

Station Category	# of Displays per Track	
	Minimum	
Category 1	3	
Category 2	2	
Category 3	2	
Category 4	1 / varies	
Category 5	1 / varies	

For Category 1 Stations, provide at least three canopy-mounted Real-Time Arrival Information displays per track, evenly spaced along the platform. For Category 2 and Category 3 Stations, provide at least two Real-Time Arrival Information display. Select Category 4 stations which have a canopy or structure should be provided with at least one Real-Time Arrival Information display. Category 5 stations, if feasible, should be provided with one Real-Time Arrival Information display.

The Real-Time Arrival Information can also be considered as part of IDU case as a separate panel located at key information gathering areas for passengers, and when people are waiting for the vehicle on the platform. Real-time arrival information should be placed at each station. It must be equipped with the infrastructure and in a predictable location, such as overhead or at eye-level.

Accessibility

In conjunction with information panels, audible announcements matching real-time arrival display boards must be provided for visually impaired passengers.



For high investment stations, Real-Time Arrival Information displays shall be vertically-mounted, parallel to the tracks, near waiting areas. Adelaide, Australia

TECHNOLOGY INTEGRATION

As new lifestyle technologies evolve, transit agencies should integrate them into their stations and infrastructure. As PAAC strives to increase its ridership while advancing its brand as an enjoyable mode of transportation, investments should be made into technological amenities that provide transit riders with infrastructure that makes waiting times seem shorter and more exciting.

Some of these amenities include:

- Personal device charging stations.
- WiFi Hotspots.
- Dynamic advertising.
- Interactive wayfinding and transit schedules.

Other transit agencies have partnered with technology or

advertising companies that provide, build, and maintain the technology infrastructure and accompanying structures, in return for advertising rights. This arrangement or relationship is ideal, and should be pursued if the opportunity is presented.

Regardless of arrangement, the integrated technology installed in the future should be aesthetically, stylistically, and visually similar to existing structures at stations. If possible, integrate these technologies into existing Information Display Units, where power and infrastructure is provided. Placement of new integrated technology structures should follow the guidelines for IDUs, and be placed where it does not obstruct the accessible route for pedestrians.



WiFi kiosks with integrated device charger and touch-screen internet access.
Product by Intersection in New York City



Interactive wayfinding and transit schedule kiosk with integrated device charger on platform. Product by Intersection in New York City

4.



APPENDIX



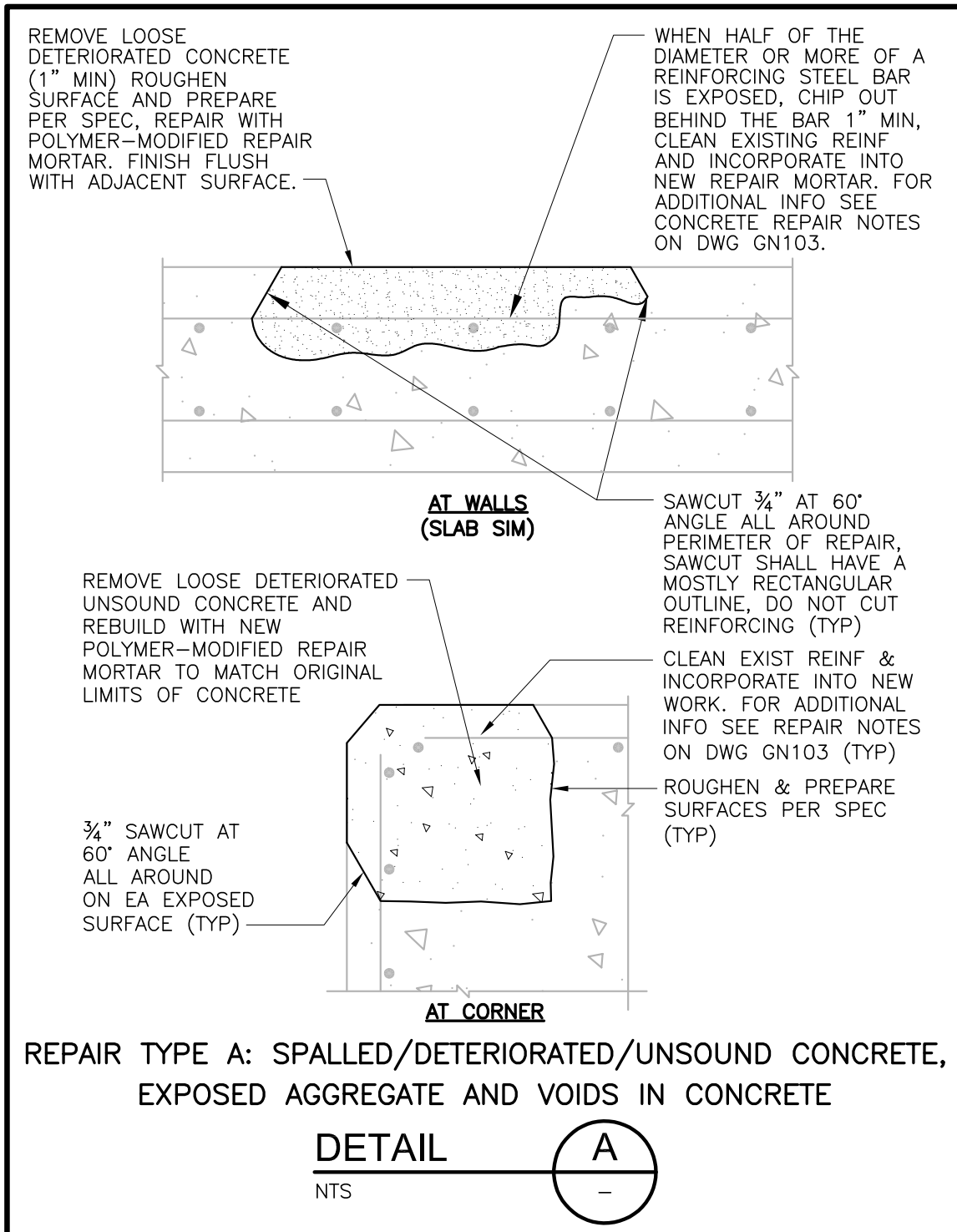

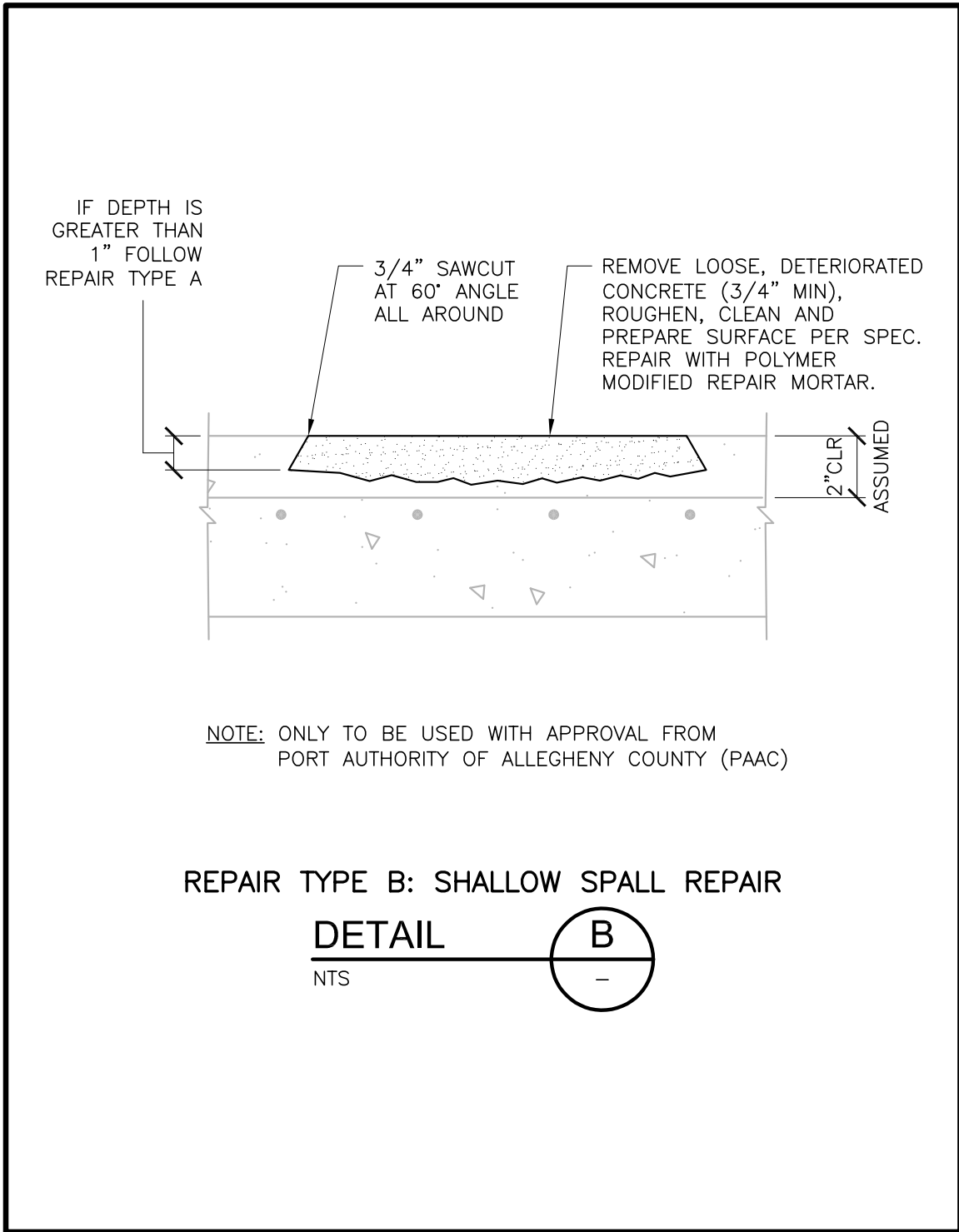

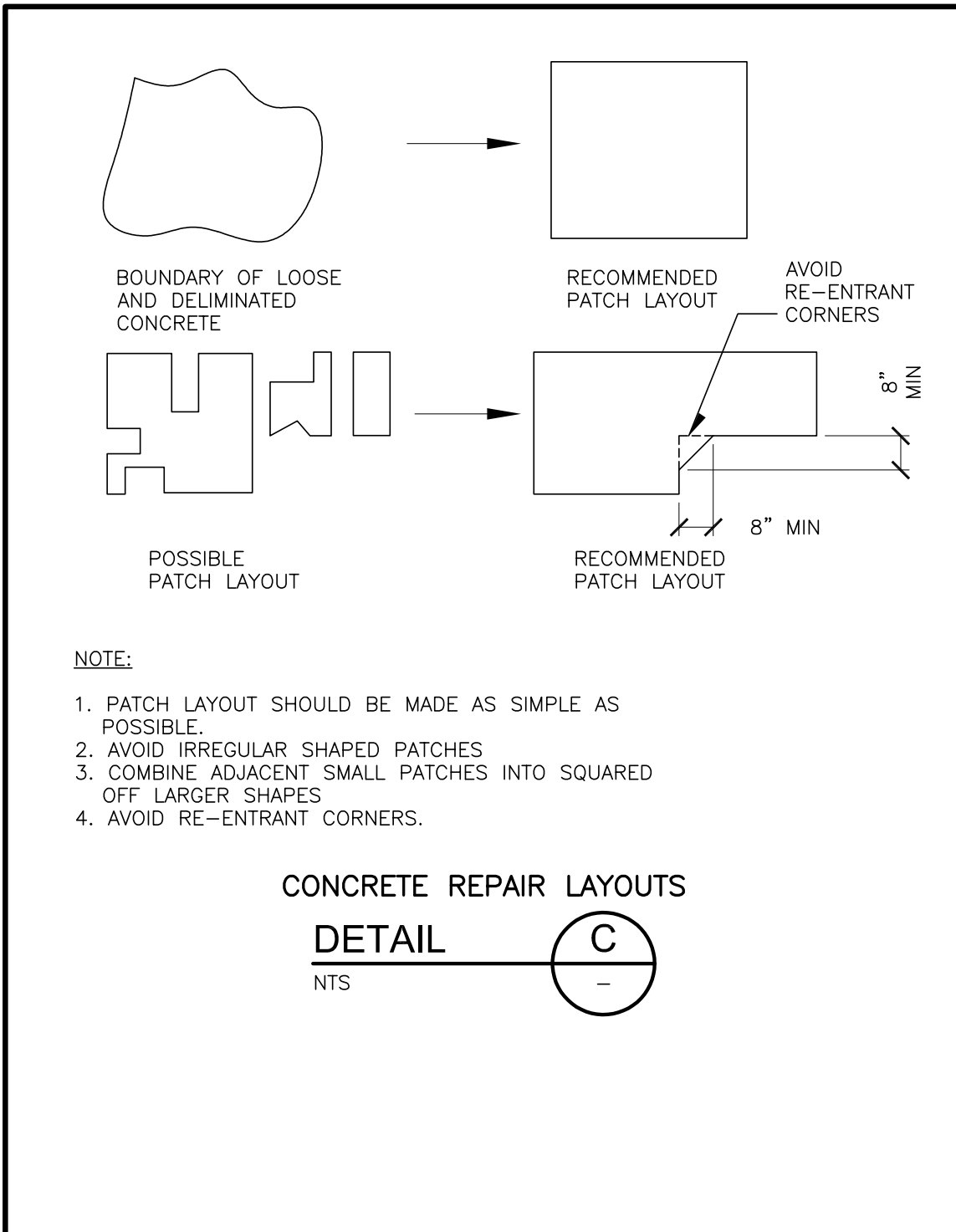

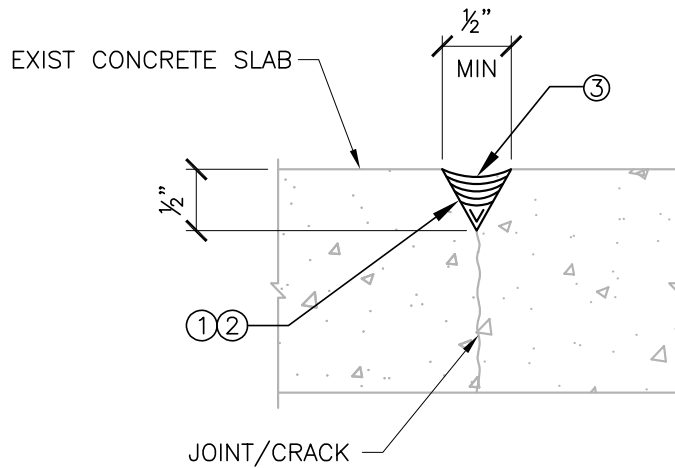

NOTE: ONLY TO BE USED WITH APPROVAL FROM
PORT AUTHORITY OF ALLEGHENY COUNTY (PAAC)

REPAIR TYPE M: EPOXY JOINT/CRACK REPAIR

DETAIL

NTS

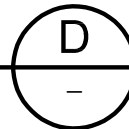

KEYED NOTES:

- ① GRIND EDGES OF JOINT/CRACK TO FORM V-SHAPED GROOVE ON INTERIOR FACE OF SURFACE.
- ② CLEAN SURFACE OF V-SHAPED JOINT TO REMOVE DIRT/DUST. ADD FINE SAND TO V-SHAPED GROOVE PRIOR TO INSTALLATION.
- ③ INSTALL EPOXY CRACK SEALER BY GRAVITY FEED PER MANUFACTURER'S REQUIREMENTS.

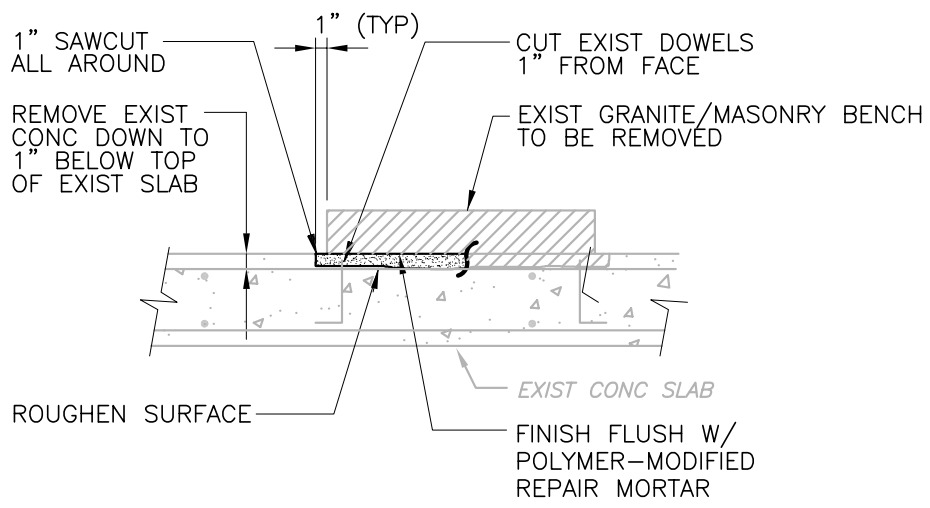

CONCRETE/MASONRY BENCH REMOVAL



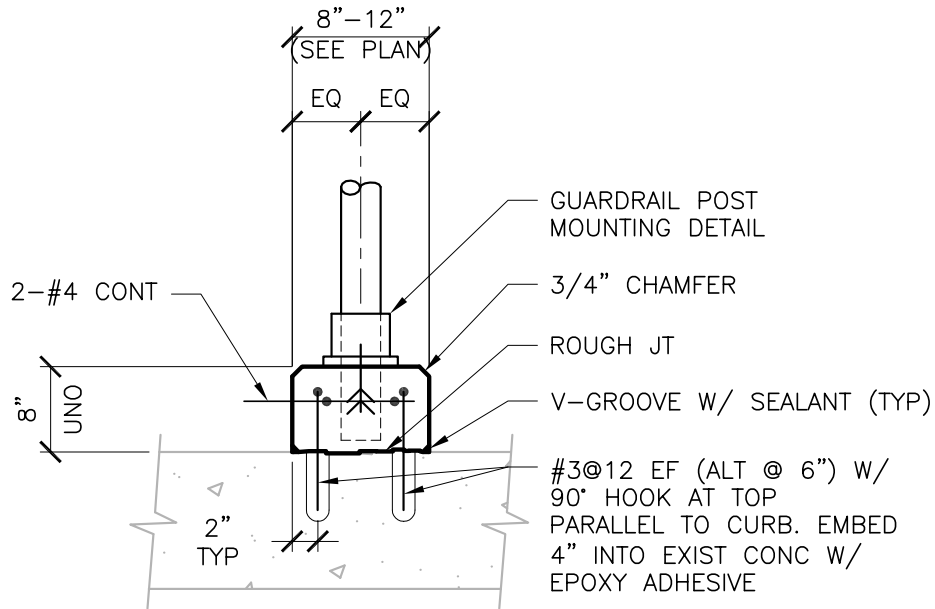

GUARDRAIL MOUNTED TO CONCRETE CURB

DETAIL

NTS

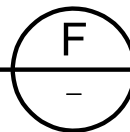

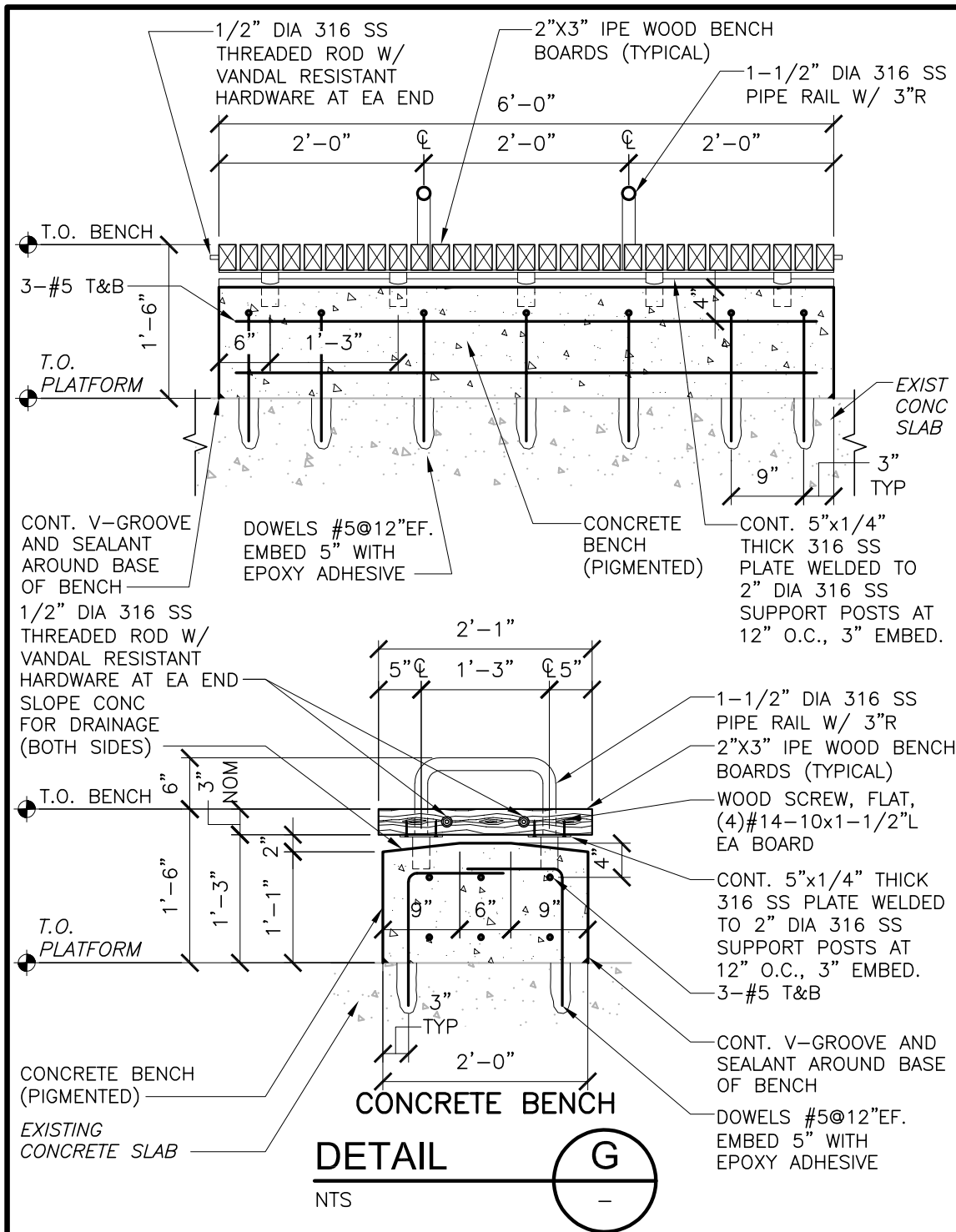

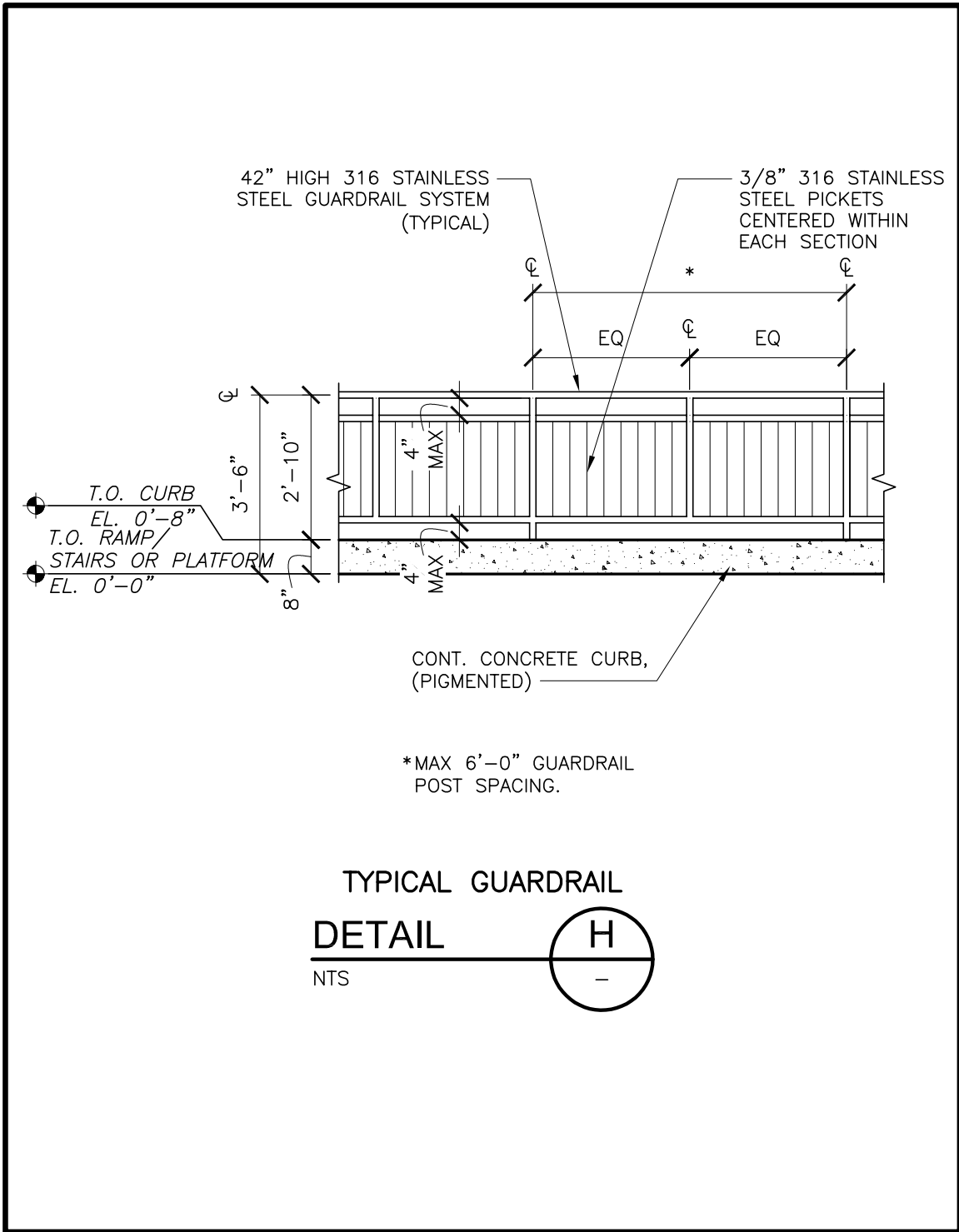

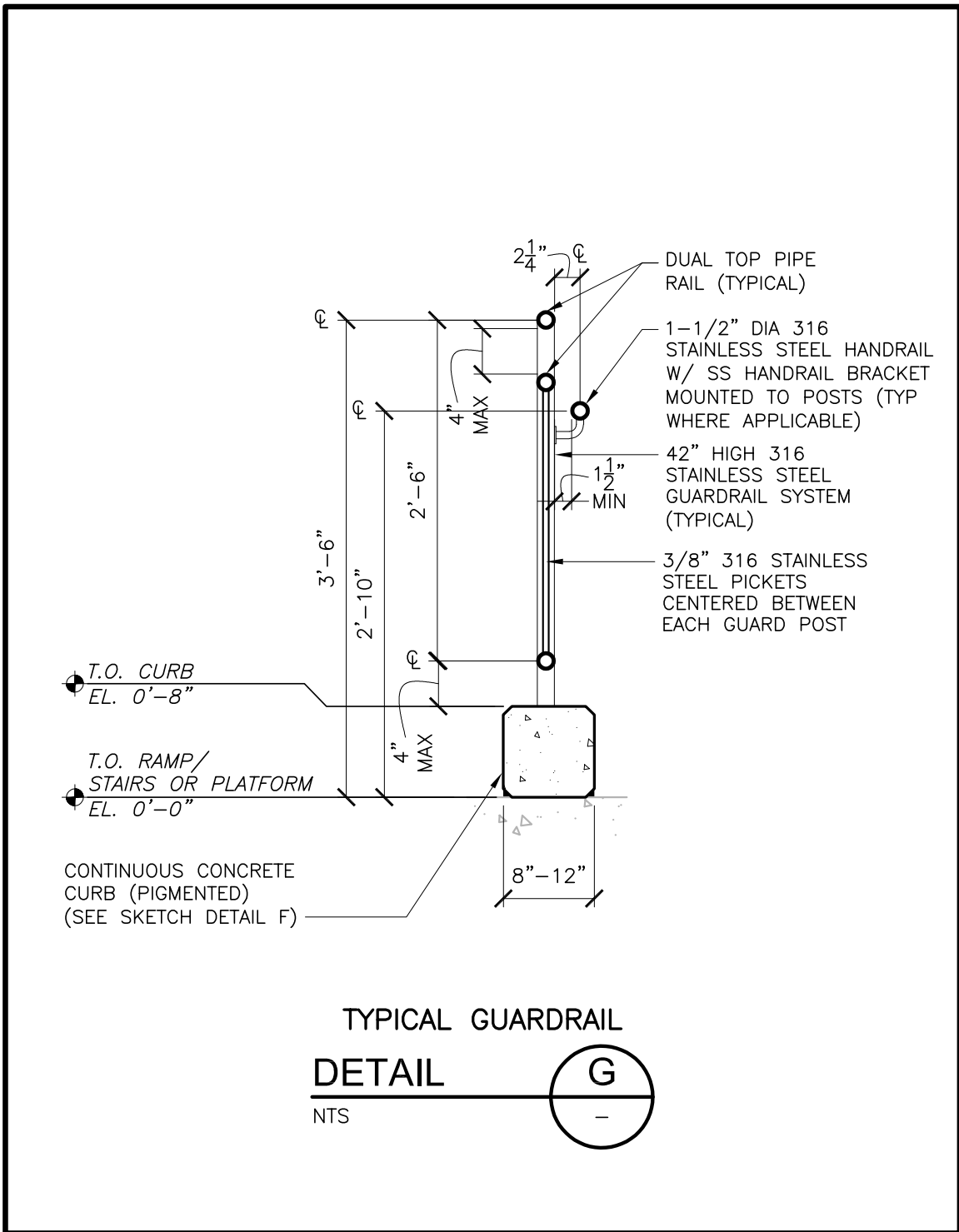



COLOR APPLICATION

Curved Canopy Type



COLOR APPLICATION

Flat Canopy Type



COLOR APPLICATION

Sloped Canopy Type

ORGANIZATION EXAMPLE : STATION CANOPY TYPE-BASED

Each station can be organized according to their canopy type, where stations within these canopy types have similar aesthetic, architectural, and logistical characteristics.











For stations which are unique or do not have similar stations to it in the system, guidelines for new and ideal stations should be applied.

The station with similar canopies tend to have similarly sized platform heights, platform lengths, and contextual settings.

Flashcards, which focus on aesthetic maintenance issues, can detail the uniform color palette and elements common to each station canopy type.

FLASHCARD

1.00 STATION CANOPY TYPE

<p>1.01 STAGE II High Long Platform Category #3</p>  <p>Bojangles Boh Air Denise Kilmer Library McHenry Memorial Hall South Bank Willow</p>	<p>1.05 FLAT BUS SHELTER Low Platform Category #5</p>  <p>Caswell</p>	<p>1.09 UNIQUE High Long Platform</p>  <p>Castle Shannon First Ave. Polomac South Hills Village Station Square Washington Junction</p>
<p>1.02 CURVE High Long/Short Platform Category #2 + #4</p>  <p>Lyle Overbrook Junction</p>	<p>1.06 AT-GRADE Low Platform Category #5</p>  <p>Belasco Hempshire Shiras</p>	<p>1.10 NONE Low Platform Category #5</p>  <p>Sandy Creek Smith Rd.</p>
<p>1.03 ANGLE Low Platform Category #5</p>  <p>Arlington Bethel Village Dorchester Highland Palm Gardens Pensacola Piquette St. Annes Stevenson Woodfield</p>	<p>1.07 PITCHED High Long Platform Category #1 + #2</p>  <p>Fallowfield S. Hills Junction S. Hills Village</p>	
<p>1.04 ROUND BUS SHELTER Low Platform Category #5</p>  <p>Bojangles Daem Wilkens Kings School Rd. Logan Rd. Moss Monroe Seash South Park Rd. W. Library</p>	<p>1.08 FLAT High Long Platform Category #2</p>  <p>Dormant Mt. Lebanon</p>	

FLASHCARD BASE

- The base organization of the following set of flashcards are based on Station Canopy Type, based under the 1.00 set.
- Additionally, there are flashcards based on Station Elements, based under the 2.00 set.
- As PAAC's system evolves, additional flashcards based on an organizational system as needed can be developed and added as the 3.00 set, etc.

TYPICAL STATION PHOTO

- Image of a station that is the most typical of the station canopy type.

CANOPY TYPE DESCRIPTION

- The name of the station canopy type generally refers to the shape or type of canopy.
- Describe the Category of the typical station of this canopy type (found on page XXX of guidelines)
- List the stations which fall into this canopy type category.

FLASHCARD EXAMPLE : STATION CANOPY TYPE-BASED

Each station canopy type flashcard contains the maintenance and some replacement information for aesthetic applications at a station.

The flashcard is envisioned to be used in-house, mainly by maintenance staff of the PAAC.

It is a quick reference, meant to be used on-site, to help staff make informed decisions. Staff should first reference the Guidelines Document for complete standards on selection, application,

and installation of station elements.

Flashcards focus mainly on the aesthetics of the station canopy type, specifically color palette and elements placement. However, every station has different conditions and context; coordinate efforts amongst departments to ensure visual uniformity and up-to-date quality products.

FLASHCARD

1.02 STATION CANOPY : CURVE

STATIONS

High Long/Short Platform + Category #2 + #4

These stations have a short structure with a distinctive blue, curved canopy with framed windscreen and concrete base. The structure has integrated electricity and wiring that serves the integrated lighting, real-time display unit, PA system, and emergency call boxes into the structure of the canopy.

Lytle
Overbrook Junction

COLOR

PMS 300 C CMYK 100-50-0-0	Light Blue PMS 292 C CMYK 55-14-0-0	Black PMS Black C CMYK 0-0-0-100
Application: - Canopy Metal Work - Mesh Guardrail - Panels	Application: - Canopy Metal Work - Mesh Guardrail - Panels	Application: - Canopy Metal Work - Mesh Guardrail - Panels
Grey PMS XXX C CMYK 0-0-0-70	Light Grey PMS XXX C CMYK 0-0-0-30	
Application: - Canopy Metal Work - Mesh Guardrail - Panels	Application: - Canopy Metal Work - Mesh Guardrail - Panels	

ELEMENTS

Elements for Curve
Station Canopy

Element ID	Required	High Priority / Special Note	Low Priority	Special Installation Instructions	Guidelines Pg.
01. Wheelchair Car Stair	•			See manufacturer's installation specifications.	
02. Suit Storage	•			Place at ends of platform, do not block accessible routes.	
03. Seating	•			Do not block accessible routes, place under canopy whenever possible.	
04. Luggage Bar	•			For narrow platforms less than 6' deep.	
05. Ticket & Recycling Machines	•			Locate adjacent to seating element.	
06. Ticket Vending Machines	•			Place on platform or near entrance to platform.	
07. Information Display Units	•			Place near seating and waiting areas on platform, out of the path of travel.	
08. Wayfinding	•			Do not block accessible routes. Orient with the front transfer panel parallel to the path.	
09. Public Address System	•			Place on platform or near entrance to platform.	
10. Public Address System	•			Speakers should be integrated into the canopy or on lampposts.	
11. Supplemental Closures	•			Coordinate with PAAC security. Place in back to see areas of danger on platform.	
12. Real Time Arrival Information	•			Place under canopy, near the center of the platform, perpendicular to tracks.	

FLASHCARD BASE & TYPE

- The title of the flashcard describes what is the base organization of the flashcard, and which type. In this example, the base organization is by Station Canopy, and the type is Curve.
- The numbering system tells you that this is the second type in the first base organization.

STATIONS COLUMN

- Image of a station that is the most typical of the station canopy type.
- Written description of the main characteristics of that station canopy type.
- List the stations with this station canopy type.

COLOR

- Show the color palette, ### and general application in that station canopy type.

ELEMENTS MATRIX

- Lists the elements which may be found at that station canopy type.
- Mark Required, High Priority, and Low Priority for each element.
- Note any special installation instructions, placement / orientation considerations.
- Reference where in the guidelines document more detailed information can be found.

ORGANIZATION EXAMPLE : STATION ELEMENTS-BASED

Certain elements are common amongst all stations. To avoid confusion and maintain visual uniformity and operations efficiency, these flashcards note the type and placement of elements at stations.

These elements were selected because they tend to be common amongst most stations, yet currently vary widely by application, type, or placement.

Each element has different applications and selections criteria.

Therefore, each element flashcard will have a different format.

Elements-based flashcards can be expanded as more standards are confirmed or developed by the PAAC.

For stations which are unique or do not have similar stations to it in the system, guidelines for new and ideal stations should be applied.

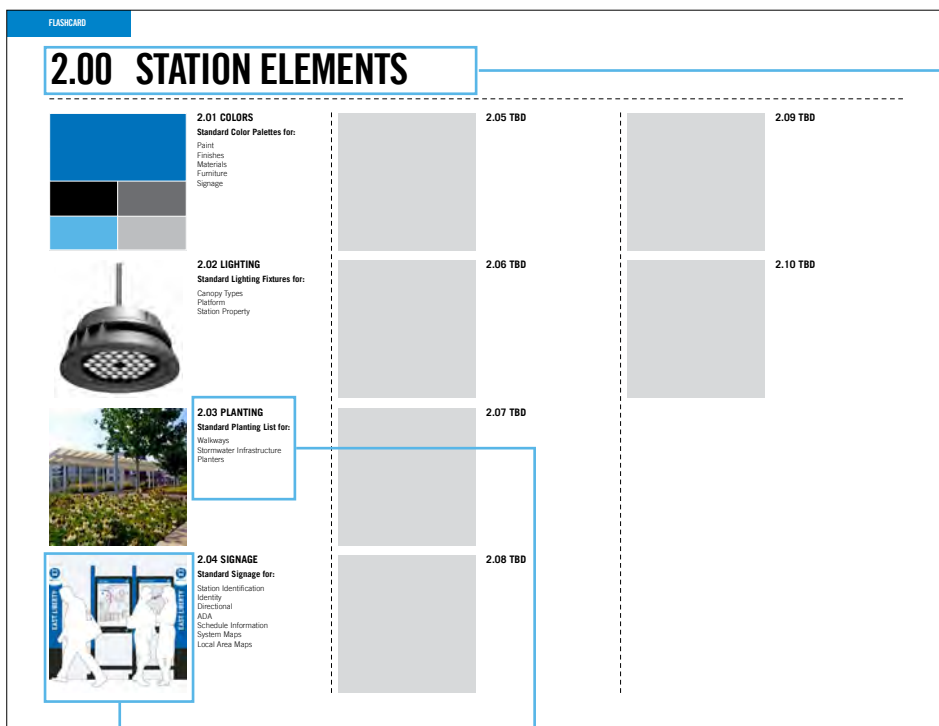

FLASHCARD BASE

- The base organization of the following set of flashcards are based on Station Elements, based under the 2.00 set.
- Additionally, there are flashcards based on Station Canopy Type, based under the 1.00 set.
- As PAAC's system evolves, additional flashcards based on an organizational system as needed can be developed and added as the 3.00 set, etc.

STATION ELEMENT PHOTO

- Image of the typical station element.

STATION ELEMENT DESCRIPTION

- The name of the element which is common among the whole PAAC system, and should be uniformly applied at every station.

FLASHCARD EXAMPLE : STATION ELEMENTS-BASED

Each station element flashcard will be different for each element. But generally, the information should address the placement, product, type, and installation notes.

The flashcard is envisioned to be used in-house, mainly by maintenance staff of the PAAC.

It is a quick reference, meant to be used on-site, to help staff make informed decisions. Staff should first reference the Guidelines Document for complete standards on selection, application,

and installation of station elements.

Flashcards focus mainly on the aesthetics of the station canopy type, specifically color palette and elements placement. However, every station has different conditions and context; coordinate efforts amongst departments to ensure visual uniformity and up-to-date quality products.

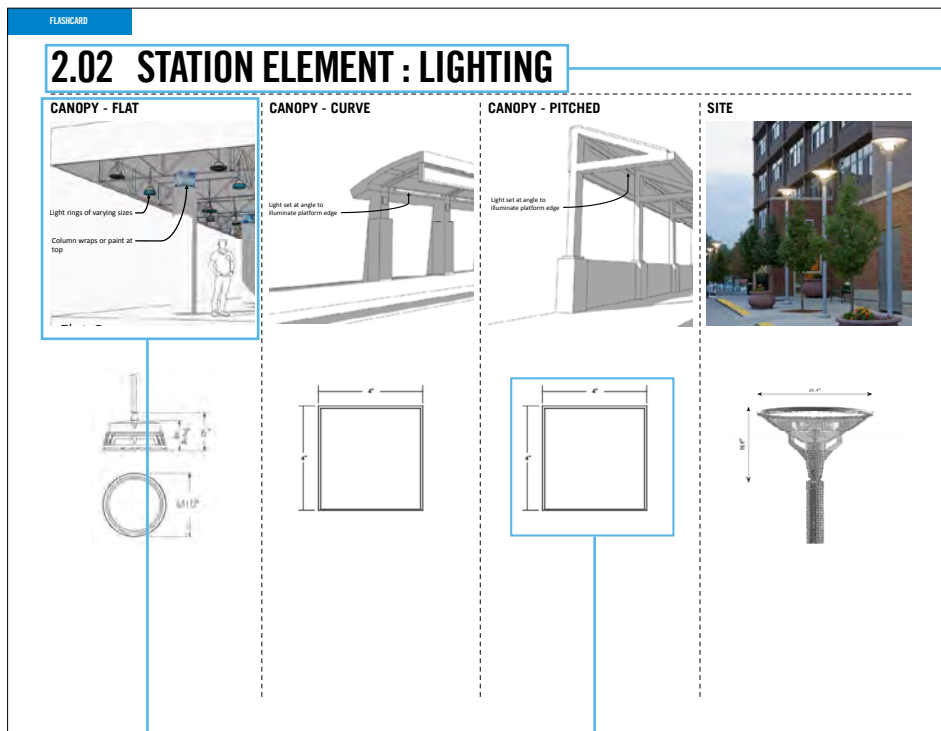

FLASHCARD BASE & TYPE

- The title of the flashcard describes what is the base organization of the flashcard, and which type. In this example, the base organization is by Station Canopy, and the type is Curve.
- The numbering system tells you that this is the second type in the first base organization.

ELEMENT PLACEMENT

- Diagram of how to place or orient the element.
- Note any special installation considerations, ie: power supply, access requirement, etc.

PRODUCT SPECIFICATIONS

- Show any specific product dimensions or considerations.
- Note the product / manufacturer name if known.
- Note specific colors or types.

IMAGE INDEX & CREDITS

Cover Image	Photo by Port Authority of Allegheny County		Top Right: Photo by Jeremiah Cox
Page 4	Photo by Studio for Spatial Practice		Bottom: Photo by Sound Transit
Page 6	Photos by Studio for Spatial Practice	Page 44	Photo by CDM Smith
Page 7	Top: Photo by Mass Transit Magazine	Page 47	Photo by Studio for Spatial Practice
	Middle / Bottom: Photos by CDM Smith	Page 50	Photo by Jeremiah Cox
Page 10	Photo by Port Authority of Allegheny County	Page 51	Photo by ProRail
Page 13	Photos by CDM Smith	Page 52	Top: Photo by Alexia Hinton / Metro
Page 15-19	Photos by CDM Smith		Bottom: Photo by Omega Industries Inc.
Page 20	Photo by CDM Smith	Page 53	Photo by Godofredo A. Vasquez / Houston Chronicle
Page 22	Top: Photos by Studio for Spatial Practice	Page 54	Photo by CDM Smith
	Bottom: Photo by marketsquarepgh.blogspot	Page 55	Photos by CDM Smith
Page 24	Top: Photo by Massery Photography / GBBN	Page 56	Top Left: Photo by Craig Kuhner / Sasaki
	Bottom: Photo by Studio for Spatial Practice		Top Right: Photo by Genesee/Finger Lakes Regional Planning Council
Page 25	Top: Photo by Judy Hedding / TripSavvy		Bottom: Photo by GreenWorks
	Middle: Photo by Jennifer Simonson / MPR News	Page 58	Photo by CDM Smith
	Bottom: Photo By Luke H. Gordon / Flickr	Page 59	Left: Photo by Craig Kuhner / Sasaki
Page 27	Top: Photo by Studio for Spatial Practice		Right: Photo by mrwestside.com
	Middle: Photo by Belarde Company	Page 60	Photo by Forms+Surfaces
	Bottom Left: Photo by Studio for Spatial Practice	Page 63	Top: Photo by snapdujour.blogspot.com
	Bottom Right: Photo by Massery Photography		Middle: Photo by threetreecenter.om
Page 28	Top: Photo by Tom Bonner		Bottom: Photo by
	Bottom: Photo by Liam Henderson	Page 64	Top Left: Photo by Robert Holman
Page 29	Top: Photos by Jeremiah Cox		Top Right: Photo by Studio for Spatial Practice
	Middle: Photo by Studio for Spatial Practice		Middle Left: Photo by Genesee/Finger Lakes Regional Planning Council
	Bottom: Photo by Otak	Lakes	Middle Right: Photo by GreenWorks
Page 30	Top: Photo by Massery Photography		Bottom Left: Photo by fluidworkstudio.wordpress.com
	Bottom: Photo by Studio for Spatial Practice		Bottom Right: Photo by gardenriots.com
Page 31	Top: Photo by Studio for Spatial Practice	Page 67	Top: Photo by Alan Berner / The Seattle Times
	Middle: Photo by GBBN		Middle: Photo by Jeremiah Cox
	Bottom: Photo by Richard Tsong-Taatarii / Star Tribune	Page 68	Bottom: Photo by Office of Public Art
Page 32	Top Left: Photo by Brett Coomer / Houston Chronicle		Left: Photo by CDM Smith
	Top Right: Photo by Massery Photography	Page 69	Right: Photo by Deninno Architects
	Bottom: Photo by Studio for Spatial Practice	Page 71	Photos by Jeremiah Cox
Page 35	Photo by CDM Smith		Top Left: Photo by Washington Metropolitan Area Transit Authority
Page 36	Photos by CDM Smith		
Page 42	Top Left: Photo by Massery Photography		

	Top Right: Photo by bikeparking.com		Bottom Left: Photo by Studio for Spatial Practice
	Bottom Left: Photo by frontporchne.com		
	Bottom Right: Photo by 2mstreet.com	Page 102	Left: Photo by metroduo.wordpress.com
Page 73	Top: Photo by Rebecca Deveraux / 90.5 WESA	Page 105	Right: Photo by Studio for Spatial Practice
	Middle: Photo by Oregon Convention Center	Page 106	Photo by SounderBruce / Flickr
	Bottom: Photo by ARLnow.com		Left: Photo by Studio for Spatial Practice
Page 76	Top: Photo by Sahar Coston-Hardy / Sasaki	Page 109	Right: Photo by Sound Transit
	Bottom: Photo by BriceHouse Inc.	Page 112	Photos by Studio for Spatial Practice
Page 78	Left: Photo by Ben Benschneider/ Brooks + Scarpa	Page 113	Photo by MetroSpec
	Right: Photo by Metrolink	Page 114	Left: Photo by CityBridge
Page 79	Photo by Google		Right: Photo by Intersection
Page 80	Left: Photo by TriMet		Photo by Massery Photography
	Right: Photo by Studio for Spatial Practice		
	Bottom: Photo by Steve Hymon / Metro		
Page 84	Photo by New York City Department of Transportation		
Page 85	Photos by Studio for Spatial Practice		
Page 88	Top: Photo by City of Charlotte		
	Bottom: Photo by Studio for Spatial Practice		
Page 90	Photo by CDM Smith		
Page 91	Photo by Merritt Graphics		
Page 92	Left: Photo by Office of Public Art		
	Right: Photo by Northwest Progressive Institute		
Page 93	Top Left: Photo by Studio for Spatial Practice		
	Top Right: Photo by Santa Clara Valley Transportation Authority		
	Bottom Left: Photo by Metro Transit		
	Bottom Right: Photo by downtownphoenixjournal.com		
Page 94	Left: Photo by Studio for Spatial Practice		
	Right: Photo by SounderBruce / Flickr		
Page 99	Photo by CDM Smith		
Page 100	Left: Photo by Studio for Spatial Practice		
	Right: Photo by Jeremiah Cox		
Page 101	Top left: Photo by Studio for Spatial Practice		
	Top Right: Photo by Jeremiah Cox		
